

COLE COUNTY DEPARTMENT OF PUBLIC WORKS



TANNER BRIDGE ROAD  
SAFETY IMPROVEMENTS PROJECT – PHASE 1

Project No. 2017-601-1

BID DATE: August 30, 2019

BIDDING DOCUMENTS

# TABLE OF CONTENTS

	<b>PAGE NO.</b>
<b>SECTION 1</b>	
Advertisement for Bids	1-1
Notice to Bidders	1-3
<b>SECTION 2</b>	
Instructions to Bidders	2-1
<b>SECTION 3</b>	
Bid Proposal Form	3-1
Anti-Collusion Statement	3-7
Contractor's Affidavit	3-9
<b>SECTION 4</b>	
Construction Contract	4-1
Certificate of Insurance	4-7
Performance and One-Year Guarantee Bond	4-9
<b>SECTION 5</b>	
Current Prevailing Wage Rate	5-1
<b>SECTION 6</b>	
Job Special Provisions	6-1
<b>SECTION 7</b>	
General Special Provisions	7-1
<b>SECTION 8</b>	
Technical Specifications	8-1
<b>SECTION 9</b>	
MoDNR Land Disturbance Permit	9-1
<b>SECTION 10</b>	
Cole County Storm Water Pollution Prevention Plan (SWPPP)	10-1

## ADVERTISEMENT FOR BIDS

### NOTICE TO BIDDERS

SEALED PROPOSALS consisting of:

#### **TANNER BRIDGE ROAD SAFTEY IMPROVEMENTS PROJECT – PHASE 1 PROJECT NO. 2017-601-1**

Located on Tanner Bridge Road in Sec 25 & 36, T44N, R12W in Cole County, Missouri,

WILL be received and opened publicly at the office of Cole County Commission, Courthouse Annex, Room 200, 311 East High Street, Jefferson City, Missouri 65101 at

**9:00 A.M. on Friday, August 30, 2019**

Any and all bids received after the time specified above will be returned unopened.

The proposed work consists of removals, clearing and grubbing, grading, excavating, drainage structures, aggregate base, asphalt paving, pavement striping, rip-rap, turf reinforcement mat, fence work, seeding and mulching, erosion control, and miscellaneous work on Tanner Bridge Road near Jefferson City.

Plans and specifications may be viewed online in the bids section at [www.colecounty.org](http://www.colecounty.org). All contractors wishing to bid on this project shall obtain an official copy of the plans and specifications at the office of the Cole County Department of Public Works, 5055 Monticello Road, Jefferson City, Missouri 65109-9182, (573) 636-3614. A payment of **\$25.00** per set of complete plans and specifications will be charged for printing and is not refundable. All checks or money orders for plans and specifications for shall be made payable to Cole County Road & Bridge Fund.

A Pre-Bid Conference will be held on Thursday, **August 22, 2019, at 9:00 A.M.** at the Cole County Commission Office in the Courthouse Annex Building, Room 200, 311 E. High St., Jefferson City, MO 65101. All bidders are urged to attend.

The Owner reserves the right to reject any and all bids and to waive informalities therein, to determine the lowest and best bid and to approve the bond. E.O.E.

News Tribune: 08/04/19; 08/11/19 and 08/18/19



## **NOTICE TO BIDDERS**

Sealed proposals will be received at the office of the Cole County Commission, Courthouse Annex, Room 200, 311 East High Street, Jefferson City, Missouri, 65101, until **9:00 A.M. on Friday, August 30, 2019**. The bids will be opened and read aloud at the Cole County Commission, Courthouse Annex, Room 200, 311 East High Street at 9:00 A.M. on that same day.

The proposed work consists of removals, clearing and grubbing, grading, excavating, drainage structures, aggregate base, asphalt paving, pavement striping, rip-rap, turf reinforcement mat, fence work, seeding and mulching, erosion control, and miscellaneous work for:

### **TANNER BRIDGE ROAD SAFETY IMPROVEMENTS PROJECT – PHASE 1 PROJECT NO. 2017-601-1**

All equipment, material, and workmanship must be in accordance with the plans, specifications, and contract documents on file with the Director of Cole County Public Works, 5055 Monticello Road, Jefferson City, Missouri 65109.

Plans and specifications may be inspected and are available to bidders at the office of the Director of the Cole County Department of Public Works, 5055 Monticello Road, Jefferson City, Missouri 65109-9182, (573) 636-3614.

#### **Payment for Plans and Specifications**

A payment of **\$25.00** per set of complete plans and specifications will be charged for printing and postage and is not refundable. All checks or money orders for plans and specifications shall be made payable to Cole County Road and Bridge Fund.

All wages paid for work under this contract shall comply with requirements of the prevailing wage law of the State of Missouri, Section 290.210 through 290.340, RSMo. 1986.

A certified check on a solvent bank or a bid bond by a satisfactory surety in an amount to five percent (5%) of the total amount of the bid must accompany each proposal.

A one-year Performance and Guarantee Bond is required.

The County reserves the right to reject any or all bids and to waive informalities therein to determine which is the lowest and best bid and to approve the bond.

COUNTY OF COLE  
Larry J. Benz, P.E.  
Director of Public Works



## **INSTRUCTIONS TO BIDDERS**

### **2-1 Scope of Work**

The proposed work consists of removals, clearing and grubbing, grading, excavating, drainage structures, aggregate base, asphalt paving, pavement striping, rip-rap, turf reinforcement mat, fence work, seeding and mulching, erosion control, and miscellaneous work on Tanner Bridge Road near Jefferson City.

### **2-2 Inspection of Plans, Specifications, and Site of Work**

The bidder is required to examine carefully the site of the proposed work, the proposal, plans, specifications, supplemental specifications, special provisions, and contract forms before submitting a proposal.

### **2-3 Interpretation of Contract Documents**

If the bidder has any questions which arise concerning the true meaning or intent of the Plans, Specifications, or any part thereof, which affect the cost, quality, quantity, or character of the project, he shall request in writing that an interpretation be made and an addendum be issued by the Engineer, which shall then be delivered to all bidders to whom Plans and Specifications have been issued. Failure to have requested an addendum covering any questions affecting the interpretations of the Plans and Specifications shall not relieve the Contractor from delivering the completed project in accordance with the intent of the Plans and Specifications to provide a workable project.

### **2-4 Qualifications of Bidders**

The County of COLE may make such investigations as deemed necessary to determine the ability of the bidder to perform the work and the bidder shall furnish to the County of COLE all such information and data for this purpose as the County of COLE may request. The County of COLE reserves the right to reject any bid if the evidence submitted by the bidder or investigation of such bidder fails to satisfy the County of COLE that such bidder is properly qualified to carry out the obligations of the Contract and to complete the work contemplated therein.

### **2-5 Equivalent Material**

Wherever definite reference is made in these Specifications to the use of any particular material or equipment, it is to be understood that any equivalent material or equipment may be used which will perform adequately the duties imposed by the general design, subject to the approval of the Engineer.

### **2-6 Bid Security**

Each bid must be accompanied by a certified check or bid bond made payable to the County of COLE for five percent (5%) of the amount of the base bid. Bid securities will be returned after award of contract except to the successful bidder.

Should the successful bidder or bidders fail or refuse to execute the bond and the contract required within ten (10) days after he has received Notice of Acceptance of his bid, he shall forfeit to the County of COLE as liquidated damages for such failure or refusal, the security deposited with his bid.

## **2-7 Preparation of Bids**

Bid must be made upon prescribed forms attached at the back of these Specifications. Only sealed bids will be considered, all bids otherwise submitted will be rejected as irregular.

All sales taxes which might lawfully be assessed against the County of COLE are to be paid by the Contractor from the monies obtained in satisfaction of his Contract, it being understood by the bidder that the bid prices submitted shall include the cost of such taxes.

All blank spaces in the bid must be filled in and no change shall be made in the phraseology of the bid or addition to the items mentioned therein. Any conditions, limitation, or provisions attached to bids will render them informal and may be considered cause for their rejection.

## **2-8 Prices**

The price submitted for each item of the work shall include all cost of whatever nature involved in its construction, complete in place, as described in the Specifications.

## **2-9 Addenda**

Addenda may be issued on this project at any time up to 24 hours prior to the bid date and time. Occasionally an addendum may contain information that could affect a contractor's bid. It shall be the responsibility of the contractor to verify if any addenda have been issued prior to submitting their bid. The County assumes no liability if a contractor fails to incorporate addenda into their bid.

## **2-10 Approximate Quantities**

In cases where any part or all of the bidding is to be received on a unit price basis, the quantities stated in the bid will not be used in establishing final payment due the successful Contractor. The quantities stated on which unit prices are so invited are approximate only and each bidder shall make his own estimate from the plans of the quantities required on each item and calculate his unit price bid for each item accordingly. Bids will be compared on the basis of number of units stated in the bid. Such estimated quantities, while made from the best information available, are approximate only. Payment on the Contract will be based on actual number of units installed on the completed work.

## **2-11 Lump Sum Items**

Payment for each lump sum item shall be at the lump sum bid for the item, complete in place, and shall include the costs of all labor, materials, tools, and equipment to construct the item as described herein and to the limits shown on the Plans.

## **2-12 Submission of Bids**

The Bid and the Bid Security guaranteeing the same shall be placed in a sealed opaque envelope and marked **TANNER BRIDGE ROAD SAFETY IMPROVEMENTS PROJECT – PHASE 1, PROJECT NO. 2017-601-1**. The envelope shall be clearly marked with the project name, project number, and the bidder's name and address.

## **2-13 Alternate Bids**

In making the award if alternate bids have been requested, that alternate bid will be used which will be to the best interest of the County of COLE.

## **2-14 Withdrawal of Bids**

If a bidder wishes to withdraw his bid, he may do so before the time fixed for the opening, without prejudice to himself. No bidder may withdraw his bid for a period of ninety (90) days after the scheduled closing time for the receipt of bids.

## **2-15 Right to Reject Bids**

The County of COLE reserves the right to reject any or all bids, to waive any informality in the bids received, or to accept the bid or bids that in its judgment will be for the best interest of the County of COLE.

## **2-16 Award of Contract**

If within ten (10) days after he has received Notice of Acceptance of his bid, the successful bidder or bidders shall refuse or neglect to come to the office of the Director of Public Works and to execute the Contract and to furnish the required Contractor's Bond, properly signed by the Contractor and the Surety or Sureties satisfactory to the County of COLE as hereinafter provided, the bidder or bidders shall be deemed to be in default and shall forfeit the deposit.

## **2-17 Performance Bond**

A Performance Bond in an amount equivalent to one hundred percent (100%) of the Contract price, must be furnished and executed by the successful bidder or bidders, this bond to be in the form contained in this Contract.

The Surety shall be a corporate Surety Company or companies of recognized standing licensed to do business in the State of Missouri and acceptable to the County of COLE.

## **2-18 Indemnification and Insurance**

The Contractor agrees to indemnify and hold harmless the County and the Engineer from all claims and suits for loss of or damage to property, including loss of all judgments recovered therefore, and from all expense in defending said claims, or suits, including court

costs, attorney fees, and other expense caused by any act or omission of the Contractor and/or his subcontractors, their respective agents, servants, or employees.

### Certificate of Insurance

The Contractor shall be required to provide the County of COLE with a "Certificate of Insurance."

### **2-19 Bid Security Returned to Successful Bidder**

Upon the execution of the Contract and approval of Bond, the Bid Security will be returned to the bidder unless the same shall have been presented for collection prior to such time, in which case the amount of the deposit will be refunded by the County of COLE.

### **2-20 Nondiscrimination in Employment**

Contracts for work under this bid will obligate the Contractor and subcontractors not to discriminate in employment practices.

### **2-21 Prevailing Wage Law**

The principal contractor and all subcontractors shall pay not less than the prevailing wage hourly rate for each craft or type of workman required to execute this contract as determined by the Department of Labor and Industrial Relations of Missouri, pursuant to Sections 290.210 through 290.340, RSMo. 1986. (See Determination herewith included in Section 5.)

### **2-22 Guarantee**

The Contractor guarantees that the equipment, materials, and workmanship furnished under this contract will be as specified and will be free from defects for a period of one (1) year from the date of final acceptance. In addition, the equipment furnished by the Contractor shall be guaranteed to be free from defects in design.

Within the guarantee period and upon notification of the Contractor by the County, the Contractor shall promptly make all needed adjustments, repairs, or replacements arising out of defects which, in the judgment of the Engineer, or the County, become necessary during such period.

The cost of all materials, parts, labor, transportation, supervision, special tools, and supplies required for replacement of parts, repair of parts, or correction of abnormalities shall be paid by the Contractor, or by his surety under the terms of the Bond.

The Contractor also extends the terms of this guarantee to cover repaired parts and all replacement parts furnished under the guarantee provisions for a period of one (1) year from the date of installation thereof.

If within ten (10) days after the County gives the Contractor notice of a defect, failure, or abnormality of the work, the Contractor neglects to make, or undertake with due diligence to make, the necessary repairs or adjustments themselves or order the work to be done by

a third party, the costs of the work shall be paid by the Contractor.

In the event of an emergency where, in the judgment of the County, delays would cause serious loss or damage, repairs or adjustments may be made by the County, or a third party chosen by the County, without giving notice to the Contractor, and the cost of the work shall be paid by the Contractor, or by his surety under the terms of the Bond.

### **2-23 Notice to Proceed**

A written notice to begin construction work will be given to the Contractor by the County of Cole immediately after the Contractor has executed the Contract Documents and returned them to the County. The time for completion of the project shall begin to run on the date established in this notice.

### **2-24 Work Schedule**

To insure that the work will proceed continuously through the succeeding operations to its completion with the least possible interference to traffic and inconvenience to the public, the Contractor shall submit for approval a complete schedule of his proposed construction procedure, stating the sequence in which various operations of work are to be performed. The Contractor may not change the work sequence without the prior approval of the Engineer. Additional detailed information can be found in the job special provisions.

### **2-25 Section 292.675 RSMo. Safety Training Requirements**

In 2008 the Missouri General Assembly adopted HB 1549, creating additional requirements affecting public works contracts by requiring all contractors and subcontractors doing work on a project to provide and require their on-site employees to complete a ten (10) hour course in construction safety and health that is approved by the federal Occupational Safety and Health Administration (“OSHA”) or a similar program approved by the Missouri Department of Labor and Industrial Relations, which is at least as stringent as an approved OSHA program; and

#### **The following items will be required in this contract:**

**Section One:** Any contractor for Cole County for purposes of construction of public works and any subcontractor to such contractor shall comply with the provisions of section 292.675, RSMo. and provide a ten-hour OSHA construction safety program for the on-site employees which includes a course in construction safety and health approved by OSHA or a similar program approved by the Missouri Department of Labor and Industrial Relations that is at least as stringent as an approved OSHA program, unless such employees have previously completed the required program.

**Section Two:** All employees who have not previously completed this course must do so within sixty (60) days of beginning work on a Cole County construction project.

**Section Three:** Any employee found on a work site subject to this ordinance without documentation of successfully completing this course shall have twenty (20) days to produce such documentation before being subject to removal from the project.

## **2-26 Excessive Unemployment Law and Restrictive States**

Bidders are hereby notified that the excessive unemployment law is in effect. During times of high unemployment, state law permits the Department's Division of Labor Standards to declare that excessive unemployment is in effect, allowing only workers from certain states to work on the Missouri's public works projects. Public works projects are construction projects funded wholly or partially from public funds, or are projects that benefit the public such as but not limited to schools, parks, fire houses, and government buildings. The excessive unemployment law does not apply to projects funded in part by Federal Funds.

Restrictive states have laws in place restricting Missouri workers to work on their public works projects. Workers from these states are also not allowed to work on Missouri's public works projects.

Only Missouri laborers and laborers from nonrestrictive states are allowed by law to be employed on Missouri's public works projects when the unemployment rate exceeds **5 percent** for two consecutive months. **(See Sections 290.550 through 290.580 RSMo).**

**Restrictive States-** workers from these states are **NOT** allowed to be employed on Missouri public works projects: Alaska, Arizona, California, Colorado, Connecticut, Delaware, District of Columbia, Florida, Idaho, Illinois, Iowa, Maine, Massachusetts, Mississippi, Montana, Nevada, New Jersey, North Dakota, South Dakota, and the U.S. Virgin Islands, West Virginia and Wyoming.

**Non-Restrictive States-** workers from these states are allowed to be employed on Missouri public works projects: Alabama, Arkansas, Georgia, Hawaii, Indiana, Kansas, Kentucky, Louisiana, Maryland, Michigan, Minnesota, Nebraska, New Hampshire, New Mexico, New York, North Carolina, Ohio, Oklahoma, Oregon, Pennsylvania, Rhode Island, South Carolina, Tennessee, Texas, Utah, Vermont, Virginia, Washington and Wisconsin.

## **2-27 Contract Time**

This contract shall be a completion date contract. The contract shall be completed by no later than **November 22, 2019**.

## **2-28 Liquidated Damages / Liquidated Savings**

Liquidated damages shall be assessed if the project is not completed by the completion date in accordance with the provisions of the contract. The contractor may receive an incentive payment (liquidated savings) for completing the project early.

All information pertaining to the liquidated damages and liquidated savings can be found in the Job Special Provisions.

## **2-29 Pre-Construction Meeting**

A pre-construction meeting will be scheduled before construction begins. The contractor's project manager and foreman shall be required to attend.

**PROPOSAL FORM**

**COUNTY OF COLE, MISSOURI**

**TANNER BRIDGE ROAD  
SAFETY IMPROVEMENTS PROJECT – PHASE 1  
PROJECT NO. 2017-601-1**

Name of Bidder: \_\_\_\_\_

Address of Bidder: \_\_\_\_\_

To: Cole County Department of Public Works  
5055 Monticello Road  
Jefferson City, MO 65109

**THE UNDERSIGNED BIDDER**, having examined the Plans, Specifications, Regulations of the Contract, Special Conditions and other proposed Contract Documents, and all addenda thereto; and being acquainted with and fully understanding (a) the extent and character of the work covered by this Proposal; (b) the location, arrangement, and specified requirements for the proposed work; (c) the location, character, and condition of existing streets, roads, highways, railroads, pavement, surfacing, walks, driveways, curbs, gutters, trees, sewers, utilities, drainage courses and structures, and other installation, both surface and underground which may affect or be affected by the proposed work; (d) the nature and extent of the excavations to be made, and the type, character, and general condition of materials to be excavated; (e) the necessary handling and re-handling of excavated materials; (f) the location and extent of necessary or probable dewatering requirements; (g) storm and flood water; (h) local conditions relative to labor, transportation, hauling, and rail delivery facilities; and (i) all other factors and conditions affecting or which may be affected by the work.

**HEREBY PROPOSED** to furnish all required materials, supplies, equipment, tools, and plant; to perform all necessary labor and supervision; and to construct, install, erect, and complete all work stipulated in, required by, and in accordance with the proposed Contract Documents and the drawings, Specifications, and other documents referred to therein (as altered, amended, or modified by addenda), in the manner and time prescribed and that he will accept in full payment sums determined by applying to the quantities of the following items, the following unit prices and/or any lump sum payments provided, plus or minus any special payments and adjustments provided in the Specifications and he understands that the estimated quantities herein given are not guaranteed to be the exact or total quantities required for the completion of the work shown on the drawings and described in the Specifications, and that increases or decreases may be made over or under the Contract estimated quantities to provide for needs that are determined during progress of the work and that prices bid shall apply to such increased or decreased quantities as follows:

## ITEMIZED PROPOSAL

Item No.	Item Description	Unit	Quantity	\$ Unit Price	\$ Amount
1	Removal of Improvements	LS	1		
2	Earthwork	LS	1		
3	Class 3 Excavation in Rock	CY	175.0		
4	4" Type 5 Aggregate Base	SY	3,985.3		
5	4" Type 1 Aggregate Base	SY	361.4		
6	4" of 2" Aggregate Base	SY	363.7		
7	8" Aggregate Shoulders	SY	481.7		
8	2" Bituminous Pavement	SY	2,892.8		
9	6" Bituminous Base	SY	2,973.4		
10	Variable Depth Bituminous Pavement	SY	57.8		
11	6" Asphalt Approach	SY	81.3		
12	6" Asphalt Drive	SY	170.1		
13	Coldmilling Bituminous Pavement	SY	46.6		
14	Four Strand Barbed Wire Fence	LF	1,865.0		
15	14.00' Tubular Steel Gate	EA	2.0		
16	Replace Vinyl Fence	LF	30.0		
17	6" Concrete Drive	SY	137.6		
18	Relocate 8" PVC Water Main	LF	621.0		
19	Rock Ditch Liner	CY	45.6		
20	Traffic Control	LS	1		
21	Mobilization	LS	1		
22	Preformed Marking Tape, 4" Solid Yellow	LF	212.0		
23	Preformed Marking Tape, 24" Yellow Hatch	LF	38.0		
24	Preformed Marking Tape, 24" White Stop Bar	LF	11.0		
25	Acrylic Waterborne Paint, 4" Solid White	LF	4,147.0		
26	Acrylic Waterborne Paint, 4" Solid Yellow	LF	2,123.0		
27	15" Aluminized Corrugated Metal Pipe (14 Ga)	LF	43.8		
28	30" Class III Reinforced Concrete Pipe	LF	66.0		
29	15" Aluminized F.E.S.	EA	4		
30	30" Reinforced Concrete Pipe F.E.S.	EA	2		
31	Seeding, Fertilizing and Mulch	AC	3.07		
32	Temporary Seeding and Mulch	AC	0.31		
33	Erosion Control	LS	1		
34	Clearing and Grubbing - Carrender Property	AC	1.07		
35	Clearing and Grubbing	AC	0.21		
36	P300 Turf Reinforcement Mat	SY	1,295.3		
<b>TOTAL BASE BID:</b>					

BIDDER recognizes and acknowledges the receipt of the following Addenda:

<u>DATE</u>	<u>Addendum Number</u>	<u>DATE</u>	<u>Addendum Number</u>
-------------	------------------------	-------------	------------------------

---

---

If the Bidder intends to use any subcontractor in the course of the construction, he shall list them. (If necessary, attach additional pages to list all subcontractors.)

<u>Company Name</u>	<u>Address</u>	<u>City, State, Zip</u>	<u>Work To Be Performed</u>	<u>% of Bid</u>
---------------------	----------------	-------------------------	-----------------------------	-----------------

---

---

---

---

---

---

---

---

---

---

**TIME OF COMPLETION:**

The undersigned hereby agrees to complete the project by no later than **November 22, 2019**, subject to the stipulations of the regulations of the Contract and the Special Conditions.

It is understood that the specifications governing the construction of the work contemplated are those known and designated as the "Missouri Highway & Transportation Commission Standard Specifications for Highway Construction, 2018" approved by the Missouri Highways & Transportation Commission, together with the special provisions, job and general, if any attached to this proposal.

It is understood and agreed that if this Proposal is accepted, the prices quoted above include all applicable state taxes and that said taxes shall be paid by the Contractor.

The undersigned, as Bidder, hereby declares that the only persons or firms interested in the Proposal as principal or principals is or are named herein and that no other persons or firms than herein mentioned have any interest in this Proposal or in the Contract to be entered into; and this Proposal is made without connection with any other person, company, or parties making a bid or proposal; and that it is in all respects fair and in good faith, without collusion or fraud.

The undersigned agrees that the accompanying bid deposit shall become the property of the County should he fail or refuse to execute the Contract or furnish Bond as called for in the specifications within the time provided.

If written notice of the acceptance of this bid is mailed, telegraphed, or delivered to the undersigned within ninety (90) days after the date of opening of bids, or any time thereafter before this bid is withdrawn, the undersigned will, within ten (10) days after the date of such mailing, telegraphing, or delivering of such notice, execute and deliver a Contract in the form of Contract attached.

The undersigned hereby designates as his office to which such notice of acceptance may be mailed, telegraphed, or delivered:

_____	_____	_____	_____
Contact Person	Company Name	Mailing Address	City, State & Zip Code

It is understood and agreed that this bid may be withdrawn at any time prior to the scheduled time for the opening of bids or any authorized postponement thereof.

Attached hereto is a Bid Bond for the sum of \_\_\_\_\_

\_\_\_\_\_  
\_\_\_\_\_  
\_\_\_\_\_ (\$ \_\_\_\_\_)  
Dollars (cashier's check), made payable to the County of COLE.

**SIGNATURE AND IDENTITY OF BIDDER**

The undersigned states that the correct LEGAL NAME and ADDRESS of (1) the individual bidder, (2) each partner or joint venturer (whether individuals or corporation, and whether doing business under a fictitious name), or (3) the corporation (with the state in which it is incorporated) are shown below; and that (if not signing with the intention of binding himself to become the responsible and sole contractor) he is the agent of, and duly authorized in writing to sign for the Bidder or Bidders; and that he is signing and executing this (as indicated in the proper spaces below) as the proposal of

---

**AN INDIVIDUAL:**

\_\_\_\_\_  
Name of Individual

\_\_\_\_\_  
Residence Street Address

\_\_\_\_\_  
Social Security Number

\_\_\_\_\_  
City, State & Zip Code

\_\_\_\_\_  
Firm Name, If Any

\_\_\_\_\_  
Business Address

\_\_\_\_\_  
Business Telephone Number

\_\_\_\_\_  
City, State & Zip Code

\_\_\_\_\_  
Signature

\_\_\_\_\_  
Date

---

**A PARTNERSHIP:**

\_\_\_\_\_  
Name of Partnership

(State Names & Addresses of All Partners)

\_\_\_\_\_  
Partner

\_\_\_\_\_  
Residence Address

\_\_\_\_\_  
Partner

\_\_\_\_\_  
Residence Address

\_\_\_\_\_  
Business Address

\_\_\_\_\_  
City, State & Zip Code

\_\_\_\_\_  
Business Telephone Number

\_\_\_\_\_  
Signature of At Least One Partner

\_\_\_\_\_  
Date

**A CORPORATION:**

\_\_\_\_\_  
Name of Corporation

Incorporated under the laws of the State  
of \_\_\_\_\_

\_\_\_\_\_  
Name and Title of Officer

Corporate License No. \_\_\_\_\_  
(If a corporation organized in state other  
than Missouri, attach Certificate of \_\_\_\_\_  
Authority to do business in the State of  
Missouri.)

\_\_\_\_\_  
Business Telephone Number

\_\_\_\_\_  
Business Address

\_\_\_\_\_  
City, State & Zip Code

\_\_\_\_\_  
Signature of Officer

\_\_\_\_\_  
Date

ATTEST:

\_\_\_\_\_  
Signature of Secretary (SEAL)

\_\_\_\_\_  
Date









## CONSTRUCTION CONTRACT

**THIS CONTRACT**, made and entered into this \_\_\_\_\_ day of \_\_\_\_\_, 2019, by and between **[INSERT CONTRACTOR'S NAME]**, hereinafter called "Contractor," and the **County of Cole, Missouri**, hereinafter called "County."

**WITNESSETH:** That Whereas, the Contractor has become the lowest responsible bidder for furnishing the supervision, labor, tools, equipment, materials, and supplies and for constructing the following County improvements:

### **TANNER BRIDGE ROAD SAFETY IMPROVEMENTS PROJECT – PHASE 1 PROJECT NO. 2019-601-1**

**NOW, THEREFORE**, the parties to this contract agree to the following:

**1. Manner and Time for Completion** The Contractor agrees with the County to furnish all supervision, labor, tools, equipment, materials, and supplies; to perform all necessary labor and supervision; and to construct, install, erect and complete all work stipulated in, required by and in accordance with the contract documents and drawings, specifications and other documents referred therein (as altered, amended or modified by addenda) and with any applicable County regulations and state and federal laws, within ten (10) working days from the date Contractor is ordered to proceed, which order shall be issued by the Director of Public Works in accordance with the contract documents.

**2. Prevailing Wages** All labor utilized in the construction of the aforementioned improvements shall be paid a wage of no less than the "prevailing hourly rate of wages" for work of a similar character in this locality, as established by the Department of Labor and Industrial Relations of the State of Missouri. Contractor acknowledges that Contractor knows the prevailing hourly rate of wages for this project because Contractor has obtained the prevailing hourly rate of wages from the contents of **ANNUAL WAGE ORDER NUMBER 26 - COLE COUNTY** in which the rate of wages is set forth. The Contractor further agrees that Contractor will keep an accurate record showing the names and occupations of all workmen employed by Contractor in connection with the work to be performed under the terms of this contract. The record shall show the actual wages paid to the workmen in connection with the work to be performed under the terms of this contract. A copy of the record shall be delivered to the Director of Public Works each week. In accordance with Section 290.250 RSMo., Contractor shall forfeit to the County One Hundred Dollars (\$100.00) for each workman employed, for each calendar day or portion thereof that the workman is paid less than the stipulated rates for any work done under this contract, by the Contractor or any subcontractor under the Contractor.

**3. Contract Sum** The County shall pay the Contractor for the prompt, faithful, and efficient performance of the conditions and undertakings of this contract, subject to additions, and deductions as provided, herein, in current funds the sum of **[Insert Construction Amount]**.

**TOTAL CONTRACT AMOUNT.....\$0,000,000.00**

The County hereby accepts and reserves and the Contractor is hereby bound thereby, Unit Prices of the Proposal submitted as follows:

**UNIT PRICES:**

For changing specified quantities of work from those indicated by the plans and specifications, upon written instructions of the County, the following unit prices shall prevail. The unit prices include all labor, overhead and profit, materials, equipment, appliances, bailing, shoring, shoring removal, etc., to cover the finished work of the several kinds called for. Only a single unit price shall be given and it shall apply for either MORE or LESS work than shown on the plans and called for in the specifications. In the event of more or less units than so indicated or included, change orders shall be issued for the increased or decreased amount.

***Itemized Quantities shall be placed here in awarded contract***

**4. Insurance** Contractor shall procure and maintain at its own expense during the life of this contract:

(a) **Workers Compensation Insurance** for all of its employees to be engaged in work under this contract.

(b) **Contractor's Public Liability Insurance** in an amount not less than \$1,000,000 for all claims arising out of a single occurrence and \$100,000 for any one person in a single accident or occurrence, except for those claims governed by the provisions of the Missouri workers compensation law, Chapter 287, RSMo., and Contractor's Property Damage Insurance in an amount not less than \$800,000 for all claims arising out of a single accident or occurrence and \$100,000 for any one person in a single accident or occurrence.

(c) **Automobile Liability Insurance** in an amount not less than \$1,000,000 for all claims arising out of a single accident or occurrence and \$100,000 for any one person in a single accident or occurrence.

(d) **Owner's Protective Liability Insurance** The Contractor shall also obtain at its own expense and deliver to the County a Owner's Protective Liability Insurance Policy naming the County of Cole as the insured, in an amount not less than \$1,000,000 for all claims arising out of a single accident or occurrence and \$100,000 for any one person in a single accident or occurrence, except for those claims governed by the provisions of the Missouri workmen's compensation law, Chapter 387, RSMo. No policy will be accepted which excludes liability for damage to underground structures or by reason of blasting, explosion, or collapse.

(e) **Subcontracts** In case any or all of this work is sublet, the Contractor shall require the Subcontractor to procure and maintain all insurance required in Subparagraphs (a), (b), and (c) hereof and in like amounts.

(f) **Scope of Insurance and Special Hazard** The insurance required under Subparagraphs (b) and (c) hereof shall provide adequate protection for the Contractor and its subcontractors, respectively, against damage claims which may arise from operations under this contract, whether such operations be by the insured or by anyone directly or indirectly employed by it, and also against any special hazards which may be encountered in the performance of this contract.

**NOTE:** Paragraph (f) is construed to require the procurement of Contractor's protective insurance (or contingent public liability and contingent property damage policies) by a general contractor whose subcontractor has employees working on the project, unless the general public liability and property damage policy (or rider attached thereto) of the general contractor provides adequate protection against claims arising from operations by anyone directly or indirectly employed by the Contractor.

**5. Contractor's Responsibility for Subcontractors** It is further agreed that Contractor shall be as fully responsible to the County for the acts and omissions of its subcontractors, and of persons either directly or indirectly employed by them, as Contractor is for the acts and omissions of persons it directly employs. Contractor shall cause appropriate provisions to be inserted in all subcontracts relating to this work, to bind all subcontractors to Contractor by all the terms herein set forth, insofar as applicable to the work of subcontractors and to give Contractor the same power regarding termination of any subcontract as the County may exercise over Contractor under any provisions of this contract. Nothing contained in this contract shall create any contractual relations between any subcontractor and the County or between any subcontractors.

**6. Liquidated Damages** The Director of Public Works may, at his discretion, deduct **Seven Hundred Dollars (\$700.00)** per day from any amount otherwise due under this contract for every day Contractor fails or refuses to prosecute the work, or any separable part thereof, with such diligence as will insure the completion by the time above below, or any extension thereof, or fails to complete the work by such time, as long as the County does not terminate the right of Contractor to proceed. It is further provided that Contractor shall not be charged with liquidated damages because of delays in the completion of the work due to unforeseeable causes beyond Contractor's control and without fault or negligence on Contractor's part or the part of its agents.

**7. Liquidated Savings** The Director of Public Works may, at his discretion, add **Seven Hundred Dollars (\$700.00)** per day up to a maximum of \$9,800 for every day the project is substantially complete prior to the date specified below.

**8. Termination** The County reserves the right to terminate this contract by giving at least five (5) days' prior written notice to the Contractor, without prejudice to any other rights or remedies of the County should the Contractor be adjudged as bankrupt, or if Contractor should make a general assignment for the benefit of its creditors, or if a receiver should be appointed for Contractor or for any of its property, or if Contractor should persistently or repeatedly refuse or fail to supply enough properly skilled workmen or proper material, or if Contractor should refuse or fail to make prompt payment to any person supplying labor or materials for the work under the contract, or persistently disregard instructions of the County or fail to observe or perform any provisions of the contract.

**8. County's Right to Proceed** In the event this contract is terminated pursuant to Paragraph 6, then the County may take over the work and prosecute the same to completion, by contract or otherwise, and Contractor and its sureties shall be liable to the County for any costs over the amount of this contract thereby occasioned by the County. In any such case the County may take possession of, and utilize in completing the work, such materials, appliance, and structures as may be on the work site and are necessary for completion of the work. The foregoing provisions are in addition to, and not in limitation of, the rights of the County under any other provisions of the contract, County regulations, and state and federal laws.

**9. Indemnity** The Contractor agrees to defend, indemnify, and save the County harmless from and against all claims, suits, and actions of every description, brought against the

County and from all damage and costs by reason or on account of any injuries or damages received or sustained by any person or persons, or their property, by Contractor, its servants, agents, or subcontractors in the construction of said work, or by any negligence or carelessness in the performance of the same, or on account of any act or omission of Contractor, its servants, agents, or subcontractors, or arising out of the award of this contract to Contractor.

**10. Payment for Labor and Materials** The Contractor agrees and binds itself to pay for all labor done, and for all the materials used in the construction of the work to be completed pursuant to this contract. Contractor shall furnish to the County a bond to insure the payment of all materials and labor used in the performance of this contract. The Contractor is aware of, understands and agrees to abide by RSMo. 34.057.

**11. Payment** The County hereby agrees to pay the Contractor for the work done on a monthly basis pursuant to this contract according as set forth in the Contract Documents upon acceptance of said work by the Director of Public Works and in accordance with the rates and/or amounts stated in the proposal of Contractor dated **August 30, 2019**, which are by reference made a part hereof. No partial payment to the Contractor shall operate as approval or acceptance of work done or materials furnished hereunder.

**12. Contract Time** The project covered under this contract shall be completed by no later than **November 22, 2019**.

**13. Contract Documents** The contract documents shall consist of the following:

- |                            |                             |
|----------------------------|-----------------------------|
| a. This Contract           | f. General Conditions       |
| b. Addenda                 | g. Special Provisions       |
| c. Notice to Contractors   | h. Technical Specifications |
| d. Instructions to Bidders | i. Drawings and/or Sketches |
| e. Signed Copy of Bid      |                             |

This contract and the other documents enumerated in this paragraph, form the Contract between the parties. These documents are as fully a part of the contract as if attached hereto or repeated herein.

**14. Nondiscrimination** The Contractor agrees in the performance of this contract not to discriminate on the ground or because of race, creed, color, national origin, or ancestry, sex, religion, handicap, age, or political opinion, or affiliation, against any employee of Contractor or applicant for employment and shall include a similar provision in all subcontracts let or awarded hereunder.

**15. Notices** All notices required to be in writing may be given by first class mail addressed to Cole County Commission, Courthouse Annex, Room 200, 301 East High Street, Jefferson City, Missouri 65101, and **[INSERT CONTRACTOR'S NAME AND MAILING ADDRESS]**. The date of delivery of any notice shall be the second full day after the day of its mailing.

**16. Jurisdiction** This agreement and every question arising hereunder shall be interpreted according to the laws and statutes of the State of Missouri.

**IN TESTIMONY WHEREOF**, the parties have hereunto set their hands and seals as of the day and year below written.

Executed by the **COUNTY** this \_\_\_\_ day of \_\_\_\_\_, 2019.

**COLE COUNTY COMMISSION**, Party of the First Part

\_\_\_\_\_  
Cole County Commission

**ATTEST:**

\_\_\_\_\_  
County Clerk (SEAL)

\_\_\_\_\_  
County Auditor  
*"I certify there is a balance otherwise unencumbered to the credit of the appropriation to which it is to be charged and a cash balance otherwise unencumbered in the treasury to the credit of the fund from which payment is to be incurred."*

Executed by the **CONTRACTOR** this \_\_\_\_ day of \_\_\_\_\_, 2019.

**CONTRACTOR**, Party of the Second Part

By \_\_\_\_\_

\_\_\_\_\_  
Title

**ATTEST:**

\_\_\_\_\_  
Secretary (SEAL)

**CERTIFICATE OF INSURANCE**

Issued at the request of The County of COLE, Missouri

Address: Cole County Commission  
Courthouse Annex, Room 200  
311 East High Street  
Jefferson City, Missouri 65101

THIS IS TO CERTIFY that the insured named below is at this date insured with as described in the following schedule, and in full compliance with the Contract Documents, including all contractual liability coverage.

**DESCRIPTIVE SCHEDULE**

Name of Insured: \_\_\_\_\_

Address of Insured: \_\_\_\_\_

\_\_\_\_\_

Locations Covered: \_\_\_\_\_

\_\_\_\_\_

Description of Work: \_\_\_\_\_

\_\_\_\_\_



**PERFORMANCE, PAYMENT AND ONE YEAR GUARANTEE BOND**

**KNOW ALL MEN BY THESE PRESENTS**, that we, the undersigned \_\_\_\_\_  
\_\_\_\_\_,  
hereinafter referred to as "Contractor" and \_\_\_\_\_  
a Corporation organized under the laws of the State of \_\_\_\_\_, and authorized to  
transact business in the State of \_\_\_\_\_, as Surety, are held and firmly  
bound unto the County of COLE, Missouri hereinafter referred to as "County" in the penal  
sum of \_\_\_\_\_  
\_\_\_\_\_ DOLLARS (\$\_\_\_\_\_),  
lawful money of the United States of America for the payment of which sum, well and truly  
to be made, we bind ourselves and our heirs, executors, administrators, successors, and  
assigns jointly and severally by these presents.

**THE CONDITION OF THE FOREGOING OBLIGATION IS SUCH THAT: WHEREAS**, the  
above bounden Contractor has on the \_\_\_\_\_ day of \_\_\_\_\_, 2019,  
entered into a written contract with the aforesaid County for furnishing all materials,  
equipment, tools, superintendence, labor, and other facilities and accessories, for the  
construction of certain improvements as designated, defined, and described in the said  
Contract and the Conditions thereof, and in accordance with the specifications and plans  
therefore; a copy of said Contract being attached hereto and made a part hereof:

**NOW THEREFORE**, if the said Contractor shall and will, in all particulars, well, duly, and  
faithfully observe, perform, and abide by each and every covenant, condition, and part of  
the said Contract, and the Conditions, Specifications, Plans, Prevailing Wage Law, and  
other Contract Documents thereto attached or, by reference, made a part thereof,  
according to the true intent and meaning in each case, and if said contractor shall replace  
all defective parts, material and workmanship for a period of one year after acceptance by  
the County, then this Obligation shall be and become null and void; otherwise it shall  
remain in full force and effect.

**PROVIDED FURTHER**, that if the said Contractor fails to duly pay for any labor, materials,  
sustenances, provisions, provender, gasoline, lubricating oils, fuel oils, greases, coal  
repairs, equipment, and tools consumed or used in said work, groceries and foodstuffs,  
and all insurance premiums, compensation liability, and otherwise, or any other supplies or  
materials used or consumed by such Contractor or his, their, or its subcontractors in  
performance of the work contracted to be done, the Surety will pay the same in any  
amount not exceeding the amount of this Obligation, together with interest as provided by  
law:

**PROVIDED FURTHER**, that the said Surety, for value received, to be performed  
thereunder, or the specifications accompanying the same, shall in any way affect its  
obligation on this bond and it does hereby waive notice of any change, extension of time,  
alteration, or addition to the terms of the Contract, or to the work, or to the specifications:

**PROVIDED FURTHER**, that if said Contractor fails to pay the prevailing hourly rate of

wages, as shown in the attached schedule, to any workman engaged in the construction of the improvements as designated, defined and described in the said Contract, specifications and conditions thereof, the Surety will pay the deficiency and any penalty provided for by law which the Contractor incurs by reason of (his/its) act or omission, in any amount not exceeding the amount of this obligation together with interest as provided by law:

**IN TESTIMONY WHEREOF**, the said Contractor has hereunto set his hand, and the said Surety has caused these presents to be executed in its name, and its corporate seal to be hereunto affixed, by it attorney-in-fact duly authorized thereunto so to do, at \_\_\_\_\_ this the \_\_\_\_\_ day of \_\_\_\_\_, 20\_\_\_\_\_.

\_\_\_\_\_  
SURETY COMPANY

\_\_\_\_\_  
CONTRACTOR

By \_\_\_\_\_ (SEAL)

By \_\_\_\_\_ (SEAL)

By \_\_\_\_\_ (SEAL)  
Attorney-in-Fact

By \_\_\_\_\_ (SEAL)  
(State Representative)

(Accompany this bond with Attorney-in-Fact's authority from the Surety Company certified to include the date of the bond.)

# Missouri

## Division of Labor Standards

### WAGE AND HOUR SECTION



MICHAEL L. PARSON, Governor

## Annual Wage Order No. 26

Section 026  
**COLE COUNTY**

In accordance with Section 290.262 RSMo 2000, within thirty (30) days after a certified copy of this Annual Wage Order has been filed with the Secretary of State as indicated below, any person who may be affected by this Annual Wage Order may object by filing an objection in triplicate with the Labor and Industrial Relations Commission, P.O. Box 599, Jefferson City, MO 65102-0599. Such objections must set forth in writing the specific grounds of objection. Each objection shall certify that a copy has been furnished to the Division of Labor Standards, P.O. Box 449, Jefferson City, MO 65102-0449 pursuant to 8 CSR 20-5.010(1). A certified copy of the Annual Wage Order has been filed with the Secretary of State of Missouri.

Original Signed by

Taylor Burks, Director  
Division of Labor Standards

Filed With Secretary of State: \_\_\_\_\_ **March 8, 2019**

Last Date Objections May Be Filed: **April 8, 2019**

Prepared by Missouri Department of Labor and Industrial Relations

OCCUPATIONAL TITLE	** Date of Increase	Basic Hourly Rates
<b>Asbestos Worker</b>		<b>\$51.05</b>
Boilermaker		\$24.20*
Bricklayer		\$49.43
Carpenter		\$45.02
Lather		
Linoleum Layer		
Millwright		
Pile Driver		
Cement Mason		\$42.77
Plasterer		
Communications Technician		\$50.10
Electrician (Inside Wireman)		\$50.26
Electrician Outside Lineman		\$24.20*
Lineman Operator		
Lineman - Tree Trimmer		
Groundman		
Groundman - Tree Trimmer		
Elevator Constructor		\$24.20*
Glazier		\$60.75
Ironworker		\$56.98
Laborer		\$37.75
General Laborer		
First Semi-Skilled		
Second Semi-Skilled		
Mason		\$24.20*
Marble Mason		
Marble Finisher		
Terrazzo Worker		
Terrazzo Finisher		
Tile Setter		
Tile Finisher		
Operating Engineer		\$57.54
Group I		
Group II		
Group III		
Group III-A		
Group IV		
Group V		
<b>Painter</b>		<b>\$36.63</b>
Plumber		\$60.73
Pipe Fitter		
Roofer		\$46.97
Sheet Metal Worker		\$53.31
<b>Sprinkler Fitter</b>		<b>\$50.85</b>
Truck Driver		\$24.20*
Truck Control Service Driver		
Group I		
Group II		
Group III		
Group IV		

\*The Division of Labor Standards received less than 1,000 reportable hours as required by RSMo 290.257.4(b). Public works contracting minimum wage is established for this occupational title using data provided by Missouri Economic Research and Information Center, in accordance with RSMo 290.257.2.

Heavy Construction Rates for  
COLE County

Section 026

OCCUPATIONAL TITLE	** Date of Increase	Basic Hourly Rates
Carpenter		\$52.37
Millwright		
Pile Driver		
Electrician (Outside Lineman)		\$24.20*
Lineman Operator		
Lineman - Tree Trimmer		
Groundman		
Groundman - Tree Trimmer		
Laborer		\$43.08
General Laborer		
Skilled Laborer		
Operating Engineer		\$55.67
Group I		
Group II		
Group III		
Group IV		
Truck Driver		\$42.54
Truck Control Service Driver		
Group I		
Group II		
Group III		
Group IV		

Use Heavy Construction Rates on Highway and Heavy construction in accordance with the classifications of construction work established in 8 CSR 30-3.040(3).

Use Building Construction Rates on Building construction in accordance with the classifications of construction work established in 8 CSR 30-3.040(2).

If a worker is performing work on a heavy construction project within an occupational title that is not listed on the Heavy Construction Rate Sheet, use the rate for that occupational title as shown on the Building Construction Rate Sheet.

\*The Division of Labor Standards received less than 1,000 reportable hours as required by RSMo 290.257.4(b). Public works contracting minimum wage is established for this occupational title using data provided by Missouri Economic Research and Information Center, in accordance with RSMo 290.257.2.

# OVERTIME and HOLIDAYS

## OVERTIME

For all work performed on a Sunday or a holiday, not less than twice (2x) the prevailing hourly rate of wages for work of a similar character in the locality in which the work is performed or the public works contracting minimum wage, whichever is applicable, shall be paid to all workers employed by or on behalf of any public body engaged in the construction of public works, exclusive of maintenance work.

For all overtime work performed, not less than one and one-half (1½) the prevailing hourly rate of wages for work of a similar character in the locality in which the work is performed or the public works contracting minimum wage, whichever is applicable, shall be paid to all workers employed by or on behalf of any public body engaged in the construction of public works, exclusive of maintenance work or contractual obligation. For purposes of this subdivision, "**overtime work**" shall include work that exceeds ten hours in one day and work in excess of forty hours in one calendar week; and

A thirty-minute lunch period on each calendar day shall be allowed for each worker on a public works project, provided that such time shall not be considered as time worked.

## HOLIDAYS

January first;  
The last Monday in May;  
July fourth;  
The first Monday in September;  
November eleventh;  
The fourth Thursday in November; and  
December twenty-fifth;

If any holiday falls on a Sunday, the following Monday shall be considered a holiday.

JOB SPECIAL PROVISIONS TABLE OF CONTENTS

(Job Special Provisions shall prevail over General Special Provisions whenever in conflict therewith.)

- A. General
- B. Work Zone Traffic Management Plan
- C. Project Contact for Contractor/Bidder Questions
- D. Utilities
- E. Emergency Provisions and Incident Management
- F. Liquidated Damages / Liquidated Savings for Completion Date
- G. Pre-Construction Conference
- H. Seeding, Fertilizing and Mulch
- I. Mailboxes
- J. Topsoil in Areas to Be Seeded
- K. Construction Staking
- L. Property Corners and Monumentation
- M. Sign Removal
- N. Removal of Improvements
- O. Tack
- P. Performance Graded Asphalt Binder
- Q. Haul Truck Types Prohibited
- R. Approval of Asphalt Mix Design
- S. Verification of Job Mix Formula
- T. Asphalt Cores for Pavement Testing
- U. Reclaimed Asphalt Shingles (RAS)
- V. Reclaimed Asphalt Pavement (RAP)
- W. Transverse Joints (Headers)
- X. Centerline Joint
- Y. Pavement Width Measurement
- Z. Disposal of Asphalt
- AA. Protection of Adjacent Properties
- BB. Earthwork
- CC. Rock Ditch Liner
- DD. Rock Ditch Checks
- EE. Rock Removal
- FF. Undergrading in Rock Cut
- GG. Drainage
- HH. Permits



08-07-2019

**A. GENERAL**

**1.0** The Technical Specifications for this project shall consist of the latest effective version of the Missouri Standard Specifications for Highway Construction except as modified or contradicted by the County's Contract, Special Provisions, General Provisions, Plans and Revisions shown in Section 8 – Technical Specifications. Section 8 consists of revisions to the 1999 version of the Missouri Standard Specifications for Highway Construction.

**2.0** The standard drawings for this project shall consist of the currently effective Missouri Standard Plans for Highway Construction except as modified or contradicted by the County's Contract, Special Provisions, General Provisions, and Plans.

**2.1** Copies of the Technical Specifications and Standard Plans may be found on the MoDOT website at <http://www.modot.org/business/index.htm>.

**3.0** The contractor shall familiarize himself with these drawings and specifications prior to bidding. Failure to do so shall not relieve the contractor from delivering the completed project in accordance with the intent of the Plans and Specifications to provide a workable project.

**3.1** All Construction Details included with the plans and attached hereto shall be used in constructing this project.

**B. WORK ZONE TRAFFIC MANAGEMENT PLAN**

**1.0 Description.** Work zone traffic management supplied by the contractor shall be in accordance with applicable portions of Division 100 and Division 600 of the Standard Specifications, and specifically as follows.

**2.0 Traffic Management Schedule.**

**2.1** Traffic management schedules shall be submitted to the engineer for review prior to the start of work and prior to any revisions to the traffic management schedule. The traffic management schedule shall include the proposed traffic control measures, hours traffic control will be in place, and work hours.

**2.2** The engineer shall be notified as soon as practical of any postponement due to weather, material or other circumstances.

**2.3** In order to ensure minimal traffic interference, the contractor shall schedule lane closures for the absolute minimum amount of time required to complete the work. Lanes shall not be closed until material is available for continuous construction and the contractor is prepared to diligently pursue the work until the closed lane is opened to traffic.

**3.0 Work Hour Restrictions:** There are no work hour restrictions for this project. It shall be the responsibility of the engineer to determine if work hours may be modified. Working hours for evenings, weekends and holidays will be determined by the engineer.

**4.0 Detours and Lane Closures.**

**4.1** The contractor shall notify the county prior to any closures. The contractor shall submit a schedule of closure to the engineer **TWO WEEKS** prior to the closure. The engineer must approve the schedule prior to any work beginning.

**4.2** Local traffic must have access to the area at all times.

**4.3** When closing the road, the contractor shall place Type III Movable Barricades with R11-2 signs and Type C warning lights at the road closure. The contractor shall also place W020-1 and R11-3a signs in advance of any road work or closure. The signs shall be in accordance with MoDOT's Engineering Policy Guide and approved by the Engineer. If the contractor has to do any miscellaneous work before and/or after the road closures, he shall provide temporary traffic control in accordance with the Manual on Uniform Traffic Control Devices. This shall include but not be limited to, signing, flagging, cones, etc.

**4.4** The Contractor shall install detour signing as shown on the plans.

**4.5** Where one lane of the road is closed, the contractor shall utilize a flagger to maintain traffic on the adjacent lane unless otherwise approved by the field engineer.

**5.0 Property Owner Coordination:** Contractor must coordinate with adjacent property owners to schedule construction of the entrance. Contractor shall provide property owners access to their property at all times by use of phased construction, shared entrances, temporary entrances, or other means necessary. Property access closures may be allowed with permission of property owner and approval of the Engineer.

**6.0 Basis of Payment:** Any expenses incurred by the contractor by reason of their compliance with this provision shall be considered as completely covered by project bid items.

## **C. PROJECT CONTACT FOR CONTRACTOR/BIDDER QUESTIONS**

**1.0** All bidding related questions concerning this project shall be forwarded to the project contact listed below.

Eric Landwehr, P.E., Project Contact  
County Engineer  
Cole County Public Works  
5055 Monticello Road  
Jefferson City, MO 65109-9182  
Telephone Number (573) 636-3614  
Fax Number (573) 636-8389  
Email [elandwehr@colecounty.org](mailto:elandwehr@colecounty.org)

**2.0** All questions concerning the plans and specifications can be directed to the contact below.

Patrick Kremer, P.E.  
Central Missouri Professional Services, Inc.  
2500 E. McCarty St.  
Jefferson City, MO 65101  
Telephone Number (573) 634-3455  
Fax Number (573) 634-8898  
Email [pkremer@cmpps-inc.com](mailto:pkremer@cmpps-inc.com)

**D. UTILITIES**

**1.0** The location and extent of the existing underground utilities and other utilities shown on the plans may not be totally accurate or all inclusive. It shall be the sole responsibility of the contractor to locate, protect, and restore all existing utilities encountered on the project. Notify Missouri One Call (1-800-DIG-RITE) for location of the utilities at least five days prior to the construction.

**1.1** The contractor shall be aware of the presence of utilities above and/or below the ground or in the vicinity of this project that may interfere with their operations. The contractor expressly acknowledges and assumes this risk even though the nature and extent is unknown to both the contractor and the owner at the time of bidding and award of the contract. The effect in cost or time of the presence of utilities above, below or in the vicinity of the contractor's work under this contract shall not be compensable.

**1.2** The contractor agrees that any effects of the presence of the utilities, their relocation, contractor's coordination of work with the utilities and any delay in utility relocation shall not be compensable as a suspension of work, extra work, a change in the work, as a differing site condition or otherwise including but, without limitation, delay, impact, incidental or consequential damages. The contractor's sole remedy for the effects of the presence of utilities, delay in their relocation or any other effects shall be an excusable delay as provided in Section 105.7.3. The contractor waives, for itself, its subcontractors and suppliers the compensability of the presence of utilities, delay in their relocation and any cost to the contractor, its subcontractors and suppliers in any claim or action arising out of or in relation to the work under the contract.

**1.3** The contractor shall be solely responsible and liable for incidental and consequential damage to any utility facilities or interruption of the service caused by it or its subcontractors operation. The contractor shall hold and save harmless the owner from damages to any utility facilities interruption of service by it or its subcontractor's operation.

**1.4** The contractor shall coordinate with utility companies to allow the utilities to inspect any exposed lines that are to remain in place before being backfilled. Any damage to the utilities that occurred during construction shall be repaired or replaced at the expense of the contractor.

**1.5** In addition to general utility conflicts and crossings, the contractor is made aware of the specific utility conflicts made below.

1. Three Rivers Electric has utility poles and underground electric lines within the project construction limits. Ameren Electric plans to relocate all conflicting lines ahead of construction.
2. Public Water Supply District #2 has waterlines within the project construction limits that will be impacted. Relocation is to be done by the contractor. Details for the water line work are included in the plans and bid items are shown in the proposal. Materials will be supplied by PWSD#2
3. CenturyLink has telephone lines to be relocated during construction.

**2.0** It shall be noted by the contractor that the owner is a member of Missouri One Call (800 Dig Rite). Some work on this project may be in the vicinity of utility facilities, which includes but are not limited to those identified on the plans. Prior to beginning work, the contractor shall request locates from Missouri One Call. The contractor shall also notify the engineer by fax (573-636-

8389). The notice must be submitted a minimum of 2 and a maximum of 10 working days prior to work just as Missouri One Call requires.

**3.0 Basis of Payment:** No direct pay will be made to the contractor to recover the cost of the communication equipment, labor, materials or time required to fulfill the above provisions.

## **E. EMERGENCY PROVISIONS AND INCIDENT MANAGEMENT**

**1.0** The contractor shall have communication equipment on the construction site or immediate access to other communication systems to request assistance from the police or other emergency agencies for incident management. In case of traffic accidents or the need for police to direct or restore traffic flow through the job site, the contractor shall notify police or other emergency agencies immediately as needed. The project contact's office shall also be notified when the contractor requests emergency assistance.

**2.0** In addition to the 911 emergency telephone number for ambulance, fire or police services, the following agencies may also be notified for accident or emergency situation within the project limits.

Cole County Sheriff	(573) 634-9160
Cole County EMS	(573)-634-2616
Cole County Fire Protection District	911 (Emergency) (573) 634-9011 (Non-Emergency)
Missouri State Highway Patrol	(573) 751-1000

**2.1** This list is not all inclusive. Notification of the need for wrecker or tow truck services will remain the responsibility of the appropriate police agency.

**2.2** The contractor shall notify enforcement and emergency agencies before the start of construction to request their cooperation and to provide coordination of services when emergencies arise during the construction at the project site. When the contractor completes this notification with enforcement and emergency agencies, a report shall be furnished to the engineer on the status of incident management.

**3.0 Basis of Payment:** No direct pay will be made to the contractor to recover the cost of the communication equipment, labor, materials or time required to fulfill the above provisions.

## **F. LIQUIDATED DAMAGES / LIQUIDATED SAVINGS FOR COMPLETION DATE**

**1.0 Description.** The Contractor is advised that the project must be substantially complete by **November 22, 2019**.

**1.1** Substantial completion is defined as the completion of all pay items with the exception of final seeding.

**1.2** If the project is not substantially complete by **November 22, 2019**, the County, the traveling

public, and local police and governmental authorities will be damaged in various ways including but not limited to potential liability, traffic and traffic flow regulation cost, traffic congestion, and motorist delay, with its resulting cost to the traveling public.

**2.0 Liquidated Damages for Failure to Complete Work on Time.** These costs are not reasonably capable of being computed or quantified. Therefore, the Contractor will be charged with liquidated damages specified in the amount of **\$700 per calendar day for each full calendar day** that the project is not substantially complete after **November 22, 2019**. This deduction will continue until such time as the project is substantially complete.

**2.1** Revise Section 108.8.1.2 (a) and (b) and substitute the following for this project:

- (a) Liquidated damages will be assessed from December 15 to March 15.
- (b) Liquidated damages will be assessed for Saturdays, Sundays, and Holidays.

**3.0 Liquidated Savings for Early Completion.** The Contractor may receive an incentive payment from the County, in addition to all other sums earned under the contract, if the project is substantially complete prior to **November 22, 2019**. An incentive payment of **\$700 per calendar day for each full calendar day** that the work described above is completed prior to **November 22, 2019**. The maximum amount paid as liquidated savings shall not exceed **\$9,800**.

**1.1** In the event of an excusable delay, an extension of the contract completion time will not extend the date specified for determining any liquidated savings or incentive. Further, in the event of an excusable delay, if the Contractor completes the work providing for liquidated savings or incentive on or before the completion date, that shall not constitute a basis to claim acceleration costs in addition to the liquidated savings or incentive that may be earned.

**1.2** The incentive payment described is made, not as bonus or gift, but as stipulated compensation in full for reduced risks, delay and inconvenience experienced by the traveling public, and for other reduced costs to the County and the public resulting from early completion.

## **G. PRE-CONSTRUCTION CONFERENCE**

**1.0** Prior to starting work, a pre-construction conference will be held to discuss the project, it's scheduling and it's coordination with the work of others. It is expected that this conference will be attended by representatives of the Owner, the Engineer, the Contractor and his Subcontractors, and the Utilities, as well as representatives of any other affected agencies which the Owner may wish to invite.

**1.1** It shall be required that all of the contractor's designated foremen that will oversee field operations of the project will attend the conference.

**1.2** The work schedule specified in the Instructions to Bidders will be submitted at the conference.

## **H. SEEDING, FERTILIZING AND MULCH**

**1.0** Final grade shall be established and seeded within 10 working days of proposed improvements being completed on a property unless approved otherwise by the Engineer.

**1.1** All disturbed areas of the project not paved or concrete shall be seeded. The seed mixture shall be 80% Millennium Fescue, 10% Pizzazz Rye, and 10% Brooklawn Bluegrass. The seeding rate shall be 350 lbs/acre (0.72 lb/sy).

**1.2** Fertilizer shall be a standard commercial product which, when applied at the proper rates shall supply the quantity of total nitrogen (N), available phosphoric acid (P<sub>2</sub>O<sub>5</sub>) and soluble potash (K<sub>2</sub>O) to provide a final mixture of 13-13-13. The rate of application shall be 500 pounds per acre of 13-13-13 fertilizer. Material may be accepted on the basis of bag label analysis or supplier's certification, or on the basis of samples tested in the laboratory. For samples tested in the laboratory, tolerances in the nominal composition as shown by label or certification of 10 percent up to the maximum of two units (2% plant food) for the individual constituents, and minus 3 percent for the sum of the constituents, will be permitted. There is no limit on the plus tolerances for such samples.

**1.3** Type 1 Mulch (Vegetative) shall be applied at the rate of 1 ½ tons per acres.

**1.4** Payment for seeding work will be made on the following schedule:

- 50% paid after seeding and mulch is placed.
- 50% paid after seeding has been established and County accepts it.

**2.0 Basis of Payment.** All costs incurred by the contractor for labor, equipment and materials in compliance with the above requirements including seedbed preparation, liming, furnishing and placing fertilizer and mulch, shall be considered completely covered by the unit price for "Seeding, Fertilizing and Mulch", per lump sum.

## **I. MAILBOXES**

**1.0** If U.S. Postal Service access to any mailboxes will be interrupted during construction, the contractor shall contact the U.S. Postal Service to determine where the mailboxes should be set during construction.

**1.1** Any mailboxes that need to be removed during construction shall be temporarily relocated to ensure that mail delivery is uninterrupted.

**1.2** Mailboxes shall be reset at appropriate locations by the contractor once work is complete. The contractor shall reset in the locations as directed by the engineer and to the standards required by the U.S. Postal Service and the plans.

**1.3** Any materials damaged by the contractor shall be replaced with material of equal or better type and quality at the contractor's expense.

**2.0 Basis of Payment:** All expenses incurred by the contractor by reason of their compliance with these requirements shall be considered as being included in and completely covered by the contract unit prices for the various items included in the contract.

**J. TOPSOIL IN AREAS TO BE SEEDED**

**1.0** The top six (6) inches of all areas of the project to be vegetated shall be free of rocks, stones and clods prior to seeding or sodding. This may require the contractor to utilize a mechanical rock rake, hand picking of stones, and/or placement of six (6) inches of clean topsoil in those areas to be vegetated. All areas to be vegetated shall be inspected prior to seeding or sodding and any deficiency shall be corrected prior to application.

**2.0 Basis of Payment:** All costs associated with the work specified under this provision shall be considered completely covered by the various items of work in the contract.

**K. CONSTRUCTION STAKING**

**1.0** Construction staking for this project will be performed by the County or its agent. The contractor shall provide one week's notice of any staking he wishes to have performed. Any restaking required due to the destruction of the original stakes shall be the responsibility of the contractor.

**L. PROPERTY CORNERS AND MONUMENTATION**

**1.0** It shall be the responsibility of the Contractor to protect all property lot corners and land survey corners and accessories. Should it be necessary to disturb any such monument, whether stake, pin, bar, disk, box, or other, the Contractor shall contact the County prior to construction. The County will reference such markers prior to removal and reset them after construction. The Contractor shall allow the County a minimum of 2 working days to reference such markers.

**2.0** No direct payment will be made to the contractor for the requirements of this provision.

**M. SIGN REMOVAL**

**1.0** The contractor shall use care when removing existing signs and posts to not cause any damage. The contractor shall stockpile the signs and posts in a location as directed by the Engineer. The County will reinstall the signs at a later date.

**2.0 Basis of Payment:** Any expenses incurred by the contractor by reason of their compliance with this provision shall be considered as completely covered by Item No. 202-20.10, "Removal of Improvements", per lump sum.

**N. REMOVAL OF IMPROVEMENTS**

**1.0** All removal of improvements necessary for the completion of the project in accordance with the plans shall be considered completely covered by Item No. 202-20.10 "Removal of Improvements", per lump sum. These removal items shall consist of but not be limited to:

- Concrete Driveways, Approaches
- Asphalt pavement

- Pipe removal
- Vinyl fence removal
- Existing fencing and gates
- Existing signs and posts
- Removal and replacement of mailboxes
- Existing water main, valves and hydrants to be replaced

**3.0 Basis of Payment.** There will be no direct payment for pavement removal, all costs associated with the requirements in this specification shall be considered completely covered by "Removal of Improvements", per lump sum.

## **O. TACK**

**1.0** On full depth pavements, the bituminous base layer shall be tacked prior to laying the bituminous pavement surface layer. The existing surfaces shall be swept free of all dust, loose material, grease or other foreign material at the time the tack is applied.

**2.0** All tacked surfaces shall be overlaid with a bituminous mixture within the same day. At no time shall a tacked surface be left in an unpaved condition overnight. In addition, the tack distribution vehicle shall not tack beyond the limits of the traffic control.

**3.0 Basis of Payment.** This work shall be considered incidental to the placement of the asphalt. All costs associated with this work shall be considered completely covered by the pavement bid items.

## **P. PERFORMANCE GRADED ASPHALT BINDER**

**1.0** The asphalt binder for the asphalt mixes for this project shall be performance graded. The grade shall be PG 64-22 and shall be in compliance with the Section 1015 of the Specifications.

## **Q. HAUL TRUCK TYPES PROHIBITED**

**1.0** End dump trucks consisting of a separate tractor and trailer design shall not be permitted to haul for this project. All other trucks will be evaluated in conjunction with the haul route. The County reserves the right to prohibit the use of any truck or the use of certain roads at any time for the duration of the project.

## **R. APPROVAL OF ASPHALT MIX DESIGN**

**1.0** The asphalt mix design shall be submitted to the County for verification and approval at least 15 days prior to placing any mixture on the project. All applicable portions of Sec. 401.4 shall apply. The contractor shall not begin work until approval of the mix design has been given by the County.

**S. VERIFICATION OF JOB MIX FORMULA**

1.0 In accordance with Sec. 401.5 (d), the quantity of asphalt binder introduced into the mixer shall be the quantity specified in the job-mix formula. No changes shall be made to the quantity of asphalt binder without written approval from the engineer. The contractor shall furnish verification of the asphalt binder content in the mixer at any time immediately upon request.

**T. ASPHALT CORES FOR PAVEMENT TESTING**

1.0 The contractor shall perform pavement testing in accordance with Sec. 401.8.4. After samples are taken, the contractor shall restore the surface by no later than the next calendar day with the mixture under production or with a cold patch mixture acceptable to the engineer. Any core holes not restored by the next calendar day will be filled by the County. The contractor will be charged \$500 for each hole filled by the County, and this will be deducted from final payment at contract closeout.

**U. RECLAIMED ASPHALT SHINGLES (RAS)**

1.0 Reclaimed asphalt shingles will be allowed per MoDOT Specifications with the following exception:

No Reclaimed Asphalt Shingles (RAS) shall be included in any Plant Mix Bituminous Pavement (BP-1) mixture used on this project.

**V. RECLAIMED ASPHALT PAVEMENT (RAP)**

1.0 Reclaimed asphalt pavement will be allowed per MoDOT Specifications with the following exception:

No Reclaimed Asphalt Pavement (RAP) shall be included in any Plant Mix Bituminous Pavement (BP-1) mixture used on this project.

**W. TRANSVERSE JOINTS (HEADERS)**

1.0 Transverse joints or headers, except at coldmilled butt joints, shall not be allowed in a continuous lane unless prior approval is authorized by the engineer at least two (2) days in advance.

**X. CENTERLINE JOINT**

1.0 When paving a road or location requiring more than one lane pass of the paver, the centerline joint between the two lanes shall be reasonably straight as determined by the engineer. Joints will be checked by a straight edge or string line. Any major deviations as determined by the Engineer shall be immediately corrected prior to the first pass of the breakdown roller.

**2.0 Basis of payment.** All costs associated with this provision shall be considered included in and completely covered by the various items of work in the contract.

#### **Y. PAVEMENT WIDTH MEASUREMENT**

**1.0** Measurement for all asphalt pavement bid items shall be made from the top width of the pavement which is 22'. The contractor shall include in their bid any work or materials necessary to meet this requirement. Underlying base or pavement layers shall be wider to accommodate a 22' wide pavement top.

**2.0** There shall be no direct pay to the contractor for meeting this provision.

#### **Z. DISPOSAL OF ASPHALT**

**1.0** Removed asphalt may not be disposed of beyond the edge of pavement. Any asphalt removed from the existing roadway, including millings, must be disposed of within the proposed roadway width and incorporated into the subgrade or at another site.

#### **AA. PROTECTION OF ADJACENT PROPERTIES**

**1.0** Surface water shall be diverted and otherwise prevented from entering or damaging adjacent property as a result of precipitation during construction.

#### **BB. EARTHWORK**

**1.0 Description.** This work shall consist of all grading and excavation work required or necessary for the total completion of the project, except as noted elsewhere.

**1.1** Typical earthwork items on this project shall consist of but not be limited to:

- Linear grading for ditch.
- Class 3 Excavation for pipes.
- Excavation required for driveway work.
- Excavation of poor soil in the yard areas.
- Furnishing and placing top soil.
- Fill areas for proper yard drainage
- Excavating or filling to the limits shown on the plans.
- Hauling of waste material off site.

#### **2.0 Construction Requirements.**

**2.1** Grading activities shall conform to Sec. 203 and other applicable areas of the Standard Specifications.

**2.2** All earth excavation that is required for pipe installation shall be included in the unit bid price of pipe per linear foot.

**3.0 Rock Excavation**

**3.1** Depth of bedrock was not investigated outside of inlet locations for this project. All rock encountered for the excavation of inlets and pipes shall be considered completely covered by Item No. 203-99.01 "Earthwork", per lump sum.

**3.2** Class 3 excavation will be encountered during the water main relocation. It shall be considered completely covered by the unit bid item for "Class 3 Excavation in Rock", per CY.

**4.0 Method of Measurement.** No measurements will be made and contract quantity will be used.

**5.0 Basis of Payment.** All costs incurred for equipment, labor, materials or time required to fulfill this provision, except as noted above, shall be considered completely covered by the contract unit price for "Earthwork", per lump sum.

**CC. ROCK DITCH LINER**

**1.0 Description.** This work shall consist of constructing rock ditch liner at the location shown on the plans or as directed by the engineer.

**2.0 Material.** The Rock shall consist of material conforming Section 611 for the requirements for Type 2 Rock Blanket.

**3.0 Construction Requirements.** The rock ditch liner shall be placed to the approximate shape and thickness shown on the plans or as directed by the engineer. The rock shall be dumped on a subgrade of reasonable uniform density and shall be flushed with water before placing the grout to remove fines from the rock surfaces.

**4.0 Method of Measurement.** Rock ditch liner will be measured to the nearest cubic yard of material in place.

**5.0 Basis of Payment.** Placing of rock ditch liner will be paid for at the contract unit price per cubic yard. All work required to provide, and place material shall be considered completely covered by the unite price bid for "Rock Ditch Liner", per cubic yard.

**DD. ROCK DITCH CHECKS**

**1.0 Description.** This work shall consist of furnishing, constructing, maintaining, removing and depositing of temporary rock ditch checks.

**2.0 Construction Requirements.** Rock ditch checks shall be constructed to comply with Section 806, or as directed by the engineer, and shall have a minimum effective height of 9 inches.

**3.0 Maintenance.** The contractor shall monitor the condition of all temporary checks and repair checks that are not functional.

- 3.1** The contractor shall monitor sediment levels and remove sediment prior to the level reaching approximately one-half the design height. The engineer may require sediment removal from devices prior to levels reaching the specific limits.
- 4.0 Removal.** All temporary checks shall remain in service until removal has been approved by the engineer. Removal shall be in accordance with Sec 806.4.11 and as stated herein. The contractor shall remove any sediment from the check, remove the check, and restore the area to match existing ground conditions.
- 5.0 Method of Measurement.** Measurement of rock ditch checks will be made per each check.
- 6.0 Basis of Payment.** All expenses incurred by the contractor shall be completely covered by the unit price bid for "Erosion Control", per lump sum.

## **EE. ROCK REMOVAL**

**1.0** No explosives shall be used on this project without prior approval of the engineer. Rock in these areas shall be removed by mechanical chipping, jack-hammering or other methods approved by the Engineer. Payment for such work shall be considered included in and completely covered by "Earthwork" per lump sum.

## **FF. UNDERGRADING IN ROCK CUT**

**1.0** Sec 203 specifies that rock cut areas are to be undercut and backfilled with a drainable material with top surface choked with fines for proper subgrade preparation. No direct payment shall be made for backfill materials.

## **GG. DRAINAGE**

**1.0 Description:** This work consists of installing crossroad pipes, driveway pipes and flared end sections.

**2.0 Requirements:** Dimensions and details shall be in accordance with the plans and specifications and the applicable section of the currently effective Missouri Standard Specifications for Highway Construction and Missouri Standard Plans for Highway Construction.

**2.1** The Engineer shall be notified at least one day prior to installation of all crossroad pipes. The County will have an inspector present during these installations.

**2.2** All corrugated metal pipe shall have 2-2/3" x 1/2" corrugations unless otherwise specified.

**2.3** Corrugated metal pipe gauges shall be as follows:

Pipe Diameter (in)	Gauge
15	14
18	14
24	14
30	12

**2.4** All reinforced pipe shall be Class III.

**3.0 Method of Measurement:** Measurement of pipe shall be to the nearest 1.0 lineal feet. Flared end sections shall be measured per each.

**3.1** Concrete pipe is cast in sections. The contractor may choose to lay extra pipe rather than cut off a section but the extra length will not be paid.

**4.0 Basis of Payment:** Earth excavation and backfill shall be included with the price for the pipes. If rock is encountered, Class 3 excavation shall be paid at the contract unit price for the water main class 3 excavation.

**4.1** All expenses incurred by the contractor by reason of their compliance with this provision shall be considered as completely covered by the various bid items.

## **HH. PERMITS**

**1.0 MoDNR Land Disturbance Permit.** The County of Cole has obtained a General Operating Permit (Permit No. MO-R100034) from the Missouri Department of Natural Resources, Water Protection Program for construction and land disturbance activity, which covers the work entailed in the project. The County's associated Storm Water Pollution Prevention Plan (SWPPP), which is a requirement to the General Operating Permit, is attached as part of the contract documents.

**1.1** In signing the contract, the contractor obligates himself to follow the provisions of the permit and the associated Storm Water Pollution Prevention Plan. The Contractor shall obtain a copy of the permit and SWPPP prior to beginning construction. Specifically the contractor shall be responsible for:

- a) All required inspections of erosion control BMP's.
- b) Maintaining records of precipitation.
- c) Maintaining logs of BMP Inspections, BMP Maintenance, and BMP Corrective Actions taken to correct deficiencies identified during inspections.
- d) Documenting any changes made to the Erosion Control Plan.

**2.0** A U. S. Army Corps of Engineers nationwide permit (NWP) 14 – Linear Transportation Projects, will be obtained for the impacted stream crossings on this project. If obtained before the bid date the permit will be issued with an addendum. If obtained after the bid date, the contractor will be given a copy of it to include with the contract documents. The contractor shall follow all provisions of this permit.

**3.0 Basis of Payment.** All expenses incurred by the Contractor by reason of their compliance with this provision shall be considered as completely covered by each of the appropriate pay items included in the contract.



## GENERAL SPECIAL PROVISIONS

The General Special Provisions for this particular Cole County project shall consist of the currently corrected (2004) version of the *Missouri Standard Specifications for Highway Construction*, Sections 101 through 110, except as modified or contradicted herein.

### **SECTION 101.2 - DEFINITION OF TERMS**

**Delete definition for “Commission” and substitute the following:**

If the words "Commission" or "The Missouri Highway and Transportation Commission" are used in the *Missouri Standard Specifications for Highway Construction*, the word "Owner" shall be substituted, and shall mean the County of COLE acting by and through any of its authorized representatives.

**Delete definition for “Contract” and substitute the following:**

**Contract.** The written agreement between the Owner and the Contractor covering the performance of the work for the proposed construction. The contract shall include Notice to Contractors, Instruction to Bidders, Plans, Proposal, Addenda, Contract Bond, Contract Agreement, Acknowledgment, Special Provisions, Standard Specifications, Notice to Proceed, and all Supplemental Contracts and Change Orders. It may cover a single project, or a combination of projects awarded as a single unit.

**Delete definition for “Engineer” and substitute the following:**

If the words "Engineer" or "Chief Engineer" are used in the *Missouri Standard Specifications for Highway Construction*, the word "Engineer" shall be substituted, and shall mean the County Engineer acting by and through any of his authorized representatives.

**Delete definition for “Laboratory” and substitute the following:**

**Laboratory.** Any testing laboratory which may be designated by the Engineer, for inspecting and determining the suitability of materials.

**Delete definition for “Plans” and substitute the following:**

**Plans.** Drawings or reproductions thereof approved by the Owner, which show the location, character, and details of the work. Plans shall prevail over standard specifications, general special provisions, and job special provisions when in conflict therewith.

**Insert the following definition for “Job Special Provision” where none currently exists:**

**Job Special Provisions.** Directions or requirements, peculiar to the work and not otherwise thoroughly or satisfactorily detailed or set forth in the standard specifications. Job special provisions shall prevail over general special provisions, and general special provisions shall prevail over standard specifications whenever in conflict therewith.

**Delete definition for “State” and substitute the following:**

If the words "State" or "State of Missouri" are used in such a manner which implies ownership of the project, the word "Owner" shall be substituted and shall mean the County of COLE acting by and through any of its authorized representatives.

## **SECTION 102 - BIDDING REQUIREMENTS AND CONDITIONS**

**Delete Sec. 102.1 and substitute the following:**

**102.1 Notice of Bid Opening.** After the date is fixed for the receipt of bids, the Owner may, in addition to the notice required by law, give notice of such date by mail directly to interested Contractors. The Notice of Letting will contain a description of the proposed work, together with instructions and information to the potential bidder regarding proposal forms, plans, specifications, and the reservation of the right of the Owner to reject any and all bids.

**Delete Sec. 102.2 thru Sec. 102.2.1 and substitute the following:**

**102.2 Bidder’s Qualifications.** To demonstrate his qualifications for the project, each bidder must be prepared to submit within seven (7) calendar days of the Owner’s request, written evidence as to the Contractor’s financial status, equipment, previous experience and personnel.

**Delete Sec. 102.2.2 and substitute the following:**

**102.2.2** Each prospective bidder shall execute the affidavit of labor standards compliance, stating that such bidder will fully comply with all written requests by the Missouri Department of Labor and Industrial Relations, Division of Labor Standards, to provide information for the purpose of establishing a prevailing wage.

**Delete Sec. 102.2.3 and substitute the following:**

**102.2.3** The prospective bidder, if a corporation, shall submit a copy of its current annual registration report, or initial registration report if a new corporation, on file with the Corporation Division of the Missouri Secretary of State’s Office. Each corporation which is a party to a joint venture shall submit the same required report with its joint venture contractor.

**Delete 102.6 and substitute the following:**

**102.6 Sales and Use Taxes.** The sales tax exemption for public works contractors of certain entities, enacted in 1994 in Section 144.062 RSMo, may apply to contractors for the Owner or their subcontractors or suppliers. This exemption is for materials consumed in the construction of, or incorporated into this project. The Owner will judge each project and determine if the sales tax exemption of the Owner will apply. If sales tax exemption is allowed on a project, it will be duly noted on the proposal form. The Owner will make the tax exemption certificate available, if applicable, to the successful bidder upon award of this contract. If the Owner does not allow the use of sales tax exemption, the contractor, subcontractor or suppliers shall pay all applicable state and local sales taxes or state use taxes on all material and supplies used on a project and should include those taxes in their bid.

**Delete 102.7.2 in its entirety.**

**Delete Sec. 102.7.3 and substitute the following:**

**102.7.3** A bid of an individual, including those doing business under a fictitious name, shall include the signature and address of the individual.

**Delete Sec. 102.7.4 and substitute the following:**

**102.7.4** A bid by a partnership or joint venture, including individuals doing business under fictitious names, or corporations, shall be executed by at least one of the partners followed by the title "Partner", or one of the joint venturers followed by the title "Joint Venturer" and the business address of the partnership or joint venturer shown. The true legal name and address of each partner and joint venturer shall also be shown.

**Delete Sec. 102.7.5 and substitute the following:**

**102.7.5** A bid by a corporation whether acting alone or as a joint venturer, shall show the address and name of the corporation and shall include the signature and title of a person authorized by its board of directors to bind the corporation.

**Add Section 102.7.9**

**102.7.9** All names must be typed or printed in ink below all signatures.

**Add Section 102.7.10**

**102.7.10** The bid shall contain an acknowledgement of receipt of all addenda (the number and dates of which shall be filled in on the Proposal Form).

**Add Section 102.7.11**

**102.7.11** All bidders shall complete and submit with their proposal the following forms included in the bid documents.

- (a) Proposal
- (b) Signature and Identity of Bidder
- (c) Bid Guaranty
- (d) Contractor's Affidavit
- (e) Anti-Collusion Statement

**Delete Sec. 102.9 and substitute the following:**

**102.9 Bid Guaranty.** No proposal will be considered unless accompanied by a certified check or cashier's check, on any bank or trust company, insured by the Federal Deposit Insurance Corporation, payable to the Owner, for not less than 5 percent of the amount of the bid, or by a bond secured by a qualified surety, or sureties, for not less than 5 percent of the amount of the bid. Surety companies shall furnish a Certificate of Authority in accordance with Section 103.4.2. Bid bonds may be submitted on forms furnished in these Contract documents. The proposal Guaranty shall be attached to the back of the bid proposal form.

**Delete Sec. 102.10 and substitute the following:**

**102.10 Delivery of Proposals.** Each proposal shall be submitted in a sealed, opaque envelope marked clearly "Construction Bid" and shall also be clearly marked with project title, project number, bid date, bid time and bidder's name and address. If sent by mail, the sealed bid shall be addressed to the Cole County Commission, Courthouse Annex, Room 200, 311 East High Street, Jefferson City, Missouri, 65101. All proposals shall be filed prior to the time and at the place specified in the Notice To Bidders. Proposals received after the time for opening of bids will be returned to the bidder unopened. No bids which are submitted by fax will be accepted.

**SECTION 103 - AWARD AND EXECUTION OF CONTRACT**

**Delete Sec. 103.2.1 and substitute the following:**

**103.2.1** The contract will be awarded by the Owner to the lowest responsible bidder as soon as practicable after the opening of the bids. The responsibility of the Contractor will be determined by the Owner based upon, but not limited to the Contractor's previous work, financial standing, and record for the payment of local bills incurred by the Contractor, his employees, and subcontractors. The successful bidder will be notified by letter mailed to the address shown on the proposal that his bid has been accepted and that he has been awarded the contract.

**Delete Sec. 103.4.1 and substitute the following:**

**103.4.1** The successful bidder shall, at the time of the execution of the contract, furnish a contract bond in a sum equal to the contract price. The bond shall be to the Owner, in a form and with surety, or sureties, acceptable to the Owner, to insure the proper and prompt completion of the work in accordance with the provisions of the contract, and to

insure payment for all labor performed and materials consumed or used in the work. The bond, if executed by a surety which is a corporation organized in a state other than Missouri, shall be signed by an agent or broker licensed by the Missouri Division of Insurance. All proposals shall be submitted on the basis of furnishing a contract bond executed by an approved surety, or sureties, as herein set out.

## **SECTION 104 - SCOPE OF WORK**

### **Add Sec. 104.6.3.5**

**104.6.3.5** All proposals shall be submitted to the Engineer. If so desired, the Contractor may submit a conceptual proposal for approval stating the basic proposal and approximate cost savings. The conceptual proposal will give the Contractor the opportunity to submit his idea without large initial development costs should the proposal be rejected.

### **Delete Sec. 104.11.2 and substitute the following:**

**104.11.2** The Contractor shall open and clean all existing channels and culverts leaving them free from all excess mud or silt, drift, brush, and debris of any kind. This work shall be considered incidental to the work, and no direct payment shall be made for work covered by this section.

### **Delete Sec. 104.13 in its entirety and substitute the following:**

#### **104.13 Warranty.**

**104.13.1** The Contractor shall warranty that the equipment, materials, and workmanship furnished under this contract will be as specified and will be free from defects for a period of one (1) year from the date of final acceptance. In addition, the equipment furnished by the Contractor shall be warranted to be free from defects in design.

**104.13.2** Within the warranty period and upon notification of the Contractor by the Owner, the Contractor shall promptly make all needed adjustments, repairs, or replacements arising out of defects which, in the judgment of the Engineer, or the County, become necessary during such period.

**104.13.3** The cost of all materials, parts, labor, transportation, supervision, special tools, and supplies required for replacement of parts, repair of parts, or correction of abnormalities shall be paid by the Contractor, or by his surety under the terms of the bond.

**104.13.4** The Contractor shall extend the terms of this warranty to cover repaired parts and all replacement parts furnished under the guarantee provisions for a period of one (1) year from the date of installation thereof.

**104.13.5** If within ten (10) days after the Owner gives the Contractor notice of a defect, failure, or abnormality of the work, the Contractor neglects to make, or undertake

with due diligence to make, the necessary repairs or adjustments themselves or order the work to be done by a third party, the Owner may complete the work and the costs of the work shall be paid by the Contractor.

**104.13.6** In the event of an emergency where, in the judgment of the Owner, delays would cause serious loss or damage, repairs or adjustments may be made by the Owner, or a third party chosen by the Owner, without giving notice to the Contractor, and the cost of the work shall be paid by the Contractor, or by his surety under the terms of the bond.

**104.13.7** No direct payment will be made for complying with the requirements of this section.

## **SECTION 105 - CONTROL OF WORK**

**Delete Sec. 105.5 and substitute the following:**

**105.5 Cooperation by Contractor.** The Contractor will be supplied with four (4) sets of approved plans and contract assemblies including special provisions. Additional sets of approved plans and contract assemblies including special provisions may be purchased as provided in the notice to bidders. One (1) set of approved plans and contract documents including special provisions shall be kept available on the job at all times.

**Add Sec. 105.5.3:**

**105.5.3** The Contractor shall notify the Engineer not less than four (4) working days prior to closing the road.

**Delete Sec. 105.7.1 and substitute the following:**

**105.7.1** The Contractor shall cooperate with utility owners and the Engineer in the location and relocation of utility facilities to minimize effects upon Contractor's work, interruption to utility service and duplication of work by utility owners. The Contractor shall perform the necessary clearing and grubbing as soon as practicable after the notice to proceed is issued to allow the utilities to locate or relocate their facilities. Facilities or appurtenances that are to remain in place during construction shall be accounted for and protected by the Contractor's work procedures. Utility location and relocation shall be made in accordance with 7 CSR Division 10, Chapter 3, Utility Location and Relocation.

**Add Section 105.7.7**

**105.7.7** The Contractor shall make suitable and timely verbal and written requests to all utility locating agencies, all railroad and utility owners, all pipe owners, and other parties affected, and endeavor to have all necessary locates and adjustments of public or private utility fixtures, pipe lines, and other appurtenances within or adjacent to the limits of construction, made as soon as practicable. One (1) copy of all requests shall be submitted to the Engineer.

**Delete Sec. 105.8 thru Sec. 105.8.2 and substitute the following:**

**105.8 Construction Stakes, Lines and Grades.** The Engineer will set initial field control consisting of bench marks and control monuments.

**105.8.1** The Contractor shall be responsible for the preservation of all bench marks and control monuments, and if any of these bench marks or control monuments are carelessly or willfully destroyed or disturbed, the cost of replacing them may be charged to the Contractor.

**105.8.2** These bench marks and control monuments will constitute the initial field control by and in accordance with which the Contractor shall establish all other necessary controls and perform the work in the correct position to correspond to the information shown on the plans and given by the Engineer during the progress of the work. Elevations shown on the drawings and referred to in the specifications are based on the bench marks shown.

**105.8.3** The Contractor shall employ competent personnel for making position, gradient and alignment determinations and measurements.

**Delete Sec. 105.10.2 and substitute the following:**

**105.10.2** Inspections and job control tests will generally be made by the Engineer on the following items of work. It shall be the responsibility of the Contractor to notify the Engineer by 1:00 P.M. of the day preceding any operation which affects these items.

- Initial Layout
- Removal of Existing Structure
- Pile Driving
- Footing Excavation
- Reinforcing Steel Placement
- All Concrete Operations
- All Asphalt Operations
- Girder Erection
- Requests for Compaction Testing
- All Base Rock Operations
- All Earthwork Operations
- All Roadway Surfacing Operations
- Post-Tensioning Material Placement
- Post-Tensioning Stressing
- Cutting of Tendon Ends
- Grouting of Stressing Pockets

If any operation which affects the above mentioned items is to be performed on a Monday, notification must be made to the Engineer by 1:00 P.M. of the preceding Friday. The lack

of supervision or inspection by the Engineer shall not relieve the Contractor of the responsibility to construct the project according to the plans and specifications. Any work performed or materials used without authorization by the Engineer may be ordered removed and replaced at the Contractor's expense.

**Delete Sec. 105.11.2 and substitute the following:**

**105.11.2** All changes in the work or departures from the plans, will be considered unauthorized, and the Engineer may order such work removed and replaced at the expense of the Contractor unless, before proceeding with the work, the Contractor has a copy of an Order Record signed by the Engineer, or a Change Order signed by all parties whose signatures are provided for, except the Federal Engineer. These forms will contain complete detailed instructions regarding the proposed changes. Any departure from the instructions contained in such written order shall be considered unauthorized.

**Delete Sec. 105.11.3 and substitute the following:**

**105.11.3** All construction and materials which have been rejected or declared unsatisfactory shall be remedied or removed and replaced in an acceptable manner by the Contractor at his expense. All expense incurred by the Engineer due to corrections or removal and replacement of construction and materials shall be born by the Contractor, and will be deducted from any payment which is or may become due the Contractor. Upon failure of the Contractor to remedy or remove and properly dispose of rejected materials or work, or to replace them immediately after receiving written notice from the Engineer, the Engineer may employ labor to rectify the work, and the cost of rectification will be deducted from any payment due or which may become due the Contractor.

**Delete Sec. 105.16.5 and Sec. 105.16.6 and substitute the following:**

**105.16.6** If the claim is against the Owner, the notice of claim shall be personally delivered or sent by certified mail to the Owner. If the claim is against the Contractor, the notice of the claim will be personally delivered or sent by certified mail to the Contractor at the address shown under the signature on the proposal. If the claim is against an assignee, notice of the claim will be personally delivered or sent by certified mail to the assignee at the address shown on the accepted notice of assignment. The party against whom a claim is filed shall file any counter claims within sixty (60) days after receipt of such notice. All notices of claims shall contain an itemized statement showing completely and fully the items and amounts forming the basis of the claim.

**SECTION 106 - CONTROL OF MATERIAL**

**Add Sec. 106.1.4.1:**

**106.1.4.1** Unless otherwise specified, all materials shall be subject to visual inspection and job control tests, as determined by the Engineer, and shall be certified by the material supplier that the material supplied conforms to the requirements of these specifications. All

certifications shall make reference to the specific project, and shall contain the supplier's name and address.

**Delete Sec. 106.2.2 and substitute the following:**

**106.2.2 Contractor Furnished Sources.** If sources of material are not designated in the plans or described in the contrast, or if the Contractor desires to use material from sources other than those designated, the Contractor shall acquire the necessary rights to take materials from the sources and shall pay all costs related thereto, including any which may result from testing of samples by an approved laboratory as required by the Engineer and for an increase in length of haul. All costs of exploring, meeting environmental requirements and developing such other sources shall be borne by the Contractor. The use of material from other than designated sources which have not had prior approval of the Engineer shall be used at the Contractor's risk and may be considered as unacceptable and unauthorized and, if so considered, will not be paid for. Where practicable, borrow areas, gravel pits, and quarry sites shall be located so that they will not be plainly visible from the state highway or county road.

**Delete Sec. 106.3 and substitute the following:**

**106.3 Samples, Tests, and Cited Specifications.** The Contractor shall submit certifications and substantiating test reports, furnished by the supplier or fabricator, certifying that material and manufacturing procedures conform to the specifications. There shall be no direct charge to the Owner for materials taken as samples, either for field tests or for laboratory tests. If a specification of a recognized national standard agency (ASTM, AASHTO, AWWA, AWS, etc.) is designated, the material may, unless otherwise specified, meet either the designated specification or the latest revision thereof in effect at the time of letting of the contract. Unless otherwise specified, all sampling and testing required by the specifications shall be performed by the supplier or fabricator at no cost to the Owner in accordance with the methods specified in the contract or in accordance with the latest methods in effect at the time of letting of the contact, as prescribed by the national standard agency, and the results shall be signed, sealed and stamped according to laws related to professional Engineers. If appropriate methods have not been so prescribed, tests shall be performed in a manner determined by the Engineer.

**Delete Sec. 106.8 and substitute the following:**

**106.8 Material Furnished by the Owner.** If any material is to be furnished by the Owner, special provisions designating such materials and their locations will be included in the proposal. The cost of handling and placing all materials shall be considered as included in the contract price for the item in connection with which they are used. The Contractor will be responsible for all material provided to him, and deductions will be made from any monies due him to make good any shortages and deficiencies, from any cause whatsoever, and for any damage which may occur, and for any demurrage charges.

**SECTION 107 – LEGAL RELATIONS AND RESPONSIBILITY TO THE PUBLIC**

**Delete Sec. 107.13 and substitute the following:**

**107.13 Insurance Requirements.** The Contractor shall procure and maintain at its own expense, until acceptance by the Engineer, liability insurance for all damages and losses imposed by law and assumed under the contract, of the kinds and in the amounts specified in Secs 107.13.1 through 107.13.3. Before the Contractor commences the work, the Contractor shall require the insurance company or companies to furnish to the Engineer evidence of such insurance showing compliance with these specifications. All insurance required in Sec 107.13 shall be occurrence policies in a form acceptable to the Engineer, and shall remain in form until all work required to be performed under the terms of the contract is satisfactorily completed as evidenced by its formal acceptance by the Engineer. Each policy or its declaration pages shall provide that the policy shall not materially be changed or canceled until the Engineer has been given at least 30 days advance notice in writing. If any policy is canceled before the contract work is complete, a satisfactory replacement policy must be in force, with notice and evidence of insurance submitted to the Engineer, prior to the effective date of cancellation of the former policy. All evidence of insurance and notices shall be submitted to the Engineer. Upon request, the Contractor shall promptly furnish the Engineer with a complete copy of the policy. Failure to furnish evidence of proper insurance, or complete insurance policies when requested, will result in the temporary suspension of work as provided in Sec 108.6, and may result in order claims or actions for breach of contract or otherwise, as may be recognized at law or in equity.

**Delete Sec. 107.13.2.3 and substitute the following:**

**107.13.2.3 Additional Insureds.** Each policy of commercial general liability insurance shall name the Owner, Engineer and its members, agents and employees as additional insureds. Each commercial general liability insurance policy shall also contain a separation of insured conditions. The insurance afforded by the Contractor shall be primary insurance.

**Delete Sec. 107.15 and substitute the following:**

**107.15 Personal Liability of Public Officials.** There shall be no personal liability upon the public officials, or any member, employee or agent of the Owner in carrying out any of the provisions of the contract or in exercising any power or authority granted to them, it being understood that in such matters they acted as agents and representatives of the Owner with official and public duty doctrine immunity. If any provision of the contract appears to impose a duty on such an individual, the duty remains exclusively that of the Owner and is not a personal duty or obligation of the individual.

**SECTION 108 - PROSECUTION AND PROGRESS**

**Delete Sec. 108.1.1 and substitute the following:**

**108.1.1** The Contractor shall not sublet, sell, transfer, assign, or otherwise dispose of the contract or contracts or any portion thereof, or of his right, title, or interest therein, without written consent of the Engineer. Requests for permission to sublet, assign, or otherwise dispose of any portion of the contract shall be in writing and shall be accompanied by evidence that the organization which will perform the work is particularly experienced and equipped for such work. In case such consent is given, the Contractor will be permitted to sublet a portion thereof, but shall perform with his own organization work amounting to not less than forty percent (40%) of the total contract cost, except that any items designated by the Engineer as specialty items may be performed by subcontract and the contract value of any such specialty items so performed by subcontract may be deducted from the total contract cost before computing the amount of work required to be performed by the Contractor with his own organization. The subcontractor shall not sublet, sell, transfer, assign, or otherwise dispose of the subcontract. Consent to a subcontract shall constitute the Owner's endorsement of the qualifications of the subcontractor.

**Delete Sec. 108.4 and substitute the following:**

**108.4 Progress Schedules.** The Contractor shall, if requested by the Engineer, submit a progress schedule for review and approval. The progress schedule shall be submitted to the Engineer within three (3) days of the receipt of the request. The progress schedule shall be used to establish the construction operations and to monitor the progress of the work although the Engineer's determination of the then major operation or controlling item of work shall always prevail. The progress schedule shall be in the form specified in Sec 108.4.1, unless the contract contains a different requirement. The progress schedule shall be based on the number of working days, calendar days or other increments as set forth in the contract that the Contractor expects to require in completing the project recognizing the capabilities of labor, equipment, arrangements for materials, mobilization, shop drawing preparation and approvals, and other relevant items.

**Delete Sec. 108.4.2 and substitute the following:**

**108.4.2 Preparation of Initial Schedule.** The Contractor shall, if requested by the Engineer, complete development of the initial activities schedule chart and written narrative and present a copy to the Engineer at least seven (7) days prior to the pre-construction conference.

**Delete Sec. 108.7.2.2 and substitute the following:**

**108.7.2.2** The count of working days will start on the date the Contractor starts construction operations, or the authorization date in the Notice to Proceed, whichever is earlier. The Engineer will be the judge of the number of working days to be charged under the contract. In computing the working days charged against the Contractor in the execution of the work, allowance will be made for days that are not working days and for days during which work is suspended with the written approval of the Engineer. The Engineer may make allowance for working days lost due to causes he deems justified for the elimination of the count of working days. No allowance will be made for delay or

suspension of the prosecution of the work due to fault of the Contractor. On or about the first of each month, the Engineer will give the Contractor written notice of the number of working days charged to the contract for the preceding time period. Any objection by the Contractor to the number of working days so charged shall be made in writing within five (5) days, setting forth his objections and specifying the reasons therefore, or those objections shall be forever waived and may not constitute the basis for an excusable or compensable delay.

## **SECTION 109 - MEASUREMENT AND PAYMENT**

**Delete Sec. 109.1 and substitute the following:**

**109.1 Measurement of Quantities.** Unless otherwise specified hereinafter, all work performed under the contract will be paid for on contract quantity basis as set forth in these specifications. When the quantity of any item that is to be paid for on a contract quantity basis is found to include errors, or when an authorized revision of the plan is made, the quantity will be corrected before making final payment. The method of measurement and computations to be used in determination of quantities of material furnished and of work performed under the contract will be those methods generally recognized as conforming to good engineering practice.

**Add Sec. 109.5.9:**

**109.5.9** The Contractor shall not begin any work for which price payments are not provided in the contract without first bringing the matter to the attention of the Engineer, and no bills or charges for extra or force account work will be allowed except for that ordered in writing and approved by the Engineer.

**Delete Sec 109.6 and substitute the following:**

**109.6 Method of Payment.** Payment to the Contractor for furnishing all material and performing all work under the contract shall be made by check.

**Delete Sec. 109.7 in its entirety and substitute the following:**

### **109.7 Partial Payments**

**109.7.1** The engineer will make semi-monthly payment estimates in writing for the material in place and the work performed during the semi-monthly interval and the value thereof at the contract bid prices. For partially complete items, the proper percentage with relation to completion will be allowed.

**109.7.2** The contractor may request in any payment estimate that the engineer include the value of any non-perishable material that will be finally incorporated in the completed work. The engineer shall make the final decision whether to allow a partial payment.

Provisions shall be in accordance with Sec. 109.7.2 of the *Missouri Standard Specifications for Highway Construction*.

**109.7.3** From the total amount of work items of each estimate, there will be deducted five (5) percent. The retained percentage will be released as provided in Sec. 109.9. The net amount due on the estimate will be certified to the Owner for payment.

**109.7.4** Payment may be withheld or nullified in whole or part to such extent as may be necessary to protect the Owner from loss on account of:

- a. Failure to properly submit material certifications and substantiating test reports required under Sec. 106.1.4.1 and Sec. 106.3.
- b. Failure to properly submit certified copies of labor payrolls required under Sec. 110.
- c. Defective work not remedied.
- d. Failure of the Contractor to properly make payment to suppliers or subcontractors for material and/or labor (RSMo 34.057)
- e. A reasonable doubt that the contract can be completed for the balance then unpaid.
- f. Damage to another Contractor.

**Delete Sec. 109.9.1 and substitute the following:**

**109.9.1 Withholding of Retained Percentage** Prior to any release of retained percentage, the Contractor shall file with the Owner the following:

- a. An affidavit, to the effect that all payments have been made and all claims have been released for all materials, labor, and other items covered by the contract bond;
- b. Written consent of the surety to such payment;
- c. Certification regarding work performed by and payments made to Disadvantaged Business Enterprises (DBE's);
- d. Lien Waivers signed by each supplier furnishing materials to the project and/or each subcontractor providing services/materials for the project releasing all claims to said materials and services;
- e. The Contractor and all subcontractors shall file an affidavit stating that each has fully complied with the provisions and requirements of the Prevailing Wage Law;

f. Any other documents which may be required by the contract, or the Engineer.

**Add Sec. 109.9.1.3:**

**109.9.1.3** When the work has been completed and certified by the Owner, a final estimate will be executed and submitted, which will provide payment to the Contractor for the entire sum due him as set forth in these specifications, including the amount previously retained by the Owner. All prior partial estimates and payments shall be subject to correction by the Owner in this final estimate and payment.

**SECTION 110 - STATE AND FEDERAL WAGE RATES AND OTHER REQUIREMENTS**

**Add Sec. 110.5:**

**110.5** The Contractor and all subcontractors shall maintain books, accounts, ledgers, invoices, drafts, documents, pages and other business records pertaining to the performance of the contract with such materials available at the Contractor's field or permanent business offices at all reasonable times during the performance of the contract and for four (4) years from the date of final payment under the contract, for inspection by authorized representatives.

**Add Sec. 110.6:**

**110.6** The Contractor and each subcontractor shall be required to submit to the Engineer one certified copy of labor payrolls and a weekly statement of compliance (Form WH-347) for each week that work is in progress, within seven (7) days of the payment date of the payroll. If work is temporarily suspended, the last payroll shall be marked appropriately to note that it will be the last payroll until work is resumed.

**Add Sec. 110.7:**

**110.7** Payrolls to be submitted shall be checked for compliance with the contract requirements and will be retained by the Owner for a period of three (3) years following final audit, during which time they will be open to inspection.

**Add Sec. 110.8:**

**110.8** The Contractor shall be responsible for the submittal of payrolls and certifications for all subcontractors.

**Add Sec. 110.9:**

**110.9** The Owner may check payrolls with the following checks, however, it will still be the Contractor's responsibility to ensure proper labor compliance:

- a. The employee's full name as shown on his social security card, his address and social security number shall be entered on each payroll.
- b. Check the payroll for correct employee classification.
- c. Check the payroll for correct hourly wage and, if applicable, the correct overtime hourly rate.
- d. Check the daily and weekly hours worked in each classification including actual overtime hours worked. (Not adjusted hours)
- e. All deductions are listed in the net wage shown. The Form WH-347 is to be used if fringe benefits are paid into established programs. However, if fringe benefits are paid in cash to the employee, the amount shall be indicated on the payroll.
- f. To assure that the payrolls are arithmetically correct, approximately ten percent (10%) of the extensions on the first three (3) payrolls shall be checked. The Contractor will be advised of any violations noted on the labor payroll. All the errors will be corrected by means of a supplementary payroll.
- g. All checking by the Owner will be made in red pencil and initialed by the checker.
- h. Final payroll will be marked "Final" or "Last Payroll".
- i. A record of all payrolls will be maintained by the Owner.

**Add Sec. 110.10:**

**110.10** The contracts for construction projects require that certain applicable information be displayed in a conspicuous place within the project limits for the duration of the contract. The following is a list of required information to be posted both on the project and in the Owner's office:

- a. In the Owner's office:
  - 1. Missouri Equal Employment Opportunity Notice
  - 2. PR-1022, Title 18, Section 1020, Notice on False Statements
- b. On the Projects:
  - 1. State and Federal Wage Rates Notice
  - 2. Federal Equal Employment Opportunity Notice (English and Spanish version)
  - 3. PR-1022, Title 18, Section 1020, Notice on False Statements
  - 4. Form FHWA-1495, and FHWA-1495A, Wage Rate Information (Post with Federal Wage Rates, if applicable)

5. Contractor's and Subcontractor's EEO Policy Statements and name, address, and telephone number of designated EEO Officers
6. Notice to Labor Unions of Contractor's commitment to EEO (if applicable)
7. Notice requesting referral of minorities by present employees

**Add Sec. 110.11:**

**110.11** The Owner's personnel will generally conduct one wage rate interview on each project every month. Labor interviews are not required on railroad and other utility adjustments. The interviewer will determine the employee's name, the employer's name, the classification of the employee, the actual wage paid, and the posted wage.

## TECHNICAL SPECIFICATIONS

The Technical Specifications for the Cole County shall consist of the currently corrected 1999 version of the Missouri Standard Specifications for Highway Construction, Sections 201-1072, except as modified or contradicted herein.

### **SECTION 201 - CLEARING AND GRUBBING**

**Delete Sec. 201.2.4 and substitute the following:**

**201.2.4** Except in national forest areas, all timber not designated to remain shall be removed and properly disposed of by the Contractor unless the landowner indicates that they want the wood. In this case, the Contractor shall remove the stump for disposal and place the tree off of the right-of-way using care to limit damage to the tree and the landowner's property. Low hanging and unsound or unsightly branches on trees or shrubs designated to remain shall be removed as directed by the Engineer and in accordance with good tree surgery practices.

**Delete Sec. 201.3.1 through 201.3.4, and substitute the following:**

**201.3.1** The work provided herein will be measured for payment at the contract unit price.

### **SECTION 202.10 REMOVAL OF BRIDGES**

**Delete Sec. 202.13 Basis of Payment.** Payment for the removal and disposal of bridges will be made at the contract unit prices. If no pay item for removal of disposal of bridges is included in the contract, payment will be considered incidental to the work and no direct payment will be made.

### **SECTION 203 - ROADWAY AND DRAINAGE EXCAVATION, EMBANKMENT, AND COMPACTION**

**Delete Sec. 203.1.1**

**Delete Sec. 203.1.2**

**Delete Sec. 203.1.2.1**

**Delete Sec. 203.1.3**

**Delete Sec. 203.1.4**

**Delete Sec. 203.2.5.2 - Undergrading, and substitute the following:**

**203.2.5.2 Undergrading in Rock Cut.** In rock cut areas, excavation shall be carried to twelve (12) inches below subgrade to a minimum distance of two (2) feet behind back of curb or shoulder. Backfilling of undergraded cut areas shall be with a drainable material with top surface choked with fines for proper subgrade preparation.

Whenever possible, this material shall be from project excavation. Where authorized, an open-graded drainable crushed limestone shall be brought in. Undrained pockets shall not be left in the surface of the rock.

**Delete Sec. 203.3.8 through 203.3.8.2 - Compacting in Cuts, and substitute the following:**

**203.3.8 Subgrade Stabilization.** Cut compaction shall be performed after removal of the roadway excavation material to the required section. The compactive effort shall consist of distributing all equipment movements over the entire cut area and of at least three complete coverages with a tamping-type roller over the entire area to be compacted. The tamping-type roller shall have tampers or feet projecting not less than six (6) inches from the surface of the drum and shall have a minimum load on each tamper of 250 pounds per square inch of tamping area. Compactive effort shall be continued, if necessary, until the tamping feet penetrate not more than two (2) inches into the layer being compacted. Continuous leveling and manipulating will be required during compacting operations and the moisture content adjusted as is necessary, in the judgement of the Engineer, to permit proper consolidation.

**203.3.8.1** Pockets of unsuitable material encountered in cut areas will be removed and re-compacted as outlined above. If the desired compaction cannot be obtained, the material will be removed and replaced with crushed stone as directed by the Engineer.

**203.3.8.2** The finished cut area shall be firm and unyielding. The Engineer, at his option, may proof roll the finished cut area with a fully loaded tandem dump truck. In the opinion of the Engineer, additional compaction will be required if there is appreciable movement or rutting of the subgrade. The Engineer may require the material to loosened and re-compacted.

**Delete Sec. 203.3.9 - Field Laboratory.**

**Add Sec. 203.4.3 - Compaction of Embankments not Constructed with Density or Moisture and Density Control, by adding the following sentence to the end of the paragraph:**

**203.4.3** The finished embankment shall be firm and unyielding. The Engineer, at his option, may proof roll the finished embankment with a fully loaded tandem dump truck. In the opinion of the Engineer, additional compaction will be required if there is appreciable movement or rutting of the subgrade. The Engineer may require the material to loosened and re-compacted.

**Delete Sec. 203.6 - Method of Measurement in its entirety, and substitute the following:**

**203.6 - Method of Measurement.**

**203.6.1 Excavation and Compacted Embankment.** The Work provided herein will not be measured for payment, unless a change is made to the plans as bid. The accepted excavation and compacted embankment, shall be included in the contract unit price for Sec. 207 - Linear Grading.

**203.6.2 Borrow.** No measurement of borrow excavation will be made. All costs of supplying borrow material to the Project site shall be included in the contract unit price for Sec. 207 – Linear Grading.

**203.6.3 Excavation for Subgrade Stabilization.** No measurement for payment will be made.

**203.6.4 Excavation for Structures, Etc.** No measurement for payment will be made for excavation for structures, pipes, reinforced concrete boxes, or paved ditches. This shall include the excavation of any material, whether rock or earth, suitable or unsuitable, regardless of whether shown on the plans for encountered during construction, and the suitable backfill required thereof. Excavation and suitable backfill will be considered incidental to the work.

**Delete Sec. 203.7 - Basis of Payment in its entirety, and substitute the following:**

**203.7 - Basis of Payment.**

**203.7.1 Excavation and Compacted Embankment.** The accepted excavation and compacted embankment, shall be included in the contract unit price for Sec. 207 - Linear Grading.

**203.7.2 Crushed Stone for Subgrade Stabilization.** Payment for crushed stone for subgrade stabilization under roadway shall be per ton of material provided, based on tickets submitted to the County at the time the work is done. Payment shall be at the unit price bid which shall include all labor, materials, tools and equipment necessary to stabilize the area including removal of unsuitable material, disposal of the material off-site and subgrade preparation. There shall be no direct payment for subgrade stabilization under structures or pipes.

**203.7.3** No direct payment will be made for water required in compaction work. Any costs involved in reducing the moisture content in soils will be at the expense of the Contractor.

## **SECTION 204 - EMBANKMENT CONTROL**

Delete entire section

## **SECTION 205 - OVERHAUL**

Delete entire section

## **SECTION 206 - EXCAVATION FOR STRUCTURES**

Delete entire section

## **SECTION 207 - LINEAR GRADING**

**Delete Sec. 207.1.1 & 207.1.2, and substitute the following:**

**207.1.1 Linear Grading.** Linear Grading shall consist of grading where it is necessary to excavate and haul material to bring the roadway to the grade and designated cross section and may involve work on high banks and side hills. This may also require additional borrow that may be required from off site areas and shall be considered incidental to the project. It will be the Contractor's responsibility to review the plans and to determine if off site borrow is needed.

**Delete Sec. 207.1.3**

**Delete Sec. 207.2.4, and substitute the following:**

**207.2.4** Subgrade shall be compacted in accordance with Sec. 203.

**Delete Sec. 207.3 and 207.3.1, and substitute the following:**

**207.3 Method of Measurement.** Measurement of Linear Grading will be to the nearest 1/10 station.

**Delete Sec. 207.3.2**

## **SECTION 208 - INTERCEPTION DITCH**

Delete entire section.

## **SECTION 209 - SUBGRADE PREPARATION**

**Delete Sec. 209.3.1, and substitute the following:**

**209.3.1** The subgrades shall be checked after rolling and, if not at the proper elevation at all points, sufficient material shall be removed or added and compacted to bring all

portions of the subgrade to the required elevation and density. The moisture content of the top six (6) inches of the finished subgrade at the time the base is placed, or at the time the pavement is placed if no base is provided under the pavement, shall not be less than the minimum specified for compacting in Sec 203. If the moisture content has not been maintained, the subgrade shall be scarified, wet to the required moisture content, and compacted. A roughly compensating maximum deviation of 2 inch, plus or minus, from the required elevation will be permitted on the surface of the finished subgrade.

**Delete Sec. 209.3.3 - Subgrade Planer.**

## **SECTION 210 - SUBGRADE COMPACTION**

Delete the entire section

## **SECTION 211 - SUBGRADE SCARIFYING**

**Delete Sec. 211.1 - Description, and replace with the following:**

**211.1 Description.** This work shall consist of loosening the surface of the existing roadbed to a minimum depth of six (6) inches prior to the placement of the subgrade aggregate and removing all rocks larger than six (6) inches. All areas of the existing roadbed shall be scarified. This work shall also include the mechanical incorporation and compacting subgrade aggregate into the top portion of the roadbed in accordance with Sec. 216.

**Delete Sec. 211.2 - Construction Requirements, and replace with the following:**

### **211.2 Construction Requirements.**

**211.2.1 Existing Roadbed.** The Contractor shall perform all work necessary to loosen the surface of the existing roadbed over its specified width to a minimum depth of six (6) inches below the finished grading section, and remove all rocks larger than six (6) inches. After all the oversize material has been removed, the roadbed shall be brought back to a satisfactory grade and cross section by the addition of extra material, if needed without rocks that exceed four (4) inches.

**211.2.2 Subgrade Aggregate Incorporation.** The Contractor shall mechanically incorporate and compact the subgrade aggregate into the top portion in accordance with Sec. 216.

## **SECTION 212 - SUBGRADING AND SHOULDERING**

Delete entire section

**SECTION 214 - WATER**

Delete entire section

**SECTION 216 - SUBGRADE AGGREGATE**

**216.1 Description.** This work shall consist of furnishing and placing one or more courses of aggregate into the subgrade during its preparation in accordance with these specifications and in conformity with the lines, grades, thickness, and typical cross-section shown on the plans or established by the Engineer. The type of aggregate to be used will be specified in the contract.

**216.2 Materials.** Aggregate for subgrade aggregate shall be composed of durable particles of rock. When tested in accordance with AASHTO T 96, the percentage of wear shall not exceed 60. The percentage of deleterious substances shall exceed the following values and the sum of percentages of all deleterious substances shall not exceed 12 percent.

	<u>Percent by Weight</u>
Deleterious Rock or Shale.....	12.0
Mud Balls.....	5.0
Other Foreign Material.....	2.0

**216.2.1** The aggregate shall comply with the requirements:

Per Passing by Weight			
Sieve Sizes			
2"	1-1/8"	1"	3/4"
100	100	100	0-10

**216.3 Construction Requirements.**

**216.3.1 Mixing and Placing.** After the designated quantity of subgrade aggregate has been distributed and spread uniformly over the prepared subgrade, it shall be incorporated into the upper six (6) or more inches of the roadbed by use of a blade, tiller scarifier or disk until a uniform mixture of subgrade material and roadbed soil is attained. The final product should have evidence of the underlying soil being uniformly mixed with the aggregate on the finished surface.

**216.3.2 Compaction.** The mixture shall be compacted by not less than three (3) complete coverages with a tamping-type roller and rolling shall be continued until there is no visible evidence of further consolidation. The tamping roller shall have a minimum load on each tamper of 250 pounds per square inch of tamping area. Water shall be added to or removed from the mixture as necessary, in the judgement of the Engineer, to permit proper consolidation. Shaping and compaction shall be continued until a true uniform surface of proper cross section is obtained.

**216.3.3** The compacted mixture of aggregate subgrade material and roadbed soil shall be maintained until the work has been accepted. Weak or soft spots which develop at any time in the compacted surface prior to acceptance shall be repaired with suitable material at the Contractor's expense. The finished surface shall be firm and unyielding. The roadbed shall be tested for density prior to final acceptance by the County with a fully loaded tandem dump truck. In the opinion of the Engineer, repairs with acceptable materials and additional compaction will be required if there is appreciable movement or rutting of the aggregate at no additional cost to the Owner.

**216.4 Method of Measurement and Payment.** Measurement and payment will be by the ton in place and will be considered for all equipment, labor, material or other construction involved in completing this work. Material tickets will be required to verify all tonnage. No payment will be made for water used in performing this work. Any costs involved in reducing the moisture content will be at the expense of the Contractor.

### **SECTION 304 – AGGREGATE BASE COURSE**

**Delete Sec 304.3.5.2**

**Delete Sec 304.3.5.3, and substitute the following:**

**304.3.5.3** Shaping and compacting shall be performed until a true, even, and uniform surface of proper grade, cross section, and density is obtained. Aggregate shall be compacted by not less than three complete coverages with a self-propelled smooth double wheel roller weighing not less than 10 tons. Rolling shall be continued until there is no visible evidence of further consolidation and the base is firm and unyielding. During shaping and compacting operations, the moisture content of the base shall be maintained at the level necessary for compaction by wetting or drying as required. Final rolling shall not leave appreciable ridges in the base material.

**Delete Sec 304.3.6 – Maintenance, and substitute the following:**

**304.3.6 Maintenance.** The Contractor shall maintain the base by wetting or drying, blading, and rolling in a manner satisfactorily to the Engineer until final acceptance. This maintenance, including necessary water, shall be entirely at the Contractor's expense. The Contractor shall maintain the required density and surface condition of any portion of the completed base until final acceptance.

**Delete Sec 304.4 – Method of Measurement in its entirety, and substitute the following:**

**304.4 Method of Measurement.**

**304.4.1 Measurement of Aggregate Base Course by Area.** Measurement of aggregate base course complete in place will be made to the nearest square yard. Final

measurement of the completed aggregate base course will not be made except for authorized changes during the construction, or where appreciable errors are found in the contract quantity. The revision or correction will be computed and added to or deducted from the contract quantity.

### **SECTION 308 PORTLAND CEMENT-TREATED BASE**

Delete entire section

### **SECTION 309 - PORTLAND CEMENT CONCRETE BASE**

**Delete Sec. 309.6 - Method of Measurement, and substitute the following:**

**309.6 Method of Measurement.** Pavement areas will be measured and computed to the 1/10th of a square yard.

**Delete Sec. 309.7 - Basis of Payment, except Subsection 309.7.4**

### **SECTION 310 - AGGREGATE SURFACE**

**Delete the entire section, and substitute the following:**

**310.1 Description.** This work shall consist of furnishing and placing surfacing in the quantity shown in the plans, or as directed by the Engineer.

**310.2 Materials.** All material shall conform to Division 1000, Material Details, and specifically to Sec 1006. The type and gradation of the surfacing material to be used will be specified in the contract.

#### **310.3 Construction Requirements.**

**310.3.1** The Contractor shall furnish, haul and spread surfacing material on the subgrade aggregate at the designated rate. The rate of application and type of material may be varied at the discretion of the Engineer, depending on the location and other factors. The Contractor shall be responsible for the uniform loading and distribution of the required quantity of material. The subgrade and subgrade aggregate shall be prepared as specified in appropriate sections of the specifications. Any work done in reshaping the subgrade and subgrade aggregate before placing the surfacing material shall be at the Contractor's expense. When it is determined by the Engineer to be to the County's advantage, hauling may be done over surfacing material previously spread; otherwise, all hauling shall be over the subgrade aggregate.

**310.3.2** The material shall be spread to a uniform thickness over the subgrade aggregate within 24 hours after being deposited on the roadbed, unless at the discretion of the Engineer, the condition of the subgrade aggregate is such that additional time should

elapse. Surplus material shall be left on one shoulder in a neat and symmetrical windrow, leaving openings for all approaches and for the drainage of low points.

**310.3.3** After being compacted under traffic, the material shall be shaped and ruts filled by blading the roadbed as frequently as is necessary to prevent cutting through the surfacing material into the subgrade aggregate. Irregularities which develop and which are not filled by blading shall be filled by adding more material. The material shall be shaped until it conforms to the cross-section indicated in the plans, and it is free from ruts and waves. Maintenance of the surface shall continue until acceptance is made.

**310.3.4** The compacted mixture of aggregate surface, aggregate subgrade material and roadbed soil shall be maintained until the work has been accepted. Weak or soft spots which develop at any time in the compacted surface prior to acceptance shall be repaired with suitable material at the Contractor's expense. The finished surface shall be firm and unyielding. The roadbed shall be tested for density prior to final acceptance by the County with a fully loaded tandem dump truck. In the opinion of the Engineer, repairs with acceptable materials and additional compaction will be required if there is appreciable movement or rutting of the aggregate at no additional cost to the Owner.

**310.4 Method of Measurement and Basis of Payment.** Measurement and payment will be by the ton in place. Material tickets will be required to verify the tonnage. Payment shall be at the unit price bid which shall include all labor, materials, tools and equipment necessary to place and maintain the surfacing material including removal and replacement of areas that have movement or rutting occur. No payment will be made for water used in performing the work.

### **SECTION 311 - PROCESSING AGGREGATE SURFACE**

Delete entire section

### **SECTION 402 - PLANT MIX BITUMINOUS SURFACE LEVELING**

Delete entire section

### **SECTION 403 - ASPHALTIC CONCRETE PAVEMENT**

Delete entire section

### **SECTION 405 - ROAD MIX BITUMINOUS PAVEMENT**

Delete entire section

### **SECTION 407 - TACK COAT**

**Delete Sec. 407.5 through 407.6.1, and substitute the following:**

**407.5** The work provided herein will not be measured for payment. This work will be considered subsidiary to the plant mix bituminous pavement or base course.

**Delete Sec. 408 - Prime Coat**

## **SECTION 501 - CONCRETE**

**Delete Sec. 501.2.2 - Mix Design, and substitute the following:**

**501.2.2 Mix Design.** Actual mix designs shall be prepared by an approved testing laboratory and submitted to the Engineer for approval.

Submittal shall include source and properties of all aggregate, source of cement, proportions used, slump, air content and results of breaks of five (5) test cylinders. Cylinders shall be broken as follows:

Two (2) at Seven (7) days  
Three (3) at Twenty-Eight (28) days

Prior to starting project, Contractor shall obtain in the presence of the Engineer, representative samples of cement, fine and coarse aggregates for test. The samples of material shall be of the size designated by the Engineer and shall be submitted to an approved laboratory for testing. The Contractor shall submit for the Engineer's approval each Job-Mix formula. The maximum time a Job-Mix will be used will be two (2) construction seasons.

All concrete for sidewalks, drop inlets, manholes, junction boxes, and all other incidental concrete shall be Class B. All concrete for curb and gutter, drive approaches, and concrete pavement shall be Class B-1.

## **SECTION 502 - PORTLAND CEMENT CONCRETE PAVEMENT**

**Delete Sec. 502.3.9 Field Laboratory**

**Delete Sec. 502.10 - Final Strike Off**

**Delete Sec. 502.10.5 - Station Numbers**

**Delete Sec. 502.14 through 502.14.6.6**

**Delete Sec. 502.15 - Opening to Traffic, and substitute the following:**

**502.15 Opening to Traffic.** The pavement shall not be opened to any traffic until the concrete has attained a minimum compressive strength of 3000 pounds per square inch.

**Delete Sec. 502.16 - Slip Form Construction and substitute the following:**

**502.16 Slip Form Construction.** At the option of the Contractor, pavement may be constructed by the use of sliding form methods.

**Delete Sec. 502.16.3 - Consolidating and Finishing Equipment**

**Delete Sec. 502.17.1 through 502.17.5**

**Delete Sec. 502.19 through 502.19.10, and substitute the following:**

**502.19 - Basis of Payment.** The accepted quantities of Portland Cement concrete pavement will be paid for at the contract unit price with no allowances for excess thickness.

### **SECTION 601 - FIELD LABORATORIES**

Delete entire section

### **SECTION 602 - MARKERS**

Delete entire section, and substitute the following:

### **SECTION 602 - U.S. PUBLIC LAND SURVEY CORNERS, PROPERTY CORNERS AND RIGHT-OF-WAY MONUMENTS**

**602.1 Description.** - It shall be the responsibility of the Contractor to protect all U.S. Land Survey Corners, Property Corners and Right-of-Way Monuments as noted on the plans. Should it be necessary to disturb any such Corner or Monument (stake, pipe, pin, stone, etc.), it shall be the responsibility of the Contractor to have such Corners/Monuments referenced prior to removal and reset after construction is complete by a Land Surveyor, registered in the State of Missouri. All U.S. Public Land Survey Corners which may be disturbed during the construction shall be referenced and restored in compliance with current regulations and standards of the Missouri Board for Architects, Professional Engineers, and Land Surveyors and the Missouri Department of Natural Resources.

**602.2 Protection of U.S. Land Survey Corners and Property Corners NOT TO BE DISTURBED.** The Contractor shall, prior to construction, verify the location of all U.S. Land Survey Corners and Property Corners which lie within or adjacent to the construction areas as noted on the plans and designated as "DO NOT DISTURB". The Contractor is responsible for protecting all such monuments during the construction period. Any such monument which is disturbed or damaged during construction shall be replaced, at the Contractor's expense, by a Land Surveyor registered in the State of Missouri.

**602.3 Protection of Road Right-of-Way Monuments.** The Contractor shall protect all Road Right-of-Way Monuments which have been established to mark road right-of-way limits and establish construction limits for the Project. Any Right-of-Way Monument which

is disturbed or damaged during construction shall be replaced, at the Contractor's expense, by a Land Surveyor registered in the State of Missouri.

**602.4 Remonumentation of U.S. Land Survey Corners and Property Corners.** The Contractor shall reference all U.S. Land Survey Corners and Property Corners designated on the plans prior to any activities in the area. Copies of the references prepared by a Land Surveyor, registered in the State of Missouri, shall be submitted to the County prior to payment. Prior to final acceptance, all U.S. Land Survey Corners and Property Corners disturbed or removed during construction shall be reset by a Land Surveyor, registered in the State of Missouri. Prior to final payment, the County will field verify all Corners have been reset.

**602.5 Basis for Payment.**

**602.5.1 Reference of U.S. Land Survey Corners and Property Corners.** The accepted quantity will be paid for at the unit price for each of the pay items included in the contract.

**602.5.2 Reset U.S. Land Survey Corners and Property Corners.** The accepted quantity will be paid for at the unit price included in the contract.

**602.5.3 Reference of Property Corners.** The accepted quantity will be paid for at the unit price for each of the pay items included in the contract

**602.5.4 Reset Property Corners.** The accepted quantity will be paid for at the unit price included in the contract.

**SECTION 604 - MISCELLANEOUS DRAINAGE**

**Delete Sec. 604.14 - Basis of Payment, and substitute the following:**

**604.14 Basis of Payment.** Drop inlets, manholes, and junction boxes to be paid for at the contract unit price. Including excavation, reinforcing steel, concrete and any incidental work connected to structure.

**SECTION 604.6 - ROOF DRAINS AND FOUNDATION DRAINS**

**604.6.1 Description.** This work shall include connecting existing downspout drains through and into the proposed curb, curb and gutter, or storm sewer facility. The location of some downspout drains may be shown on the plans, but other drains may exist that are not shown. The Contractor shall be responsible to connect all downspout drains regardless of whether they are shown on the plans.

**604.6.2 Construction Methods.** The Contractor shall exercise care in removing existing facilities so as to minimize damage to existing drains. Generally, new material of the same diameter as the existing drain shall be used.

As approved by the Owner, the removed pipe may be cleaned and re-used.

**604.6.3 No Direct Payment.** All work associated with connecting downspout drains through or into the proposed curb, curb and gutter, or storm sewer facility shall be subsidiary to the item to which it is connected. No direct payment will be made.

## **SECTION 606 – GUARDRAIL AND GUARD CABLE**

### **Add Section 606.10 - Crashworthy Guardrail Terminal**

**606.10.1 Description.** This item provides for the furnishing and installation of crashworthy guardrail end terminals as shown on the plans or directed by the engineer.

**606.10.2 Materials and Design.** Only new materials shall be used in the fabrication of the terminals. The major items of the installations shall be the best standard products of a manufacturer regularly engaged in the production of this type of end terminal and shall be of the manufacturer's latest approved design. After installation, the end terminal shall redirect traffic face side vehicle impacts within the prescribed "Performance" crash test criteria ranges.

**606.10.3 Performance.** The assembled unit shall be capable of developing full tensile strength of the standard rail system and also have redirection and end-on capabilities as per criteria identified in National Cooperative Research Report 350 and supplements thereto. The assembled unit shall contain or permit controlled penetration of the vehicle into the system in an acceptable manner for vehicles in the 1,842 to 4,410-pound (820 kg to 2000 kg) classes.

**606.10.4 Construction.** The end terminals shall be fabricated and installed in accordance with the manufacturer's approved shop drawings, recommendations and the details shown in the plans. Any end terminals damaged during the term of the contract shall be replaced immediately at the contractor's expense.

**606.10.5 Acceptance.** The contractor shall furnish a manufacturer's certification that the units furnished are identical in materials and design to those tested for performance in accordance with Sec 606.10.3 of this special provision. Shop drawings shall also be submitted for approval prior to the fabrication and installation of any units.

**606.10.5.1** The units listed below have met the performance criteria and may be used, provided satisfactory results are obtained in the field.

<b>Unit</b>	<b>Manufacturer</b>
ET-2000 (Option B)	Trinity Industries Co. 2525 Stemmons Freeway Dallas, Texas 75207
SKT 350	Road Systems, Inc. 7631 New Castle Drive

**606.10.5.2** Approval of other units may be requested by submitting the required information to the engineer. Acceptance shall be based upon proof of equivalent crash test results as described under Sec 606.10.3 of this special provision.

**606.10.6 Method of Measurement.** Measurement for the guard rail end terminal will be made by each unit assembled, installed and complete in place. If the Contractors elects to use the SKT-350, an additional 12.5 foot section of Type A Guardrail must also be installed to obtain a total length equivalent to that of the ET-2000, and additional embankment must be provided as shown on the plans. No compensation will be allowed for the additional 12.5 foot section of guardrail or for the additional embankment required for installation of the SKT-350.

**606.10.7 Basis of Payment.** The work performed and the materials furnished under this item will be paid for at the contract unit price.

## **SECTION 607 - FENCING**

**Modify Sec. 607.20 as follows:**

**607.20 - Woven Wire and/or Barbed Wire Fence.**

**Delete Sec. 607.21 - Description, and substitute the following:**

**607.21 Description.** This work shall consist of furnishing and erecting woven wire and/or barbed wire fence, complete in place, in conformity with the plans, and at locations as shown on the plans, or as established by the Engineer.

**Delete Sec. 607.22 - Materials, and substitute the following:**

**607.22 Materials.** Generally, fencing shall consist of the following materials:

**607.22.1** Steel line post (6.5') or hedge or treated wood line posts (4" dia x 7') @ 12' on centers.

**607.22.2** 4 strand, 4 point barbed wire, 12 gage.

**607.22.3** Zinc coated or aluminum coated woven wire fabric equal to or exceeding existing material.

**607.22.4** Hedge or treated wood corner posts, 7"diameter x 8'.

**607.22.5** Hedge or treated wood brace posts, 6" diameter x 8'.

**607.22.6** Hedge or treated wood brace timbers, 4" diameter x 8' or fabricated steel braces.

**607.22.7** Brace wire, #9 gage tension wire.

**607.22.8** Heavy duty tubular steel gate.

**607.22.9** All fencing shall be subject to visual inspection by the Engineer and shall meet with his approval prior to final acceptance.

**Delete Sec. 607.23.3, and substitute the following:**

**607.23.3** Posts shall be set plumb, true to line and grade. Corner post assemblies shall be set at all horizontal angle points greater than 15 degrees in the line of fence. Pull post assemblies shall be set at all vertical angle points greater than 15 degrees but not greater than 660 foot intervals.

**Delete Sec. 607.23.5, and substitute the following:**

**607.23.5** Walk gates and drive gates complete with hinges, latches braces, stops and locking devices shall be installed at locations shown on the plans. They shall be of the type and size shown on the plans.

**Delete Sec. 607.24 - Method of Measurement, and substitute the following:**

**607.24 Method of Measurement.** The contract quantity listed in the proposal shall be the basis for payment. Final measurement will not be made except for authorized changes during construction which significantly change the contract quantity or where appreciable errors are found in the contract quantity. The revision or correction will be computed and added to or deducted from the contract quantity.

**Delete Sec. 607.25.1, and substitute the following:**

**607.25.1** The accepted fence, complete in place, will be paid for at the contract unit price per linear foot which will include all materials, excavation for posts, backfilling, clearing of fence row, trenching for fabric, placing extra strands of barbed wire for depressions, and all other incidental work or material.

**Delete Sec. 607.25.3, and substitute the following:**

**607.25.3** The accepted water gates, complete in place, will be paid for at the unit price included in the contract.

## **SECTION 609 - PAVED DRAINAGE**

**Delete Sec. 609.20 - Integral Curb**

**Delete Sec. 609.30 - Asphalt Curb**

**Delete Sec. 609.40 - Drain Basin**

**Delete Sec. 609.63.3, and substitute the following:**

**609.63.3** Forms will be required. Concrete shall be consolidated and struck off to the required thickness and shape.

### **SECTION 610 - MASONRY CONSTRUCTION**

Delete entire section

### **SECTION 611 - EMBANKMENT PROTECTION**

**Delete Sec. 611.10 - Rock Fill**

**Delete Sec. 611.20 - Fully Grouted Rock Fill**

**Delete Sec. 611.34 - Method of Measurement, and substitute the following:**

**611.34 Method of Measurement.** Measurement will be made to the nearest square yard of completed rock blanket.

**Delete Sec. 611.35 - Basis of Payment, and substitute the following:**

**611.35 Basis of Payment.** Payment for placing rock blanket will be made at the contract unit price per square yard. No direct payment will be made for excavating the trench or for backfilling.

### **SECTION 612 - BARRICADES AND FLASHER SIGNS**

**Delete Sec. 612.4 - Basis of Payment, and substitute the following:**

**612.4 Basis of Payment.** The accepted quantities of temporary, movable and permanent barricades including warning signs and flashing lights will be paid for at the contract unit price.

### **SECTION 613 - PAVEMENT REPAIR**

**Delete Sec. 613.3 - Methods of Measurement, and substitute the following:**

**613.3 Method of Measurement.** Measurement for furnishing and placing Portland Cement Concrete Pavement will be made to the near 1/10 square yard.

**Delete Sec. 613.4 - Basis of Payment, and substitute the following:**

**613.4 Basis of Payment.** The accepted quantities of pavement repair will be paid for at the contract unit price.

**SECTION 614 - DRAINAGE FITTINGS**

**Delete Sec. 614.15 - Basis of Payment, and substitute the following:**

**614.15 Basis of Payment.** These items are considered subsidiary to other items, no direct pay.

**SECTION 615 - OFFICE FOR ENGINEER**

Delete entire section

**SECTION 725 - METAL PIPE AND PIPE ARCH CULVERTS**

**Delete Sec. 725.6 - Backfilling, and substitute the following:**

**725.6 Backfilling.** Metal pipe shall be laid on a four (4) inch minimum thickness of clean crushed stone, and backfilled to the full depth of the trench, with clean crushed stone meeting the following gradation:

<b><u>Sieve Size</u></b>	<b><u>Percent Passing By Weight</u></b>
3/4	90-100
3/8	20-55
#4	0-10
#10	0-10

**Delete Sec. 725.10 - Method of Measurement, and substitute the following:**

**725.10 Method of Measurement.** Measurement of corrugated metal pipe or pipe-arch complete in place including excavating and backfilling will be made to the nearest foot along geometrical centers of the pipe.

**SECTION 726 - RIGID PIPE CULVERTS, STORM BASINS, AND SEWERS**

**Delete Sec. 726.4.1.2 - Class B Bedding, and substitute the following:**

**726.4.1.2 Bedding** shall consist of a minimum of four (4) inch cushion and backfilled to the full depth of the trench, with clean crushed stone meeting the following gradation:

<u>Sieve Size</u>	<u>Percent Passing By Weight</u>
3/4	90-100
3/8	20-55
#4	0-10
#10	0-10

**Delete Sec. 726.8 - Method of Measurement, and substitute the following:**

**726.8 Method of Measurement.** Measurement of rigid pipe culvert, complete in place including excavation and backfill, will be made to the nearest foot along the geometrical center of the pipe.

**Delete Sec. 726.9 - Basis of Payment, and substitute the following:**

**726.9 Basis of Payment.** The accepted quantities of pipe complete in place including all necessary tees, bends, wyes cutting and joining new pipe to existing pipe unless otherwise specified will be paid for at the unit price.

**SECTION 727 - STRUCTURAL PLATE PIPE AND STRUCTURAL PLATE PIPE-ARCH CULVERTS**

**Delete Sec. 727.8 - Method of Measurement, and substitute the following:**

**727.8 Method of Measurement.** Measurement of structural plate pipe, complete in place including excavation and backfill will be made to the nearest foot along the geometrical center of the pipe.

**SECTION 728 - RELAID PIPE**

Delete entire section

**SECTION 729 - PLACING COUNTY-OWNED PIPE**

**Delete Sec. 729.3 THRU 729.4.2, and substitute the following:**

**729.3 Method of Measurement and Basis of Payment.** Measurement and payment for placing county-owned pipe will be at the unit bid price. Unit bid price shall include pick up of the pipe from the location as defined in Sec. 106.8.1 and delivery to the project site as well as all excavation and backfilling required for the installation of the pipe.

**SECTION 730 - POLYETHYLENE PIPE CULVERTS**

**Delete Sec. 730.3 - Excavation, and substitute the following:**

**730.3 Excavation.** The trench shall be wide enough to place and compact the backfill around the entire pipe. The trench shall be excavated to a minimum width of twice the nominal diameter of the pipe but not more than the nominal diameter plus two (2) feet. A minimum of six (6) inches shall be excavated or be available below the pipe for bedding material. In addition, soft or yielding material shall be removed and replaced with properly compacted bedding material.

**Add Sec. 730.4.1:**

**730.4.1** Bedding material (material between the bottom of the trench and the bottom of the pipe) shall consist of well-graded crushed stone placed and well compacted. All material shall be free of lumps, clods, frozen material, debris, etc. Crushed stone shall have the following gradation:

<b>Sieve Size</b>	<b>Percent Passing By Weight</b>
1-1/2	100
1	100-90
3/4	55-20
1/2	10-0
3/8	0

**Add Sec. 730.4.2:**

**730.4.2** Bedding material shall be a minimum of six (6) inches deep and shall be placed in six (6) inch maximum depth compacted lifts. The bedding material shall be leveled by hand and compacted. Compaction shall consist of using a shovel to “slice” the material to remove any voids.

**Delete Sec. 730.5 Backfilling, and substitute the following:**

**730.5 Backfilling.** Backfilling consists of placing haunch, initial backfill and final backfill material. Haunch, initial backfill and final backfill material shall meet the material, lift and compaction requirements for bedding.

**730.5.1** Haunch material (material from the top of the bedding to the midpoint of the pipe) shall be carefully placed, worked around the pipe by hand and compacted to provide uniform support.

**730.5.2** Initial backfill material (material from the haunch to at least 1 foot above the top of the pipe) shall be placed and compacted.

**730.5.3** Final backfilling shall continue to the top of the trench. Final backfilling shall be completed prior to subgrade scarifying as defined in Section 211 and placement of subgrade aggregate as defined in Section 216.

**Delete 730.6 - End Finish.**

**Delete 730.7 - Method of Measurement, and substitute the following:**

**730.7 Method of Measurement.** Measurement of polyethylene culvert pipe, complete in place including excavation and backfill will be made to the nearest foot along the geometrical center of the pipe.

**SECTION 731 - PRECAST REINFORCED CONCRETE MANHOLES AND DROP INLETS**

**Delete Sec. 731.4 - Method of Measurement, and substitute the following:**

**731.4 Method of Measurement.** Measurement of precast concrete manholes and drop inlets, complete in place including excavation and backfill will be paid for at the unit price.

**SECTION 801 - FERTILIZING**

**Delete Sec. 801.2.2, and substitute the following:**

**801.2.2** The rate of application of lime shall be required to provide at least 1,350 pounds of effective neutralizing material per acre. Except as otherwise provided in this specification, the quantity of material required to provide the specified pounds of effective neutralizing material per acre shall be determined from the producer or distributor's certification of analysis furnished by the Director of the Missouri Agriculture Station, Columbia, Missouri in accordance with the Missouri Agricultural Liming Materials Act.

**Delete Sec. 801.2.3, and substitute the following:**

**801.2.3** Fertilizer shall be a standard commercial product which, when applied at the proper rates shall supply the quantity of total nitrogen (N), available phosphoric acid ( $P_2O_5$ ) and soluble potash ( $K_2O$ ) to provide a final mixture of 13-13-13. The rate of application shall be 500 pounds per acre of 13-13-13 fertilizer. Material may be accepted on the basis of bag label analysis or supplier's certification, or on the basis of samples tested in the laboratory. For samples tested in the laboratory, tolerances in the nominal composition as shown by label or certification of 10 percent up to the maximum of two units (2% plant food) for the individual constituents, and minus 3 percent for the sum of the constituents, will be permitted. There is no limit on the plus tolerances for such samples.

**Delete Sec. 801.5**

**Delete Sec. 801.6 - Basis of Payment, and substitute the following:**

**801.6 Basis of Payment.** No direct payment will be made for liming and fertilizing, but will be considered incidental to the seeding item.

## **SECTION 802 - MULCHING**

**Delete Sec. 802.3.1, and substitute the following:**

**802.3.1** Type 1 Mulch (Vegetative) shall be applied at the rate of 1 ½ tons per acres.

**Delete Sec. 802.3.4, and substitute the following:**

**802.3.4** Type 4 Mulch (Embedded) shall be applied at the rate of 1 ½ tons per acre. The mulch roller shall be operated approximately parallel to the roadbed grade. The mulch shall be embedded in the soil a sufficient depth to prevent the loss of mulch by wind or water erosion. Excelsior blanket may be used in lieu of Type 4 Mulch at the option of the Contractor.

## **SECTION 804 - TOPSOIL**

**Delete Sec. 804.2 - Materials, and substitute the following:**

**804.2 Materials.** The top six (6) inches of backfill behind curb and gutter and lawn areas disturbed by construction will be an approved top soil before seeding and mulching begins. Existing topsoil in lawn areas can be excavated and reused so long as it meets the requirements of this section.

**804.2.1** Topsoil shall be obtained from approved sources. It shall be fertile, friable, and loamy soil of uniform quality, without admixture of subsoil material, and shall be free from materials such as hard clods, stiff clay, hardpan, partially disintegrated stone, pebbles larger than one (1) inch in diameter, and any other similar impurities. Topsoil shall be relatively free from grass, roots, weeds, and other objectionable plant material or vegetative debris undesirable or harmful to plant life or which will prevent the formation of a suitable seedbed.

**804.2.2** In areas other than behind curb and gutters or in lawn areas, existing soil can be used so long as it is conducive to vegetative growth. The seedbeds in these areas shall be prepared, limed and fertilized in accordance with Section 801. Rocks larger than three (3) inch in diameter shall be picked and removed from the site.

**Delete 804.4 - Method of Measurement, and substitute the following:**

**804.4 Method of Measurement.** No measure of topsoil will be made.

**Delete 804.5 - Basis of Payment, and substitute the following:**

**804.5 Basis of Payment.** All cost for supplying topsoil to project site shall be included in other items.

## **SECTION 805 - SEEDING**

### **Add Sec 805.2.3:**

Seed shall be applied at the rate of 200 pounds per acre of "Kentucky 31" tall fescue and 50 pounds per acre of annual rye.

### **Modify Sec. 805.3.2 by deleting the first sentence of second paragraph and adding the following:**

Seeding shall be done before the proposed seedbed becomes eroded, crusted over, dried out, or otherwise in a non-tillable condition and shall not be done when the ground is in a frozen condition or covered with snow. If the seed is to be placed on the surface, seeding shall not be done during windy conditions. When partial application has been made.

### **Add Sec. 805.3.3:**

**805.3.3** The Contractor at his option and at no additional expense to the Owner, provide sod as specified herein in lieu of seeding in any or all areas required to be seeded.

### **Add Sec. 805.3.4:**

**805.3.4 Maintenance.** An established grass cover shall be provided on all areas requiring seeding. Irrigation, mulching, mowing, and any other operation necessary to provide an acceptable grass cover shall be provided by the Contractor at no additional cost to the Owner.

### **Add Sec. 805.3.5:**

**805.3.5 Protection and Repair.** The seeded area shall be free of traffic. If at any time before final acceptance, areas which have become eroded or otherwise damaged or areas which have seeded areas damaged or destroyed, the affected portion shall be repaired to reestablish the specified condition prior to final acceptance of the work.

### **Add Sec. 805.3.6:**

**805.3.6 Submittals.** The Contractor shall furnish certifications from the supplier or manufacturer of seeds, sods, fertilizers, and all other materials furnished in accordance with the requirements of this section as well as Section 801 and 802. The certifications shall state that each material supplied meets the minimum requirements of specifically named state laws and regulations. The certifications shall have attached inspection or test reports of governing state agencies applicable to the lot or lots of material supplied.

## **SECTION 806 EROSION CONTROL BLANKETS AND NETTING**

Delete this entire section.

**SECTION 807 - TEMPORARY EROSION & SEDIMENT CONTROL**

**807.1 General.**

**807.1.1 Description.** This work shall consist of furnishing, installing, maintaining, and removing when directed, temporary control measures as shown on the plans or ordered by the Engineer. The control of water pollution will be accomplished through the use of berms, slope drains, ditch checks, sediment basins, seeding and mulching, bales, silt fences, and other erosion control devices or methods, in accordance with the these specifications.

The temporary pollution control provisions contained herein shall be coordinated with the permanent erosion control features specified elsewhere in the contract to assure economical, effective and continuous erosion control. These provisions shall also apply to work within easements designated on the plans or coordinated with the landowners.

**807.1.2 Purpose.** The purpose of these specifications is to set forth certain temporary water pollution control measures which shall be required of the Contractor.

The Contractor shall exercise best management practices throughout the life of the project to control water pollution. Construction of permanent drainage facilities as well as performance of other contract work which may contribute to the control of siltation shall be accomplished at the earliest practicable time. Pollutants such as chemicals, fuels, lubricants, bitumens, raw sewage, or other harmful material shall not be discharged from the project.

**807.1.3 Pre-Construction Conference.** Prior to the start of construction, the Contractor shall submit for acceptance his schedules for the implementation of temporary and permanent erosion control work, as are applicable for clearing and grubbing; grading; bridges and other structures at watercourses; construction; and paving. No work shall be started until the erosion control sequences and methods of operations have been approved by the Engineer.

**807.2 Material Requirements.**

**807.2.1** Materials required by this provision shall meet the following Missouri Standard Specifications for Highway Construction sections:

<u>Description</u>	<u>Section</u>
Fertilizer and Lime	801
Straw for Bales	802
Mulching, Rates and Materials	802
Seed	805
Geotextile Fabric	As Required Herein

### **807.3 General Construction Requirements.**

**807.3.1** The Engineer may limit the surface area of erodible earth material exposed by clearing and grubbing, the surface area of erodible earth material exposed by excavation, borrow, and fill operations, and may direct the Contractor to provide immediate permanent or temporary pollution control measures to prevent contamination of adjacent streams or other watercourses, lakes, ponds, or other areas of water impoundment. Such work may involve the construction of berms, dikes, sediment basins, slope drains, and use of temporary mulches, seeding or other control devices or methods as necessary to control erosion.

**807.3.2** The Contractor shall be required to incorporate all permanent erosion control features into the project at the earliest practicable time. Temporary pollution control measures shall be used to correct conditions that develop during construction which were not foreseen during the design stage; that are needed prior to installation of permanent pollution control features; or that are needed temporarily to control erosion that develops during normal construction practices, but are not associated with permanent control features on the project.

**807.3.3** Clearing and grubbing operations shall be so scheduled and performed that grading operations and permanent erosion control features will follow immediately thereafter. The surface area of erodible earth material exposed at one time by clearing and grubbing, by excavation, by fill, or by borrow shall not exceed 325,000 square feet without the written approval of the Engineer.

**807.3.4** The Engineer will limit the area of clearing and grubbing excavation, borrow and embankment operations in progress commensurate with the Contractor's capability and progress in keeping the finish grading, mulching, seeding, and other such permanent pollution control measures current. Should seasonal limitations make such coordination unrealistic, temporary erosion control measures shall be taken immediately.

**807.3.5** The Engineer may increase or decrease the amount of surface area of erodible earth material to be exposed at one time by clearing and grubbing, excavation, borrow and fill operations as determined by his analysis of project conditions.

**807.3.6** Unless otherwise provided or approved in writing by the Engineer, construction operations in rivers, streams, and impoundments shall be restricted to those areas which must be entered for the construction of temporary or permanent structures. Rivers, streams, and impoundments shall be promptly cleared of all falsework piling, debris or other obstructions placed therein or caused by the construction operations.

**807.3.7** Frequent fording of live streams with construction equipment will not be permitted. Temporary bridges or other structures shall be used wherever an appreciable number of stream crossings are necessary. Unless otherwise approved in writing by the Engineer, mechanized equipment shall not be operated in live streams except as may be

required to construct channel changes and temporary or permanent structures. If a Section 404 permit is applicable for this project, its requirements and/or conditions shall prevail.

**807.3.8** The location of all local material pits other than commercially operated sources, and all excess material areas shall be subject to the approval of the Engineer, and construction operations shall be conducted and pollution control measures implemented so that erosion will not result in water pollution.

**807.3.9** In the event of conflict between these requirements and pollution control laws, rules, or regulations of other Federal, State, or local agencies, the more restrictive laws, rules, or regulations shall apply.

#### **807.4 Temporary Berms.**

**807.4.1 Description.** A temporary ridge of compacted soil, with or without a shallow ditch, constructed at the top of fill slopes or transverse to center line on fills.

**807.4.2 Purpose.** The purpose of these ridges is to divert storm runoff from small areas away from steep slopes and direct this water to temporary outlets where the water can be discharged with minimum erosion.

**807.4.3 Conditions Where Applicable.** These ridges are used temporarily at the top of newly constructed slopes to prevent excessive erosion until permanent controls are installed and/or slopes are stabilized, as well as transverse to grade to divert runoff to stabilized slope drains. Two types of temporary berms will be utilized under conditions listed below:

##### **807.4.3.1 Type "A" Berm.**

- a. At the end of each day's operations on embankments.

##### **807.4.3.2 Type "B" Berm.**

- a. When embankment operations are shut down over the winter season or discontinued at the direction of or with the concurrence of the Engineer.

**807.4.3.3** Interceptor berms transverse to center line may be used when temporary berms are installed on all grades in excess of 1% and at all locations where water is to be carried down the fill slope by temporary or permanent slope drains.

#### **807.4.4 Construction Requirements.**

##### **807.4.4.1 Type "A" Berms.**

- a. Type "A" Berms will be constructed to the approximate dimensions as indicated on the attached typical drawing. These berms will be machine compacted with a minimum of one pass over the entire width of the berm with a dozer tread, grader wheel, etc.

#### **807.4.4.2 Type "B" Berms.**

- a. Type "B" Berms will be constructed to the approximate dimensions as indicated in the plans. These berms will be machine compacted with a minimum of three (3) passes over the entire width of the berm with a dozer tread, grader wheel, etc.

#### **807.4.4.3 Type "A" and Type "B" Berms.**

- a. Temporary berms must drain to a compacted outlet at a slope drain. The top width of these berms may be wider and the side slopes flatter on transverse berms to allow equipment to pass over these berms with a minimal disruption.

#### **807.4.5 Method of Measurement and Payment.**

**807.4.5.1** Type "A" Berms will be a part of the excavation operations and included in the unit bid prices for other grading items.

**807.4.5.2** Type "B" temporary berms will be measured and paid by the linear foot. The unit bid price for Type "B" Berms will include installation, maintenance, and removal. Any handwork at slope drain inlets will be a part of the unit bid price for slope drains. Material removed from Type "B" Berms may be incorporated in the embankment, if possible, or disposed of by the Contractor in accordance with the applicable requirements of these specifications.

#### **807.5 Temporary Slope Drains.**

**807.5.1 Description.** A temporary facility consisting of stone, concrete or asphalt gutters, half-round pipe, metal pipe, plastic pipe, or flexible rubber pipe, used to carry water down slopes to reduce erosion. The method selected shall meet the approval of the Engineer.

**807.5.2 Conditions Where Applicable.** Temporary slope drains are required to carry water flowing from cut sections down the fill slopes prior to the time permanent facilities are installed. Also, temporary slope drains are required on fill slopes at approximately 500 foot intervals or as directed by the Engineer.

#### **807.5.3 Construction Requirements.**

**807.5.3.1** All temporary slope drains will be adequately anchored to the slope to prevent disruption by the force of the water flowing in these drains. The inlet end will be

properly constructed to channel water into the temporary drain. The outlet ends of these temporary slope drains will have some means of dissipating the energy of this water to reduce erosion downstream. Unless otherwise specified by the Engineer, all temporary slope drains will be removed when no longer necessary and the site restored to match the surroundings.

**807.5.4 Method of Measurement and Payment.** Temporary slope drains will be measured per linear foot. The necessary inlet and outlet preparation and installation, as well as maintenance and removal of the entire facility shall be considered incidental construction and included in this unit bid price.

## **807.6 Ditch Checks.**

### **807.6.1 Construction Requirements.**

#### **807.6.1.1 Rock Ditch Check.**

- a. Rock ditch checks shall be constructed of two (2) to three (3) inch clean gravel or limestone. The gravel shall be placed according to the configuration shown in the plans. Hand or mechanical placement will be necessary to achieve complete coverage of the ditch or swale and to insure that the center of the check is lower than the edges.

#### **807.6.1.2 Straw Bale Ditch Check.**

- a. Straw bale ditch checks shall be constructed according to the plans and specifications for the ditch application of the Straw Bale Ditch Check.

#### **807.6.1.3 Silt Fence Ditch Check.**

- a. Silt fence ditch checks shall be constructed according to the plans and specifications for the ditch application of the Silt Fence Ditch Check.

### **807.6.2 Maintenance.**

#### **807.6.2.1 Rock Ditch Check.**

- a. Ditch checks shall be checked for sediment accumulation after each significant rainfall. Sediment shall be removed when it reaches one-half (2) of the original height or before. Any removal of accumulated sediment necessary as requested by the Engineer will be paid per cubic yard. Sediment removal will include removal and disposition in a location where it will not erode into construction areas or water courses.

- b. Regular inspections shall be made to insure that the center of the check is lower than the edges. Erosion caused by high flows around the edges of the check shall be corrected immediately.

#### **807.6.2.2 Straw Bale Ditch Check.**

- a. Sediment deposits shall be removed upon direction of the Engineer. They must be removed when deposits reach approximately one half (2) the height of the barrier. Any removal of accumulated sediment necessary as requested by the Engineer will be paid per cubic yard. Sediment removal will include removal and disposition in a location where it will not erode into construction areas or water courses.

#### **807.6.2.3 Silt Fence Ditch Check.**

- a. Sediment deposits shall be removed upon direction of the Engineer. They must be removed when deposits reach approximately one-half (2) the height of the barrier. Any removal of accumulated sediment necessary as requested by the Engineer will be paid per cubic yard. Sediment removal will include removal and disposition in a location where it will not erode into construction areas or water courses.

**807.6.3 Method of Measurement and Payment.** Ditch checks shall be paid for per each separate installation, complete and in place. This includes maintaining and repairing original structure. Replacement costs may be authorized by the Engineer should unusual conditions warrant.

### **807.7 Sediment Basin.**

**807.7.1 Description.** A sediment basin is an excavated or dammed storage area with rock riprap placed in inlet and outlet areas with defined side slopes.

**807.7.2 Purpose.** Sediment basins are constructed to trap and store sediment from erodible areas in order to protect properties and stream channels below the installation from excessive siltation. These structures trap and store sediment that unavoidably occurs in spite of temporary erosion control measures in use.

#### **807.7.3 Construction Requirements.**

**807.7.3.1** The area where a sediment basin is to be constructed shall be cleared of vegetation to enable removal of sediment.

**807.7.3.2** The inlets of these sediment basins shall be constructed with a wide cross-section and a minimum grade to prevent turbulence and allow deposition of the soil particles. When the depth of sediment reaches one third (1/3) of the depth of structure in any part of the pool, all accumulation shall be removed.

**807.7.3.3** Sediment basins shall normally remain in service until all disturbed areas draining into the structure have been satisfactorily stabilized. When use of temporary sediment basins is to be discontinued, all excavations are to be backfilled and properly compacted, fill material, if any, removed and the existing ground restored to its natural or intended condition.

**807.7.3.4** Removed accumulated sediment and excavated material removed during construction of the sediment basin shall be disposed of in locations that the sediment will not again erode into the construction areas or into natural waterways.

#### **807.7.4 Method of Measurement and Basis of Payment.**

**807.7.4.1** Sediment basins will be measured per cubic yard excavated which unit price shall include excavation, disposition of excavated material, and removal and restoration when no longer required, along with the furnishing of rock riprap for inlet and outlet control.

**807.7.4.2** Additional clearing and grubbing necessary for construction of the sediment basins will be included in the unit price for the sediment basin. All seeding and mulching required after the sediment basin is built and also after removal and site restoration will be measured and paid at the unit bid prices for temporary or permanent seed, as the case may be.

**807.7.4.3** Sediment removal will be paid at a fixed unit price of \$20.00 per cubic yard. Sediment removal will include removal and disposition in a location where it will not erode into construction areas or watercourses.

#### **807.8 Temporary Seeding and Mulching.**

**807.8.1 Description:** This work shall consist of fertilizing, furnishing, and sowing of seed, Type 1 mulching or other acceptable cover if authorized by the Engineer.

**807.8.2 Purpose.** The purpose of temporary seeding and mulching is to produce a quick ground cover to reduce erosion in disturbed areas that are expected to be redisturbed at a later date. Finished grading of areas will not be required. Hydroseeding allowing mixing of fertilizer and seed will be allowed.

#### **807.8.3 Construction Requirements.**

**807.8.3.1** Seeding and/or mulching will be a continuous operation on all cut and fill slopes, excess material sites, and borrow pits during the construction process. All disturbed areas shall be seeded and mulched when and where necessary to eliminate erosion.

**807.8.3.2** Permanent seeding and mulching following the temporary seeding will be performed according to Standard Specifications Section 805 and will be permitted during the favorable seeding seasons only.

**807.8.3.3 Temporary Seeding Mixtures and Planting Season.**

- a. December 1 to March 1 - Per Acre  
50 lbs Oat Grain
- b. March 1 to December 1 - Per Acre  
100 lbs (cereal rye or wheat)

**807.8.3.4 Temporary Mulch, Temporary Fertilizer, and Lime for Seeding.**

- a. Temporary mulch placed over temporary seed mixtures shall be applied in accordance with the provisions of Section 802.2.1 of the Standard Specifications.
- b. Fertilizer shall be applied at the rate of 40 lb/acre of nitrogen (N).

**807.8.4 Method of Measurement and Payment.** All temporary seed mixtures and the accompanying mulch will be paid per acre, measured to the nearest 1/10 acre.

**807.9 Straw Bales.**

**807.9.1 Description.** Bales of straw used as a means of controlling pollution and erosion. Other foliage may be substituted for straw in accordance with Section 802.2.1 of the Standard Specifications.

**807.9.2 Purpose.** To obstruct the flow of water to allow deposit of sediment and/or divert water.

**807.9.3 Conditions Where Applicable.**

**807.9.3.1** Use at the bottom of embankment slopes to divert runoff from sheet flow and also catch some of the sediment picked up in the sheet flow.

**807.9.3.2** As ditch checks in small ditches and drainage areas.

**807.9.3.3** On the lower side of the cleared areas to catch sediment from sheet flow.

**807.9.4 Construction Requirements.**

**807.9.4.1** Bales of straw will be utilized to control erosion, trap sediment, and divert runoff as directed and approved by the Engineer. When used to trap sediment or divert runoff, the bales must be adequately braced from behind.

**807.9.5 Method of Measurement and Payment.** Bales of straw for temporary erosion control will be paid for at the contract unit price bid per linear foot which unit price shall cover furnishing, installation, and removal and disposal when no longer required.

#### **807.10 Silt Fence.**

**807.10.1 Description.** This work consists of furnishing, installing, maintaining, and removing a geotextile barrier-fence designed to remove suspended particles from water passing through the fence. The quantities of temporary silt fence shown on the plans may be increased or decreased at the direction of the Engineer based on weather, construction procedures, and actual site conditions that occur during construction of the project. Such variations in quantity will not be considered as alterations in the details of construction or a change in the character of the work.

#### **807.10.2 Materials.**

**807.10.2.1** This specification provides criteria for wire-supported geotextile silt fence as well as a self-supporting geotextile silt fence.

**807.10.2.2** Fibers used in the manufacture of geotextiles shall consist of longchain synthetic polymers, composed of at least 85 percent (85%) by weight polyolefins, polyesters, or polyamides. They shall be formed into a network such that the filaments or yarns retain dimensional stability relative to each other, including selvages. The geotextile shall be free of any treatment or coating which might adversely alter its physical properties after installation. Unless otherwise specified, geotextile shall be furnished in thirty-six (36) inch width rolls.

**807.10.2.3** Geotextile rolls shall be furnished with suitable wrapping for protection against moisture and extended ultraviolet exposure prior to placement. Each roll shall be labeled or tagged to provide product identification sufficient for inventory and quality control purposes. Rolls shall be stored in a manner which protects them from the elements.

**807.10.2.4 Posts.** Either wood, steel, or synthetic posts may be used. Posts shall have a minimum length of twenty-four (24) inches plus embedment depth and be of sufficient strength to resist damage during installation and to support applied loads.

**807.10.2.5 Support Fence.** Wire or other support fence shall be at least twenty-four (24) inches high and strong enough to support applied loads.

**807.10.2.6 Prefabricated Fence.** Prefabricated fence systems may be used provided they meet all of the above material requirements.

**807.10.3 Certification and Sampling.** The Contractor shall furnish a manufacturer's certification, in triplicate, stating that the material supplied conforms to the requirements of these specifications. The certification shall include or have attached, typical results of tests for the specified properties, representative of the materials supplied. The Engineer

reserves the right to sample and test any material offered for use. Acceptance will be based on the certification and the results of any tests the Engineer may perform.

#### **807.10.4 Construction Requirements.**

**807.10.4.1** The Contractor shall install a temporary silt fence as shown on the plans, and at other locations as directed by the Engineer. Fence construction shall be adequate to handle the stress from hydraulic and sediment loading. Geotextile at the bottom of the fence shall be buried as indicated on the standard drawing. The trench shall be backfilled and the soil compacted over the geotextile. The geotextiles shall be spliced together as indicated on the standard drawings.

**807.10.4.2** Post spacing shall not exceed eight (8) feet for wire support fence installations or five (5) feet for self-supported installations. Posts shall be driven a minimum of twenty-four (24) inches into the ground. Where rock is encountered posts shall be installed in a manner approved by the Engineer. Closer spacing, greater embedment depth and/or wider posts shall be used as necessary in low areas and soft or swampy ground to ensure adequate resistance to applied loads.

**807.10.4.3** When support fence is used, the mesh shall be fastened securely to the up-slope side of the post. The mesh shall extend into the trench a minimum of two (2) inches and extend a maximum of thirty-six (36) inches above the original ground surface.

**807.10.4.4** When self-supported fence is used, the geotextile shall be securely fastened to fence posts.

**807.10.4.5** It is the Contractor's responsibility to maintain the integrity of silt fences as long as they are necessary to contain sediment runoff. The Contractor shall inspect all temporary silt fences immediately after each rainfall and at least daily during prolonged rainfall. Any deficiencies shall be immediately corrected by the Contractor. In addition, the Contractor shall make a daily review of location of silt fences in areas where construction activities have changed the natural contour and drainage runoff to ensure that the silt fences are properly located for effectiveness. Where deficiencies exist, additional silt fences shall be installed as approved or directed by the Engineer.

**807.10.4.6** The Contractor shall remove and dispose of sediment deposits when the deposit approaches one half (1/2) height of the fence or sooner when directed by the Engineer. If required by heavy sediment loading, a second silt fence shall be installed as directed by the Engineer.

**807.10.4.7** The silt fence shall remain in place until the Engineer directs that it be removed. Upon removal, the Contractor shall remove and dispose of any excess silt accumulations, grade and dress the area to the satisfaction of the Engineer, and establish vegetation on all bare areas in accordance with the contract requirements.

**807.10.5 Method of Measurement.** The quantity of temporary silt fence to be paid for will be the actual number of linear feet of silt fence, measured in place from end post to

end post of each separate installation which has been completed and accepted. Measurement of sediment removal will be made to the nearest cubic removal.

**807.10.6 Basis of Payment.** Temporary silt fence, measured as defined above, will be paid for at the contract unit price bid per linear foot. Such payment shall be full compensation for furnishing all materials, erecting, maintaining, and removing the fence. Removing and disposing of accumulated sediment will be paid for at the contract unit price for sediment removal.

**Table 1**

**PHYSICAL REQUIREMENTS<sup>1</sup> FOR TEMPORARY SILT FENCE GEOTEXTILES**

<u>Property</u>	<u>Test Method</u>	<u>Wire Fence Supported Requirements</u>	<u>Self-Supported Requirements</u>
Tensile Strength Lbs.	ASTM D4632	90 Minimum <sup>2</sup>	90 Minimum <sup>2</sup>
Elongation at 50% Minimum Tensile Strength. (45 lbs)	ASTM D4632	N/A	50 Maximum
Filtering Efficiency	VTM-51 <sup>3</sup>	75	75
Flow Rate, gal/ft <sup>2</sup> /min	VTM-51 <sup>3</sup>	0.3	0.3
Ultraviolet Degradation at 500 hours	ASTM D4355	Minimum 70% Strength Retained	Minimum 70% Strength Retained

1. All numerical values represent minimum average roll value.

2. When tested in any principal direction.

3. Virginia DOT test method.

**807.11 Temporary Pipe.**

**807.11.1 Description.** Conduit, of a material acceptable to the Engineer, utilized temporarily to carry water under a haul road, silt fences, etc.

**807.11.2 Purpose.** To prevent the Contractor's equipment from coming in direct contact with the water when crossing an active stream or intermittent streams created during heavy rainfalls.

**807.11.3 Conditions Where Applicable.** In streams that must be crossed by the Contractor's equipment and hollows which become a stream during heavy rainfall that are traversed by the Contractor's equipment.

#### **807.11.4 Construction Requirements.**

**807.11.4.1** All temporary pipe shall be installed in the same manner as permanent pipe is installed on the project to assure that the water does not cause erosion around the pipe. Material to backfill the pipe should be placed in six (6) inch lifts and mechanically compacted although a compaction test will not be required.

**807.11.5 Method of Payment.** Temporary pipe will be paid per linear foot complete and in place which price will include furnishing, installation, maintenance, and removal when no longer required.

#### **807.12 Ditch Stabilization Structures.**

##### **807.12.1 Material.**

- a. The material for ditch stabilization structures shall consist of a riprap consisting of durable stone or shot rock with a predominant size of 6 inches, a maximum size of 10 inches and a gradation such that no more than 15 percent will be less than 3 inches. Acceptance by the engineer may be made by visual inspection.

##### **807.12.1 Construction Requirements.**

- a. The riprap shall be placed in accordance with the configuration shown in the plans. Hand or mechanical placement will be necessary to achieve complete coverage of the ditch or swale and to insure that the top of the rock is placed at the same elevation of the ditch or swale.

##### **807.12.2 Maintenance.**

- a. Ditch stabilization structures shall be checked for erosion of the rock from the structure. If erosion occurs, the ditch shall be immediately regraded and additional rock placed in the structure. Areas disturbed by the repairs shall be reseeded.
- b. The Contractor shall be responsible for maintenance of these structures until final acceptance.

**807.12.3 Method of Measurement and Payment.** Ditch stabilization structures shall be paid for per each separate installation, complete and in place. This includes maintaining and repairing original structure. Replacement costs may be authorized by the Engineer should unusual conditions warrant.

**807.13 Basis of Payment.** The quantities, determined as provided above, will be paid at the contract unit prices bid for the items listed below.

##### **807.13.2 Pay Items.**

Item 807.10	"Temporary Berms (Type B)", per linear foot
Item 807.11	"Slope Drains", per linear foot
Item 807.12	"Rock Ditch Checks", per each
Item 807.13	"Straw Bale Ditch Check", per each
Item 807.14	"Silt Fence Ditch Check", per each
Item 807.15	"Sediment Basins", per cubic yard
Item 807.16*	"Sediment Removal", per cubic yard
Item 807.17	"Temporary Seeding and Mulching", per acre
Item 807.18	"Straw Bales" (Fence), per linear foot
Item 807.19	"Silt Fence", per linear foot
Item 807.20	"Temporary Pipe", per linear foot
Item 807.22	"Ditch Stabilization Structures", per each

\* - Fixed unit price of \$20.00 per cubic yard.

### **SECTION 903 - HIGHWAY SIGNING**

Delete entire section

### **SECTION 904 – GEOTEXTILE**

**904.1 Geotextile Fabric (Under Shot Rock).** This work shall consist of installing the geotextile fabric beneath the shot rock.

**904.1.1 Materials.** The geotextile fabric used to underlay the shot rock shall consist of woven or non-woven polypropylene or polyester. The Contractor shall submit to the Engineer a copy of manufacturer's certification showing the material meets the minimum requirements and a copy of the installation instructions. The fabric shall meet the following minimum values:

**904.1.1.1** Grab Tensile Strength - 180 lbs.

**904.1.1.2** Puncture Strength - 80 psi

**904.1.1.3** Trapezoidal Strength - 50 lbs.

**904.1.1.4** Burst Strength - 290 psi

**904.1.2 Construction Requirements.**

**904.1.2.1** The geotextile fabric shall be installed in accordance with the manufacturer's recommendations.

**904.1.2.2** The fabric shall not be exposed to sunlight for more than two weeks.

**904.1.2.3** The Contractor shall repair any fabric damaged during the installation or shot rock placement in accordance with the manufacturer's recommendations.

**904.1.2.4 Method of Measurement.** Measurement of the geotextile fabric shall be to nearest square yard.

**904.1.3 Basis of Payment.** The accepted quantities of geotextile fabric will be paid for at the unit price in the contract.

## **SECTION 1005 - AGGREGATE FOR CONCRETE**

**Delete Sec. 1005.3.6 - Sampling, and substitute the following:**

**1005.3.6 Sampling.** Actual mix design shall be prepared and submitted by the Contractor to the Engineer for approval. Submittal shall include source and properties of all aggregate, source of cement, proportions used, slump, air content and results of breaks of four (4) test cylinders. Cylinders shall be broken as follows: two (2) @ seven (7) days and two (2) @ twenty-eight (28) days. Minimum compressive strength to be 2800 psi @ seven (7) days and 4000 psi @ twenty-eight (28) days. The maximum time a mix design will be used will be two (2) construction seasons.

STATE OF MISSOURI  
DEPARTMENT OF NATURAL RESOURCES  
MISSOURI CLEAN WATER COMMISSION



MISSOURI STATE OPERATING PERMIT

General Operating Permit

In compliance with the Missouri Clean Water Law, (Chapter 644 R.S. Mo as amended, hereinafter, the Law), and the Federal Water Pollution Control Act (Public Law 92-500, 92nd Congress) as amended,

Permit No MOR100034  
Owner: Cole County  
Address: 301 E High Street  
Room 200  
Jefferson City, MO 65109  
  
Continuing Authority: Cole County Road and Bridge Department  
5055 Monticello Rd.  
Jefferson City, MO 65109  
  
Facility Name: Cole County Public Works  
Facility Address: 5055 Monticello Rd  
JEFFERSON CITY, MO 65109  
  
Legal Description: Sec. 04, T43N, R12W, Cole County  
UTM Coordinates: 565135.257/4262453.882  
Receiving Stream: Tributary to Moreau R. (U)  
First Classified Stream - ID#: 8-20-13 MUDD V1.0 (C) 3960.00  
USGS# and Sub Watershed#: 10300102 - 1206

is authorized to discharge from the facility described herein, in accordance with the effluent limitations and monitoring requirements as set forth herein.

**FACILITY DESCRIPTION** All Outfalls SIC #1629  
All Outfalls - Construction or land disturbance activity (e.g., clearing, grubbing, excavating, grading, filling and other activity that results in the destruction of the root zone and/or land disturbance activity that is reasonably certain to cause pollution of waters of the state)

This permit authorizes only wastewater, including storm water, discharges under the Missouri Clean Water Law and the National Pollutant Discharge Elimination System, it does not apply to other regulated areas. This permit may be appealed in accordance with RSMo Section 644.051.6 and 621.250, 10 CSR 20-6.020, and 10 CSR 20-1.020.

September 01, 2017  
Issue Date

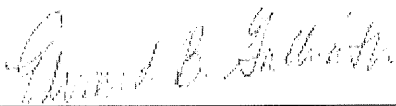
  
\_\_\_\_\_  
Edward B. Galbraith, Director  
Division of Environmental Quality

June 22, 2022  
Expiration Date

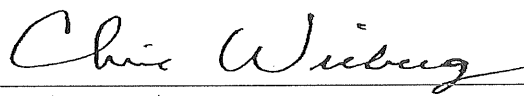
  
\_\_\_\_\_  
Chris Wieberg, Director  
Water Protection Program

## APPLICABILITY

1. This general permit authorizes the discharge of stormwater and certain non-stormwater discharges from land disturbance sites that disturb one or more acres or disturb less than one acre when part of a larger common plan of development or sale that will disturb a cumulative total of one or more acres over the life of the project. This general permit also authorizes the discharge of stormwater and certain non-stormwater discharges from smaller projects where the Missouri Department of Natural Resources (department) has exercised its discretion to require a permit [10 CSR 20-6.200(1)(B)].
2. This general permit is issued to a city, county, state or federal agency or other governmental jurisdiction for land disturbance projects performed by or under contract to the permittee.
3. A general stormwater control plan or stormwater pollution prevention plan (SWPPP) must be developed prior to issuance of this permit. These plans must include a narrative of the types and appropriate uses of Best Management Practices (BMPs) for erosion and sediment control and stormwater management. All water pollution controls on land disturbance sites shall conform to the storm water control program and/or SWPPP of the city, county or other governmental jurisdiction in which the land disturbance activity is occurring. The requirements of the stormwater control program and/or SWPPP must be at least as stringent as those described in this permit and 10 CSR 20-6.200.
4. A Missouri State Operating Permit must be issued before any site vegetation is removed or the site disturbed. Any site owner/operator subject to these requirements for stormwater discharges and who disturbs land prior to permit issuance from the department is in violation of both State regulations per 10 CSR 20-6.200(1)(A) and Federal regulations per 40 CFR 122.26. The legal owner of the property, right-of-way or the holder of an easement on the property, and operator on which the site is located are responsible for compliance with this permit.
5. This permit authorizes discharges from construction support activities (e.g., concrete or asphalt batch plants, equipment staging yards, material storage areas, excavated material disposal areas, borrow areas) provided that appropriate stormwater controls are designed, installed, maintained and provided:
  - a. The support activity is directly related to the construction site required to have permit coverage for stormwater discharges;
  - b. The support activity is not a commercial operation; and
  - c. The support activity does not continue to operate beyond the completion of the construction activity at the project it supports.The permittee is responsible for compliance with this permit for any construction support activities.
6. This permit authorizes non-stormwater discharges from the following activities provided that these discharges are addressed in the permittee's specific SWPPP required by this general permit:
  - a. Dewatering activities if there are no contaminants other than sediment present in the discharge, and the discharge is treated as specified in Requirements, Section 10.o. of this permit;
  - b. Flushing water hydrants and potable water lines;
  - c. Water only (i.e., without detergents or additives) rinsing of streets and buildings; and
  - d. Site watering to establish vegetation.
7. This general permit does not authorize the:
  - a. placement of fill materials in waters or floodplains
  - b. obstruction of stream flow,
  - c. redirection of stormwater across private property not owned or operated by the permittee, or

d. Changing the channel of a defined drainage course.

These actions may be regulated by other federal, state, or local entities, such as the U.S. Army Corps of Engineers or Federal Emergency Management Agency. This general permit addresses only the quality of the stormwater runoff and the minimization of off-site migration of sediments and other water contaminants.

8. This permit does not authorize land disturbance activity in jurisdictional waters of the United States, unless the permittee has obtained the required Clean Water Act Section 404 Department of the Army permit from the U.S. Army Corps of Engineers and its associated Section 401 Water Quality Certification from the department. Land disturbance activities may not begin in the affected waters of the United States until the required §404 permit and §401 water quality certification have been obtained.
9. This general permit prohibits any discharge of wastewater generated from air pollution control equipment or the containment of scrubber water in lined ponds to waters of the state.
10. This general permit prohibits any discharge of sewage or pollutants to waters of the state including but not limited to:
  - a. Any hazardous material, oil, lubricant, solid waste or other non-naturally occurring substance from the site, including fuels, oils, or other pollutants used in vehicle and equipment operation and maintenance;
  - b. Soaps or solvents used in vehicle and equipment washing;
  - c. Hazardous substances or petroleum products from an on-site spill or handling and disposal practices;
  - d. Wash and/or rinse waters from concrete mixing equipment including ready mix concrete trucks, unless managed by an appropriate control. Any such pollutants must be adequately treated and addressed in the SWPPP, and cannot be discharged to waters of the state;
  - e. Wastewater from washout and cleanout of stucco, paint, form release oils, curing compounds and other construction materials;
  - f. Domestic wastewaters, including gray waters; or
  - g. Industrial stormwater runoff.
11. The department reserves the right to revoke or deny coverage under this general permit to applicants for stormwater discharges from land disturbance activities at sites that have contaminated soils that will be disturbed by the land disturbance activity or where such materials are brought to the site to use as fill or borrow. A site-specific permit may be required to cover such activities.
12. If at any time the department determines that the quality of waters of the state may be better protected by requiring the owner/operator of the permitted site to apply for a site-specific or different general permit, the department may do so [10 CSR 20-6.010(13)(C)]. Examples of when this may occur:
  - a. The permittee is not in compliance with the conditions of this general permit;
  - b. The discharge no longer qualifies for this general permit due to changed site conditions and/or regulations; or
  - c. Information becomes available that indicates water quality standards have been or may be violated.The permittee will be notified in writing of the requirement to apply for a site-specific permit or a different general permit. When issued to the authorized permittee, the applicability of this general permit to the permittee is automatically terminated upon the effective date of the site-specific or different general permit.
13. Any owner/operator authorized by a general permit may request to be excluded from the coverage of the general permit and apply for a site-specific permit [10 CSR 20-6.010(13)(D)].

14. This operating permit does not affect, remove, or replace any requirement of the National Environmental Policy Act; the Endangered Species Act; the National Historic Preservation Act; the Comprehensive Environmental Response, Compensation and Liability Act; or the Resource Conservation and Recovery Act. Determination of applicability for the above mentioned acts is the responsibility of the permittee.
15. This permit does not supersede any requirement for obtaining project approval under an established local authority.
16. This permit is not transferable to other owners or operators.

#### EXEMPTIONS FROM PERMIT REQUIREMENTS

1. Facilities that discharge all stormwater runoff directly to a combined sewer system are exempt from stormwater permit requirements.
2. Land disturbance activity as described in 10 CSR 20-6.010(1)(B) and 10 CSR 20-6.200(1)(B).
3. Oil and gas related activities as listed in 40 CFR 122.26(a)(2)(ii).

#### REQUIREMENTS

1. Electronic Discharge Monitoring Report (eDMR) Submission System.  
Per 40 CFR Part 127 National Pollutant Discharge Elimination System (NPDES) Electronic Reporting Rule, reporting shall be submitted by the permittee via an electronic system to ensure timely, complete, accurate, and nationally-consistent set of data about the NPDES program. All general permit covered facilities under this master general permit shall comply with the department's requirements for electronic reporting.
  - a. Reporting Requirements.
    - (1) Application to participate in the department's eDMR system is required as part of the application for general permit coverage in order to constitute a complete permit application and may be accessed at [dnr.mo.gov/env/wpp/edmr.htm](http://dnr.mo.gov/env/wpp/edmr.htm).
    - (2) The permittee must electronically submit quarterly reports via the eDMR system.
  - b. Other actions. The following shall be submitted electronically after such a system has been made available by the department:
    - (1) General Permit Applications/Notices of Intent to discharge (NOIs);
    - (2) Notices of Termination (NOTs);
    - (3) No Exposure Certifications (NOEs); and
    - (4) Low Erosivity Waivers and Other Waivers from Stormwater Controls (LEWs).
  - c. Electronic Submissions. To access the eDMR system, use the following web link: <https://edmr.dnr.mo.gov/edmr/E2/Shared/Pages/Main/Login.aspx>.
  - d. Waivers from Electronic Reporting.
    - (1) The permittee must electronically submit reports unless a waiver is granted by the department in compliance with 40 CFR Part 127.
    - (2) The permittee may obtain a temporary or permanent electronic reporting waiver by first submitting an eDMR Waiver Request Form (Form 780-2692: <http://dnr.mo.gov/forms/780-2692-f.pdf>), by contacting the appropriate permitting office or emailing [edmr@dnr.mo.gov](mailto:edmr@dnr.mo.gov)). The department will either approve or deny this electronic reporting waiver request within 120 calendar days of receipt.
    - (3) Only permittees with an approved waiver request may submit reports on paper to the Department for the period that the approved electronic reporting waiver is effective.
2. Quarterly Reports: Permittees shall prepare a quarterly report with a list of active land disturbance sites including any off-site borrow or depositional areas associated with the construction project

and submit the following information electronically as an attachment to the eDMR system until such a time when the current or a new system is available to allow direct input of the data:

- a. The name of the project;
- b. The location of the project (including the county);
- c. The name of the primary receiving water(s) for each project;
- d. A description of the project;
- e. The number of acres disturbed;
- f. The percent of completion of the project;
- g. The projected date of completion.

The quarterly report(s) shall be maintained by the permittee and readily available for review by the department at the address provided on the application as well as submitted to the department quarterly via the department's eDMR system. When a permittee terminates permit coverage, the permittee shall submit with the request for termination, the final quarterly report for the current calendar quarter. The permittee shall submit quarterly reports according to Table A.

<b>Table A Schedule for Quarterly Reporting</b>	
Activity for the months of:	Report is due:
January, February, March (1st Quarter)	April 28
April, May, June (2nd Quarter)	July 28
July, August, September (3rd Quarter)	October 28
October, November, December (4th Quarter)	January 28

3. This permit is to ensure the design, installation and maintenance of effective erosion and sediment controls minimize the discharge of pollutants by:
  - a. Controlling stormwater volume and velocity within the site to minimize soil erosion;
  - b. Controlling stormwater discharges, including both peak flow rates and total stormwater volume, to minimize erosion at outlets and to minimize downstream channel and stream bank erosion and scour in the immediate vicinity of discharge points;
  - c. Minimizing the amount of soil exposed during construction activity;
  - d. Minimizing the disturbance of steep slopes;
  - e. Addressing factors such as the amount, frequency, intensity and duration of precipitation, the nature of resulting stormwater runoff, and soil characteristics, including the range of soil particle size expected to be present on the site to minimize sediment discharges from the site;
  - f. Providing and maintaining natural buffers around surface waters as detailed in 10.f,
  - g. Directing stormwater to vegetated areas to increase sediment removal and maximize stormwater infiltration and filtering, unless infeasible; and
  - h. Minimizing soil compaction and, unless infeasible, preserve topsoil. Minimizing soil compaction or preserving topsoil is not required where the intended function of a specific area of the site dictates that it be compacted or the topsoil be disturbed or removed.
4. Installation of Best Management Practices (BMPs) necessary to prevent soil erosion at the project boundary must be complete prior to the start of all phases of construction.
5. Install sediment controls along any perimeter areas of the site..
  - a. Remove any sediment per the manufacturer's instructions or before it has accumulated to one-half of the above-ground height of any perimeter control.
  - b. For sites where perimeter controls are infeasible, other practices shall be implemented to minimize discharges to perimeter areas of the site.
6. BMPs shall be maintained and remain in effective operating condition during the entire duration of the project, with repairs made within the timeframe specified in the Requirements Section 9 of this permit, until final stabilization has been achieved.
7. Minimize sediment track-out from the site.
  - a. Restrict vehicle traffic to properly designed exit points such as an aggregate stone with an underlying geotextile or non-woven filter fabric.

- b. Use appropriate stabilization techniques at all points that exit onto paved roads.
  - c. Remove any sediment that has been tracked out within the same business day or by the end of the next business day if track-out occurs on a non-business day.
8. SWPPP Development and Implementation: The primary requirement of this permit is the development and implementation of a SWPPP which incorporates site-specific practices to best minimize the soil exposure, soil erosion, and the discharge of pollutants. The permittee shall fully implement the provisions of the SWPPP required under this part as a condition of this general permit throughout the term of the land disturbance project. **The SWPPP must be developed prior to issuance of the permit and must be updated with details specific to the land disturbance site prior to conducting any land disturbance activities at the site.** Either an electronic copy or a paper copy of the SWPPP must be accessible to anyone on-site at all times when land disturbance operations are in progress, or other operational activities that may affect the maintenance or integrity of the BMP structures and made available as specified under the Records Section of this permit.
9. The SWPPP must:
- a. List and describe all points of discharge to receiving water(s);
  - b. Incorporate required practices identified below;
  - c. Incorporate erosion control practices specific to site conditions;
  - d. Provide for maintenance and adherence to the plan;
  - e. Discuss whether or not additional authorizations, such as a Section 404 permit and associated Section 401 Water Quality Certification are required for the project; and
  - f. Name the person responsible for inspection, operation and maintenance of BMPs.

The purpose of the SWPPP is to ensure the design, implementation, management and maintenance of BMPs in order to prevent sediment and other pollutants in stormwater discharges associated with the land disturbance activities; compliance with the Missouri Water Quality Standards; and compliance with the terms and conditions of this general permit.

The following manuals are acceptable resources for the selection of appropriate BMPs. *Developing Your Stormwater Pollution Prevention Plan: A Guide for Construction Sites*, (Document number EPA 833-R-06-004) published by the United States Environmental Protection Agency (USEPA) in May 2007. This manual as well as other information, including examples of construction SWPPPs, is available at the USEPA internet site at <https://www.epa.gov/npdes/developing-stormwater-pollution-prevention-plan-swppp>; and the latest version of *Protecting Water Quality: A field guide to erosion, sediment and stormwater best management practices for development sites in Missouri*, published by the department is available on the department's internet site at <http://www.dnr.mo.gov/env/wpp/wpep-guide.htm>.

The permittee is not limited to the use of these guidance manuals. Other guidance publications may be used to select appropriate BMPs. However, all BMPs should be described and justified in the SWPPP.

10. SWPPP Requirements: The following information and practices shall be provided for in the SWPPP:
- a. Nature of the Construction Activity: The SWPPP briefly must describe the nature of the construction activity, including:
    - (1) The function of the project (e.g., low density residential, shopping mall, highway, etc.);
    - (2) The intended sequence and timing of activities that disturb the soils at the site;
    - (3) Estimates of the total area expected to be disturbed by excavation, grading, or other construction activities including off-site borrow and fill areas; and
    - (4) A general map (e.g., United States Geological Survey quadrangle map, a portion of a city or county map, or other map) with enough detail to identify the location of the construction site and waters of the state within one mile of the site.

- b. Site Map: The SWPPP must contain a legible site map showing the site boundaries and points of discharge to receiving water(s) and identifying:
- (1) Direction(s) of stormwater flow and approximate slopes for all phases of construction activities;
  - (2) Areas of soil disturbance and areas that will not be disturbed (or a statement that all areas of the site will be disturbed unless otherwise noted);
  - (3) Location of permanent and temporary structural and non-structural BMPs identified in the SWPPP;
  - (4) Locations where stabilization practices are expected to occur;
  - (5) Locations of off-site material, waste, borrow or equipment storage areas;
  - (6) Locations of all waters of the state (including wetlands);
  - (7) Locations where stormwater discharges to a surface water; and
  - (8) Areas where final stabilization has been accomplished and no further construction-phase permit requirements apply.
- c. Site Description: In order to identify the site, the SWPPP shall include facility and points of discharge to receiving water(s) information. The SWPPP shall have sufficient information to be of practical use to contractors and site construction workers to guide the installation and maintenance of BMPs.
- d. Selection of Temporary and Permanent BMPs: The permittee shall select, install, use, operate and maintain appropriate BMPs for the permitted site and list them in the SWPPP.
- e. Preservation of trees and vegetation: The SWPPP shall require existing vegetation and trees to be preserved where practical.
- f. Surface Water Buffers: For surface waters of the state, defined as “all waters within the jurisdiction of this state, including all rivers, streams, lakes and other bodies of surface and subsurface water lying within or forming a part of the boundaries of the state which are not entirely confined and located completely upon lands owned, leased or otherwise controlled by a single person or by two or more persons jointly or as tenants in common, located on or adjacent to the site,” the permittee must comply with (1)-(3), except as noted in (4):
- (1) Provide and maintain a 50-foot undisturbed natural buffer;
  - (2) Provide and maintain a 50-foot undisturbed natural buffer that is less than 50 feet and is supplemented by erosion and sediment controls that achieve the sediment load reduction equivalent to a 50-foot undisturbed natural buffer; or
  - (3) If infeasible to provide and maintain an undisturbed natural buffer of any size, implement erosion and sediment controls to achieve the sediment load reduction equivalent to a 50-foot undisturbed natural buffer.
  - (4) The permittee is not required to comply with (1), (2) or (3) above if one of the following exceptions apply and documentation is provided in the SWPPP:
    - (a) As authorized per Clean Water Act Section 404 Department of the Army permit and its associated Section 401 Water Quality Certification from the department.
      1. The angle of any crossing shall be as perpendicular as feasible to the water course or natural stream buffer to minimize adverse impacts.
    - (b) If there is no discharge of stormwater to waters of the state through the area between the disturbed portions of the site and waters of the state located within 50 feet of your site. This includes situations where you have implemented permanent control measures that will prevent such discharges, such as a berm or other barrier.
    - (c) Where no natural buffer exists due to preexisting development disturbances that occurred prior to the initiation of planning for the current development of the site.
      1. Where some natural buffer exists but portions of the area within 50 feet of the waters of the state are occupied by preexisting development disturbances, you are required to comply with (1), (2), or (3) above.
    - (d) For linear projects where site constraints make it infeasible to implement a buffer or equivalent provided you limit disturbances within 50 feet of any waters of the state and/or you provide supplemental erosion and sediment controls to treat stormwater

discharges from earth disturbances within 50 feet of the water of state.

- (e) For small residential lot construction as defined as 'a lot being developed for residential purposes that will disturb less than 1 acre of land, but is part a larger common plan of development or sale,' one has the option of complying with (1), (2) or (3) above or one of the following alternatives:
  - 1. Tiered-technology approach where:
    - a. A 50-foot or larger buffer is retained, no additional requirements are needed,
    - b. The buffer is greater than 30 feet but less than 50 feet wide, implement double perimeter controls spaced a minimum of at least 5 feet apart between land disturbance and water of the state, or
    - c. A less than or equal to 30-foot buffer is maintained, implement double perimeter controls between land disturbance and water of the state and stabilization activities completed with 7 calendar days of temporary or permanent cessation of land disturbance; or
  - 2. Sediment discharge risk based on the site's slope, location and soil type when combined with buffer width.
  
- g. Measuring Buffer Width: Where the permittee is retaining a buffer of any size, the buffer should be measured perpendicularly from any of the following points, whichever is further landward from the water:
  - (1) The ordinary high water mark of the water body, defined as the line on the shore established by fluctuations of water and indicated by physical characteristics such as a clear, natural line impressed on the bank, shelving, changes in the character of soil, destruction of terrestrial vegetation, and/or the presence of litter and debris; or
  - (2) The edge of the stream or river bank, bluff, or cliff, whichever is applicable.
  
- h. Description of BMPs: The SWPPP shall include a description of both structural and non-structural BMPs used one or more times at the site, providing the following general information for each:
  - (1) Physical description of the BMP;
  - (2) Site conditions that must be met for effective use of the BMP;
  - (3) BMP installation/construction procedures, including typical drawings; and
  - (4) Operation and maintenance procedures for the BMP.
  
- i. Specific Instance of BMPs: The SWPPP shall provide the following information for each specific instance where a BMP is to be installed:
  - (1) Whether the BMP is temporary or permanent;
  - (2) Where, in relation to other site features, the BMP is to be located;
  - (3) When the BMP will be installed in relation to each phase of the land disturbance procedures to complete the project; and
  - (4) Site conditions that must be met before removal of the BMP if the BMP is not a permanent BMP.
  
- j. Disturbed Areas: Slopes for disturbed areas must be defined in the SWPPP. A site map or maps defining the sloped areas for all phases of the project must be included in the SWPPP.
  - (1) For soil disturbing activities that have temporarily ceased on any portion of the site and will not resume for a period exceeding 14 calendar days:
    - (a) The permittee shall construct BMPs to establish interim stabilization; and
    - (b) Stabilization must be initiated immediately and completed within 14 calendar days.
  - (2) For soil disturbing activities that have been permanently ceased on any portion of the site, final stabilization of disturbed areas must be initiated immediately and completed within 14 calendar days.
  - (3) Allowances to the 14 day completion period for temporary and final stabilization may be made due to weather and equipment malfunctions. In drought-stricken areas where initiating vegetative stabilization measures immediately are infeasible, alternative stabilization measures must be employed. The use of allowances shall be documented in the SWPPP.

- (4) Interim stabilization shall consist of well-established and maintained BMPs that are reasonably certain to protect waters of the state from sediment pollution over an extended period of time. This may require adding more BMPs to an area than is normally used during daily operations. These BMPs may include a combination of sediment basins, check dams, sediment fences and mulch. The types of BMPs used must be suited to the area disturbed, taking into account the number of acres exposed and the steepness of the slopes. If the slope of the area is greater than 3:1 (three feet horizontal to one foot vertical) or if the slope is greater than 3% and greater than 150 feet in length, then the permittee shall establish interim stabilization within seven days of ceasing operations on that part of the site.
  - (5) In limited circumstances, stabilization may not be required if the intended function of a specific area of the site necessitates that it remain disturbed.
- k. Installation: The permittee shall ensure the BMPs are properly installed at the locations and relative times specified in the SWPPP.
- (1) Peripheral or border BMPs to control runoff from disturbed areas shall be installed or marked for preservation before general site clearing is started. Note that this requirement does not apply to earth disturbances related to initial site clearing and establishing entry, exit and access of the site, which may require that stormwater controls be installed immediately after the earth disturbance.
  - (2) For phased projects, BMPs shall be properly installed as necessary prior to construction activities.
  - (3) Stormwater discharges from disturbed areas which leave the site shall pass through an appropriate impediment to sediment movement such as a sedimentation basin, sediment traps and/or silt fences prior to leaving the land disturbance site.
  - (4) A drainage course change shall be clearly marked on a site map and described in the SWPPP.
  - (5) If vegetative stabilization measures are being implemented, stabilization is considered "installed" when all activities necessary to seed or plant the area are completed.
- i. Sedimentation Basins: The SWPPP shall include a sedimentation basin for each drainage area with ten or more acres disturbed at one time.
- (1) The sedimentation basin shall be sized to a local 2-year, 24-hour storm. A 2-year, 24-hour storm event shall be determined for the project location using the National Oceanic and Atmospheric Administration's National Weather Service Atlas 14 which can be located at <http://hdsc.nws.noaa.gov/hdsc/pfds/>.
  - (2) Basins designed and initiated under the 2012 Area-Wide Land Disturbance General Permit MO-R100000 or prior authorizations shall comply with the requirements held in those authorizations. Any construction activities designed and initiated under this authorization shall comply with the local 2-year, 24-hour storm event by January 1, 2018.
  - (3) Accumulated sediment shall be removed from the basin when basin is 50% full.
  - (4) Utilize outlet structures that withdraw water from the surface when discharging from basins and impoundments unless infeasible.
  - (5) Discharges from the basin shall not cause scouring of the banks or bottom of the receiving stream.
  - (6) The SWPPP shall require the basin be maintained until final stabilization of the disturbed area served by the basin.
  - (7) The SWPPP shall require both temporary and permanent sedimentation basins to have a stabilized spillway to minimize the potential for erosion of the spillway or basin embankment.
  - (8) Where use of a sediment basin is infeasible, the SWPPP shall evaluate and specify other similarly effective BMPs to be employed to control erosion and sediment delivery. These similarly effective BMPs shall be selected from appropriate BMP guidance documents authorized by this permit. The BMPs must provide equivalent water quality protection to achieve compliance with this permit.

- m. Pollution Prevention Measures: The SWPPP shall include BMPs for pollution prevention measures. At minimum such measures must be designed, installed, implemented and maintained to:
    - (1) Minimize the discharge of pollutants from equipment and vehicle washing, wheel wash water, and other wash waters. Wash waters must be treated in a sediment basin or alternative control that provides equivalent or better treatment prior to discharge;
    - (2) Minimize the exposure of building materials, building products, construction wastes, trash, landscape materials, fertilizers, pesticides, herbicides, detergents, sanitary waste, and other materials present on the site to precipitation and to stormwater. Minimization of exposure is not required in cases where the exposure to precipitation and to stormwater will not result in a discharge of pollutants, or where exposure of a specific material or product poses little risk or stormwater contamination (such as final products and material intended for outdoor use);
    - (3) Minimize the discharge of pollutants from spills and leaks and implement chemical spill and leak prevention and response procedures. Included but not limited to the installation of containment berms and use of drip pans at petroleum product and liquid storage tanks and containers; and
  
  - n. Roadways: Where applicable, upon installation of or connection to roadways, all efforts should be made to prevent the deposition of earth and sediment onto roadways through the use of proper BMPs.
    - (1) Stormwater inlets susceptible to receiving sediment from the permitted land disturbance site shall have curb inlet protection.
    - (2) Where stormwater will flow off the end of where a roadway terminates, a sediment catching BMP such as gravel berm or silt fence shall be provided.
    - (3) Curb inlets shall be cleaned weekly or following a precipitation event that generates a run-off.
  
  - o. Dewatering: Discharges from dewatering activities, including discharges from dewatering of trenches and excavations, are prohibited unless managed by appropriate controls. The SWPPP shall include a description of any anticipated dewatering methods.
    - (1) The SWPPP shall call for specific BMPs designed to treat water pumped from trenches and excavations and in no case shall this water be pumped off-site without being treated by the specified BMPs.
11. Good housekeeping practices shall be maintained at all times to keep waste from entering waters of the state. Solid and hazardous waste management include providing trash containers and regular site cleanup for proper disposal of solid waste such as scrap building material, product/material shipping waste, and food containers and cups, and providing containers and proper disposal of waste paints, solvents and cleaning compounds. The provision of portable toilets for proper disposal of sanitary sewage and the storage of construction materials should be kept away from drainage courses and low areas.
12. All fueling facilities present shall at all times adhere to applicable federal and state regulations concerning underground storage, above ground storage and dispensers.
13. Hazardous substances that are transported, stored, or used for maintenance, cleaning, or repair shall be managed according to the provisions of the Missouri Hazardous Waste Laws and Regulations.
14. Containers: All paint, solvents, petroleum products, petroleum waste products and storage containers such as drums, cans, or cartons shall be stored according to BMPs. The materials exposed to precipitation shall be stored in watertight, structurally sound, closed containers. All containers shall be inspected for leaks or spillage during the inspection of BMPs.

15. Amending/Updating the SWPPP: The permittee shall amend and update the SWPPP as appropriate during the term of the land disturbance activity. The permittee shall amend the SWPPP at a minimum whenever the:
  - a. Design, operation, or maintenance of BMPs is changed;
  - b. Design of the construction project is changed that could significantly affect the quality of the stormwater discharges;
  - d. Department notifies the permittee in writing of deficiencies in the SWPPP;
  - e. SWPPP is determined to be ineffective in minimizing or controlling erosion and sedimentation (e.g., there is visual evidence of excessive site erosion or excessive sediment deposits in streams or lakes); and/or
  - f. Department determines violations of water quality standards may occur or have occurred.
  
16. An individual shall be designated by the permittee as the lead for environmental matters. The lead individual for environmental matters shall have a thorough and demonstrable knowledge of the site's SWPPP and sediment and erosion control practices in general. The lead individual for environmental matters or a designated inspector knowledgeable in erosion, sediment and stormwater control principles shall inspect all structures that function to prevent pollution of waters of the state
  
17. Site Inspections: The permittee (or a representative of the permittee) shall conduct regularly scheduled inspections.
  - a. These inspections shall be conducted by a qualified person, one who is responsible for environmental matters at the site, or a person trained by and directly supervised by the person responsible for environmental matters at the site.
  - b. Inspections are only required during the project's normal working hours.
  - c. For disturbed areas that have not been finally stabilized, all installed BMPs and other pollution control measures shall be inspected for proper installation, operation and maintenance.
  - d. Areas on-site that have been stabilized must be inspected at least once per month.
    - (1) For areas where disturbed portions have undergone temporary stabilization at the same time active construction continues on other areas, inspections shall occur at least once a month while stabilized and when re-disturbed shall follow either frequency outlined in subsection h. below.
    - (2) For areas where disturbed portions have undergone final stabilization at the same time active construction continues on other areas, inspection frequency may be cease on the finally stabilized areas according to the following:
      - (a) After the first monthly inspection, inspect once more within 24 hours of a storm event of 0.25 inches or greater.
      - (b) If there are no issues or evidence of stabilization problems, further inspections may cease.
      - (c) If unstable site conditions or sediment movement are observed, the site must be re-stabilized and monthly inspections shall occur until final stabilization is confirmed following a storm event of 0.25 inches or greater.
  - e. All stormwater outfalls shall be inspected for evidence of erosion or sediment deposition.
  - f. When practicable the receiving stream shall also be inspected for 50 feet downstream of the outfall.
  - g. Any structural or maintenance problems shall be noted in an inspection report and corrected as soon as possible but no more than seven calendar days after the inspection.
    - (1) If weather conditions prevent correction of BMPs within seven calendar days, the reasons for the delay must be documented (including pictures) and there must be a narrative explaining why the work cannot be accomplished within the seven day time period.
    - (2) The documentation must be filed with the regular inspection reports.
    - (3) The permittee shall correct the problem as soon as weather conditions allow.
  - h. All BMPs must be inspected in accordance to one of the two schedules listed below, and any

changes to the frequency of inspections, including switching between the options listed below, must be documented in the SWPPP:

- (1) At least once every seven calendar days and within 48 hours after any storm event equal to or greater than a 2-year, 24-hour storm has ceased during a normal work day and within 72 hours if the event ceases during a non-work day such as a weekend or holiday;  
or
  - (2) Once every 14 calendar days and within 24 hours of the occurrence of a storm event of 0.25 inches or greater or the occurrence of runoff from snowmelt. To determine if a storm event of 0.25 inches or greater has occurred on-site, the permittee must either keep a properly maintained precipitation gauge on site, or obtain the storm event information from a weather station near the site.
    - (a) Inspections shall be conducted within 24 hours once a storm event has produced 0.25 inches within a 24 hour period; even if the storm event is still continuing.
    - (b) If the permittee has elected to inspect every 14 calendar days and there is a storm event at the site that continues for multiple days, and each day of the storm produces 0.25 inches or more of rain, the permittee is required to conduct an inspection within 24 hours of the first day of the storm and within 24 hours after the end of the storm.
18. The SWPPP must explain how the person responsible for erosion control will be notified when stormwater runoff occurs
19. Site Inspections Reports: A log of each inspection and copy of the inspection report shall be kept readily accessible and must be available upon request by the department. Electronic logs are acceptable as long as reports can be provided in a timely manner. If inspection reports are kept off-site, the SWPPP must indicate where they are stored. The inspection report shall be signed by the permittee or by the person performing the inspection if duly authorized to do so. The inspection report is to include the following minimum information:
- a. Inspector's name;
  - b. Date of inspection;
  - c. Observations relative to the effectiveness of the BMPs;
  - d. Actions taken or necessary to correct the observed problem; and
  - e. Listing of areas where land disturbance operations have permanently or temporarily stopped.
20. Notification to All Contractors: The permittee shall be responsible for notifying each contractor or entity (including utility crews and city employees or their agents) who will perform work at the site of the existence of the SWPPP and what action or precautions shall be taken while on-site to minimize the potential for erosion and the potential for damaging any BMP. The SWPPP shall contain a record of notification; for example, a list of contractors or entities given a copy of the SWPPP or education session sign-in sheet. The permittee is responsible for any damage a subcontractor may do to established BMPs and any subsequent water quality violation resulting from the damage.
21. Public Notification: The permittee shall post a copy of the public notification sign on page 15 of this permit at the main entrance to the site. The public notification sign must be visible from the public road that provides access to the site's main entrance. An alternate location is acceptable provided the public can see it and it is noted in the SWPPP. The public notification sign must remain posted at the site until the permit has been terminated.

## OTHER DISCHARGES

A record of each reportable release of hazardous substance shall be retained with the SWPPP and made available to the department upon request. The department may also require the submittal of a written or electronic report detailing measures taken to clean up the spill within five (5) days of the spill. Such a report must include the type of material spilled, volume, date of spill, date clean-up was completed, clean-up method, and final disposal method.

## SAMPLING REQUIREMENTS AND EFFLUENT LIMITATIONS

The department may require sampling and reporting as a result of illegal discharges, compliance issues, complaint investigations, or other such evidence of contamination from activities at the site. If such an action is needed, the department will specify in writing any sampling requirements, including such information as location, extent and parameters.

## RECORDS

1. The permittee shall retain copies of this general permit, the SWPPP and all amendments for the site, results of any monitoring and analysis, and all site inspection records. The records shall be accessible during normal business hours. The records shall be retained for a period of at least three years from the date of the Letter of Termination.
2. The permittee shall provide a copy of the SWPPP to the department, USEPA, or any local agency or government representative if they request a copy in the performance of their official duties.
3. The permittee shall provide a copy of the SWPPP to those who are responsible for installation, operation, or maintenance of any BMP. The permittee, their representative, and/or the contractor(s) responsible for installation, operation and maintenance of the BMPs shall have a current copy of the SWPPP with them when on the project site.

## LAND PURCHASE AND CHANGE OF OWNERSHIP

1. If the permittee sells any portion of the permitted site to a developer for commercial, industrial, or residential use, this land remains a part of the common sale and the new owner must obtain a permit prior to conducting any land disturbance activity. Therefore, the original permittee must amend the SWPPP to show that the property has been sold and therefore no longer under the original permit coverage.
2. Property of any size which is part of a larger common plan of development where the property has been stabilized and the original permit terminated will require application of a new land disturbance permit for any future land disturbance activity unless exempted per 10 CSR 20-6.010(1)(B), 10 CSR 20-6.200(1)(B), and 40 CFR 122.26(a)(2)(ii).
3. If the entire tract is sold to a single entity, then this permit shall be terminated when the new owner obtains a new land disturbance permit for the site.
4. If a portion of a larger common plan of development is sold to an individual for the purpose of building his or her own private residence, a permit is required if the portion of land sold is equal to or greater than one acre while no permit is required for less than one acre of land sold.

## TERMINATION

This permit may be terminated when all projects are stabilized. The project is considered to be finally stabilized when perennial vegetation, pavement, buildings, or structures using permanent materials cover all areas that have been disturbed. With respect to areas that have been vegetated, vegetation cover shall be at least 70% over 100% of the site. In order to terminate the permit, the permittee shall notify the department by submitting *Form H- Request for Termination of a General Permit* (<http://dnr.mo.gov/forms/780-1409-f.pdf>).

## DUTY TO REAPPLY

Unless terminated, the permittee shall submit an application for the renewal of this permit by submitting *Form E-Application for General Permit* (<http://dnr.mo.gov/forms/780-0795-f.pdf>) and

*Form G – Application for Stormwater Permit Under the General Permit: Land Disturbance* (<http://dnr.mo.gov/forms/780-1408-f.pdf>) no later than thirty (30) days prior to the permit's expiration date. If a facility submits a timely and complete application in accordance with 10 CSR 20-6.010(5)(B), (5)(C), and (10)(E)1, as well as § 644.051.10, RSMo 2015, if the department is unable, through no fault of the permittee, to issue a renewal prior to expiration of the previous permit, the terms and conditions of the expired permit are administratively continued and will remain fully effective and enforceable until such time when a permit action is taken. Failure to submit a renewal application for a facility that is still in operation is a violation of the Missouri Clean Water Law. As part of the complete application and as required by the federal NPDES eReporting rule, participation in the department's Electronic Discharge Monitoring Report Submission System (eDMR) will be required. Facilities already participating in eDMR need not re-apply upon renewal. More information can be found at: <http://dnr.mo.gov/env/wpp/edmr.htm>. Failure to apply for renewal of a permit may result in termination of this permit and enforcement action to compel compliance with this condition and the Missouri Clean Water Law. This permit may be applied for and issued electronically once made available by the director in accordance with Section 644.051.10, RSMo.

#### MODIFICATION, REVOCATION, AND REOPENING

1. The full implementation of this operating permit shall constitute compliance with all applicable federal and state statutes and regulations in accordance with §644.051.16, RSMo, and the CWA section 402(k); however, this permit may be reopened and modified, or alternatively revoked and reissued to comply with any applicable effluent standard or limitation issued or approved under Sections 301(b)(2)(C) and (D), 304(b)(2), and 307(a) (2) of the Clean Water Act, if the effluent standard or limitation so issued or approved:
  - a. contains different conditions or is otherwise more stringent than any effluent limitation in the permit; or
  - b. controls any pollutant not limited in the permit.
2. If this permit is reopened, modified or revoked pursuant to this Section, the permittee retains all rights under Chapter 536 and 644 Revised Statutes of Missouri upon the department's reissuance of the permit as well as all other forms of administrative, judicial, and equitable relief available under law.

#### STANDARD CONDITIONS

These Standard Conditions incorporate permit conditions as required by 40 CFR 122.41 or other applicable state statutes or regulations. These minimum conditions apply unless superseded by requirements specified in the permit.

1. Other Information: Where the permittee becomes aware that it failed to submit any relevant facts in a permit application, or submitted incorrect information in a permit application or in any report to the department, it shall promptly submit such facts or information.
2. Duty to Comply: The permittee must comply with all conditions of this permit. Any permit noncompliance constitutes a violation of the Missouri Clean Water Law and Federal Clean Water Act and is grounds for enforcement action; for permit termination, revocation and reissuance, or modification; or denial of a permit renewal application.
3. Duty to Provide Information: The permittee shall furnish to the department, within a reasonable time, any information which the department may request to determine whether cause exists for modifying, revoking and reissuing, or terminating this permit or to determine compliance with this permit. The permittee shall also furnish to the department upon request, copies of records required to be kept by this permit.

4. Inspection and Entry: The permittee shall allow the department, or an authorized representative (including an authorized contractor acting as a representative of the department), upon presentation of credentials and other documents as may be required by law, to:
  - a. Enter upon the permittee's premises where a regulated facility or activity is located or conducted, or where records must be kept under the conditions of the permit;
  - b. Have access to and copy, at reasonable times, any records that must be kept under the conditions of this permit;
  - c. Inspect at reasonable times any facilities, equipment (including monitoring and control equipment), practices, or operations regulated or required under this permit; and
  - d. Sample or monitor at reasonable times, for the purposes of assuring permit compliance or as otherwise authorized by the Federal Clean Water Act or Missouri Clean Water Law, any substances or parameters at any location.
  
5. Signatory Requirement:
  - a. All permit applications, reports required by the permit, or information requested by the department shall be signed and certified. (See 40 CFR 122.22 and 10 CSR 20-6.010)
  - b. The Federal Clean Water Act provides that any person who knowingly makes any false statement, representation, or certification in any record or other document submitted or required to be maintained under this permit, including monitoring reports or reports of compliance or non-compliance shall, upon conviction, be punished by a fine of not more than \$10,000 per violation, or by imprisonment for not more than six (6) months per violation, or by both.
  - c. The Missouri Clean Water Law provides that any person who knowingly makes any false statement, representation or certification in any application, record, report, plan, or other document filed or required to be maintained pursuant to sections 644.006 to 644.141 shall, upon conviction, be punished by a fine of not more than ten thousand dollars, or by imprisonment for not more than six months, or by both.

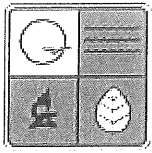

Missouri  
Department of  
Natural Resources

STORMWATER DISCHARGES  
FROM THIS LAND DISTURBANCE  
SITE ARE AUTHORIZED BY THE  
MISSOURI STATE OPERATING  
PERMIT NUMBER:

---

ANYONE WITH QUESTIONS OR  
CONCERNS ABOUT  
STORMWATER DISCHARGES  
FROM THIS SITE, PLEASE  
CONTACT THE MISSOURI  
DEPARTMENT OF NATURAL  
RESOURCES AT

**1-800-361-4827**

**Missouri Department of Natural Resources**  
**Fact Sheet**  
**MO-R100000**

The Federal Water Pollution Control Act [Clean Water Act (CWA)] Section 402 of Public Law 92-500 (as amended) established the National Pollution Discharge Elimination System (NPDES) permit program. This program regulates the discharge of pollutants from point sources into the waters of the United States, and the release of stormwater from certain point sources. All such discharges are unlawful without a permit (Section 301 of the CWA). After a permit is obtained, a discharge not in compliance with all permit terms and conditions is unlawful. Missouri State Operating Permits (permit) are issued by the Missouri Department of Natural Resources (department) under an approved program, operated in accordance with federal and state laws (Federal CWA and Missouri Clean Water Law Section 644 as amended). Permits are issued for a period of five (5) years unless otherwise specified.

Per 40 CFR 124.56, 40 CFR 124.8, and 10 CSR 20-6.020(1)(A)2., a Fact Sheet shall be prepared to give pertinent information regarding the applicable regulations, rationale for the development of effluent limitations and conditions, and the public participation process for the permit. A Fact Sheet is not an enforceable part of a permit.

This Fact Sheet is for a:

- Major
- Minor
- Industrial Facility
- Variance
- Master General Permit
- Permit with widespread public interest

**Definitions**

**Common Promotional Plan:** A plan undertaken by one (1) or more persons, to offer lots for sale or lease; where land is offered for sale by a person or group of persons acting in concert, and the land is contiguous or is known, designated or advertised as a common unit or by a common name or similar names, the land is presumed, without regard to the number of lots covered by each individual offering, as being offered for sale or lease as part of a common promotional plan.

**Immediately:** For the purposes of this permit, immediately should be defined as within 24 hours.

**Infeasible:** Infeasible means not technologically possible, or not economically practicable and achievable in light of best industry practices.

**Larger Common Plan of Development or Sale:** A contiguous area where multiple separate and distinct construction activities are occurring under one plan.

**Non-structural Best Management Practice:** Institutional, educational or pollution prevention practices designed to limit the amount of stormwater runoff or pollutants that are generated in the landscape. An example includes ordinance development.

**Ordinary High Water Mark:** The line on the shore established by fluctuations of water and indicated by physical characteristics such as a clear, natural line impressed on the bank, shelving, changes in the character of soil, destruction of terrestrial vegetation and/or the presence of litter and debris.

**Peripheral:** For the purposes of this permit, peripheral should be defined as the outermost boundary of the area that will be disturbed.

**Permanently:** For the purposes of this permit, permanently should be defined as any activity that has been

ceased without any intentions of future disturbance.

Structural Best Management Practice: Physical controls working individually or as a group, appropriate to the source, location, and area climate for the pollutant to be controlled. Examples include moving earth for sedimentation basin and planting vegetation.

Waters of the state: Section 644.016.1(27), RSMo defines waters of the state as, "All waters within the jurisdiction of this state, including all rivers, streams, lakes and other bodies of surface and subsurface water lying within or forming a part of the boundaries of the state which are not entirely confined and located completely upon lands owned, leased or otherwise controlled by a single person or by two or more persons jointly or as tenants in common."

### **Part I – Facility Information**

Facility Type: Industrial Stormwater  
Facility Description: Construction or land disturbance activity (e.g., clearing, grubbing, excavating, grading, filling, and other activities that result in the destruction of the root zone and/or land disturbance activity that is reasonably certain to cause pollution to waters of the state).

This permit establishes a SWPPP requirement to minimize pollutants of concern from this type of facility or for all facilities covered under this permit. 10 CSR 20-6.200(6)(A)7. specifies that "general permits shall contain BMP requirements and/or monitoring and reporting requirements to keep the stormwater from becoming contaminated." Local conditions are not considered when developing conditions for a general permit. A facility may apply for a site-specific permit if they desire a review of local conditions.

While drafting this permit for renewal, the department hosted four public meetings on January 27, February 24, April 18, and May 19, 2016, which allowed stakeholders to voice concerns about conditions within the permit and submit comments during the period of initial involvement. These concerns were taken into consideration when drafting the permit.

### **Part II – Receiving Stream Information**

#### **APPLICABLE DESIGNATIONS OF WATERS OF THE STATE:**

Per Missouri Effluent Regulations (10 CSR 20-7.015), the waters of the state are divided into seven (7) categories. This permit applies to facilities discharging to the following water body categories:

Please mark all appropriate designated waters of the state categories of the receiving stream.

- Missouri or Mississippi River [10 CSR 20-7.015(2)]
- Lakes or Reservoirs [10 CSR 20-7.015(3)]
- Losing Streams [10 CSR 20-7.015(4)]
- Metropolitan No-Discharge Streams [10 CSR 20-7.015(5)]
- Special Streams [10 CSR 20-7.015(6)]
- Subsurface Waters [10 CSR 20-7.015(7)]
- All Other Waters [10 CSR 20-7.015(8)]

Missouri Water Quality Standards (10 CSR 20-7.031) defines the Clean Water Commission water quality objectives in terms of "water uses to be maintained and the criteria to protect those uses." The receiving stream and/or 1<sup>st</sup> classified receiving stream's beneficial water uses shall be maintained in accordance with 10 CSR 20-7.031(4). The BMP requirement established by this permit are intended to be protective of all streams that fall within the categories of receiving water bodies indicated above. A general permit does not take into consideration site-specific conditions.

### **Part III – Applicability**

Condition number 5 includes support activities. Those support activities are to become part of the land disturbance permitted area and included in the acreage calculations, whether the support activities are located adjacent to, on-site or off-site from the main land disturbance construction area. For example, if the main land disturbance site is 0.6 acres and the project needs fills that is gathered from a borrow site specific to this project which equals 0.5 acres, then the total acreage for this project is an acre or more and the conditions of this permit apply to both the main construction area and the borrow area.

Condition number 14 was expanded to include a more comprehensive list of state and federal requirements that must be taken into consideration.

If the proposed project encounters and will potentially affect a species of concern, please report it to the Missouri Department of Conservation and the United States Fish and Wildlife Service. For more information about requirements of the Endangered Species Act, please visit the following links:

1. To determine the potential for species of concern within or near a project, please visit the United States Fish and Wildlife Services' "Information, Planning and Conservation" website at <http://ecos.fws.gov/ipac/>.
2. If there are listed species in the county or township, check to see if critical habitat has been designated and if that area overlaps or is near the project area. Critical habitat designations and associated requirements may also be found at 50 CFR Parts 17 and 226. For additional information, use the map view tool at <http://criticalhabitat.fws.gov/crithab/> to find data specific to the state and county.

The Missouri Department of Conservation's internet site for the Natural Heritage Review may be very helpful and can be found at the following link, <https://naturalheritagereview.mdc.mo.gov/>.

### **Part IV – Exemptions**

Condition Number 2 was added to cite all state exemptions from permitting requirements, combining several previous cited exemptions into one condition and reference. This includes an exemption for linear construction where the entire disturbance, including clearing of land to access the linear disturbance, is less than two feet in width.

Condition Number 3 was added to cite federal regulations that exclude land disturbance projects related to the installation or maintenance work for oil and gas related activities.

### **Part V – Rationale of Technology Based Limitations & Permit Conditions**

#### **303(d) LIST & TOTAL MAXIMUM DAILY LOAD (TMDL):**

Section 303(d) of the Federal CWA requires that each state identify waters that are not meeting Water Quality Standards and for which adequate water pollution controls have not been required. Water Quality Standards protect such beneficial uses of water as whole body contact, maintaining fish and other aquatic life, and providing drinking water for people, livestock, and wildlife. The 303(d) list helps state and federal agencies keep track of waters that are impaired but not addressed by normal water pollution control programs.

#### **ANTI-BACKSLIDING:**

A provision in the Federal Regulations [CWA Section 303(d) (4); CWA Section 402(c); 40 CFR Part 122.44(I)] that requires a reissued permit to be as stringent as the previous permit with some exceptions.

- Applicable: Backsliding proposed in this permit conforms to the anti-backsliding provisions of Section 402(o) of the CWA and 40 CFR 122.44. The department has determined that technical mistakes were made in the previous permit [CWA 402(o)(2)(B)(ii)]. The Department has determined that technical mistakes or mistaken interpretations of law were made in issuing the

permit under section 402(a)(1)(b).

**Settleable Solids:** The Settleable Solids limitation was removed since has been determined to not be a statewide technology or water quality based limitation given a variability of soil type in the state. Increased technology based best management practices have been included and are a more appropriate technology based requirement.

**Water Quality Standard Narrative Prohibitions.** The previous permit contained language which referenced narrative compliance with the water quality standards found in 10 CSR 20-7.031. In order to comply with 40 CFR 122.44(d)(1), the permit writer has conducted reasonable potential determinations for each general and applicable specific criterion and established numeric effluent limitations where reasonable potential exists. While the removal of the previous permit language creates the appearance of backsliding, the permit writer has evaluated discharges associated with this general permit as to whether reasonable potential to cause excursions of specific or general criteria on a statewide level and found that no reasonable potential exists given the proper implementation of a Stormwater Pollution Prevention Plan and associated best management practices and that the requirements of this permit are equally protective as compared to the previous permit. Therefore, given this new information, and the fact that the previous permit special condition was not consistent with 40 CFR 122.44(d)(1), an error occurred in the establishment of the general criteria as a special condition of the previous permit.

**ANTIDEGRADATION:**

Antidegradation policies ensure protection of water quality for a particular water body on a pollutant by pollutant basis to ensure Water Quality Standards are maintained to support beneficial uses such as fish and wildlife propagation and recreation on and in the water. This also includes special protection of waters designated as an Outstanding National Resource Water or Outstanding State Resource Water [10 CSR 20-7.031(3) (C)]. Antidegradation policies are adopted to minimize adverse effects on water. The department has determined that the best avenue forward for implementing the Antidegradation requirements into general permits is by requiring the appropriate development and maintenance of a SWPPP. The SWPPP must identify all Best Management Practices (BMPs) that are reasonable and effective, taking into account environmental impacts and costs. This analysis must document why no discharge or no exposure options are not feasible at the facility. This selection and documentation of appropriate control measures will then serve as the analysis of alternatives and fulfill the requirements of the Antidegradation Rule and Implementation Procedure 10 CSR 20-7.031(3) and 10 CSR 20-7.015(9)(A)5.

Any facility seeking coverage under this permit, which undergoes expansion or discharges a new pollutant of concern, must update their SWPPP and select new BMPs that are reasonable and cost effective. New facilities seeking coverage under this permit are required to develop a SWPPP that includes this analysis and documentation of appropriate BMPs. Renewal of coverage for a facility requires a review of the SWPPP to assure that the selected BMPs continue to be appropriate.

- Applicable:** The main pollutant of concern in this permit is sediment. Compliance with the technology-based limitations established in this permit for the protection of General Criteria, along with the evaluation and implementation of BMPs as documented in the SWPPP, meets the requirements of Missouri's Antidegradation Review [10 CSR 20-7.031(3), 10 CSR 20-7.031 Table A, and 10 CSR 20-7.015(9)(A)5].

**STORMWATER POLLUTION PREVENTION PLAN (SWPPP):**

In accordance with 40 CFR 122.44(3)(k) Best Management Practices (BMPs), BMPs are implemented to control or abate the discharge of pollutants when: (1) Authorized under Section 304(e) of the CWA for the control of toxic pollutants and hazardous substances from ancillary industrial activities; (2) Authorized under Section 402(p) of the CWA for the control of stormwater discharges; (3) Numeric effluent limitations are infeasible; or (4) The practices are reasonably necessary to achieve effluent limitations and standards or to carry out the purposes and intent of the CWA.

In accordance with Developing Your Stormwater Pollution Prevention Plan, a Guide for Construction Sites (EPA 833-R-06-004; [https://www3.epa.gov/npdes/pubs/sw\\_swppp\\_guide.pdf](https://www3.epa.gov/npdes/pubs/sw_swppp_guide.pdf)) published by the United States Environmental Protection Agency (EPA) in May 2007, BMPs are measures or practices used to reduce the amount of pollution entering waters of the state. BMPs may take the form of a process, activity, or physical structure. EPA developed resources and tools related to construction stormwater along with the BMPs to control and minimize stormwater ( <https://www.epa.gov/npdes/stormwater-discharges-construction-activities>). Along with EPA's resources and tools, the International Stormwater BMP database ([www.bmpdatabase.org/index.htm](http://www.bmpdatabase.org/index.htm)) may provide guidance on BMPs appropriate for specific industries.

Additionally in accordance with Stormwater Management, a SWPPP is a series of steps and activities to (1) identify sources of pollution or contamination, and (2) select and carry out actions which prevent or control the pollution of stormwater discharges.

- Applicable: A SWPPP shall be developed and implemented for each site and shall incorporate required practices identified by the department with jurisdiction, incorporate erosion control practices specific to site conditions, and provide for maintenance and adherence to the plan.

The new permit has been revised to allow permittees to store SWPPP documents electronically as long as they can be provided in an expedient manner.

Release of a hazardous substance must be reported to the department in accordance with 10 CSR 24-3.010. If the spill occurs outside of normal business hours, or if the permit holder cannot reach regional office staff for any reason, the permit holder is instructed to report the spill to the department's 24 hour Environmental Emergency Response hotline at (573) 634-2436 at the earliest practicable moment after discovery. Leaving a message on a department staff member voice-mail does not satisfy this reporting requirement.

#### **WATER QUALITY STANDARDS:**

Per 10 CSR 20-7.031(4), General Criteria shall be applicable to all waters of the state at all times, including mixing zones. Additionally, 40 CFR 122.44(d)(1) directs the department to include in each NPDES permit conditions to achieve water quality established under Section 303 of the CWA, including state narrative criteria for water quality.

#### **SPECIFIC CRITERIA CONSIDERATIONS:**

An evaluation of discharges associated with land disturbance activities has been conducted to determine if any pollutants discharged under this general permit would have reasonable potential to cause or contribute toward an excursion of specific water quality criterion. Pollutants discharged from land disturbance activities are not commonly associated with pollutants listed as specific criteria in the Missouri Water Quality Standards; therefore, reasonable potential to cause an excursion of a specific criterion does not exist.

#### **GENERAL CRITERIA CONSIDERATIONS:**

In accordance with 40 CFR 122.44(d)(1), effluent limitations shall be placed into the permit for those pollutants which have been determined to cause, have the reasonable potential to cause, or contribute to an excursion above any State water quality standard, including State narrative criteria for water quality. The rule further states that pollutants which have been determined to cause, have the reasonable potential to cause, or contribute to an excursion above a narrative criterion within an applicable State water quality standard, the permit shall contain a numeric effluent limitation to protect that narrative criterion. In order to comply with this regulation, the permit writer will complete reasonable potential determinations on whether the discharge will violate any of the general criteria listed in 10 CSR 20-7.031(4). These specific requirements are listed below followed by derivation and discussion [the lettering matches that of the rule itself, under 10 CSR 20-7.031(4)]. It should also be noted that Section 644.076.1, RSMo states that it shall be unlawful for any person to cause or permit any discharge of water contaminants from any water contaminant or point source located in Missouri that is in violation of sections 644.006 to 644.141 of the Missouri Clean Water Law or any

standard, rule or regulation promulgated by the commission.

- (a) Waters shall be free from substances in sufficient amounts to cause the formation of putrescent, unsightly or harmful bottom deposits or prevent full maintenance of beneficial uses. The SWPPP requires implementation of best management practices to store, prevent, or minimize stormwater and/or any related land disturbance activity discharges (namely sediment). If one follows their SWPPP and other permit conditions including timely inspections, no reasonable potential to cause an excursion of this narrative exists. Additionally, there had been no indication to the Department that a stream has had issues maintaining beneficial uses as a result of the controlled and managed stormwater discharges per the SWPPP. Therefore, based on the information reviewed during the drafting of this permit, no reasonable potential to cause or contribute to an excursion of this criterion exists.
- (b) Waters shall be free from oil, scum and floating debris in sufficient amounts to be unsightly or prevent full maintenance of beneficial uses. Please see (a) above as justification is the same.
- (c) Waters shall be free from substances in sufficient amounts to cause unsightly color or turbidity, offensive odor or prevent full maintenance of beneficial uses. Please see (a) above as justification is the same.
- (d) Waters shall be free from substances or conditions in sufficient amounts to result in toxicity to human, animal or aquatic life. This permit addresses discharges from land disturbance activities and it not expected to include an toxic pollutants. Best management practices are to be addressed in the SWPPP should any toxic pollutant of concern be on-site.
- (e) There shall be no significant human health hazard from incidental contact with the water. Please see (a) above as justification is the same.
- (f) There shall be no acute toxicity to livestock or wildlife watering. Please see (d) above as justification is the same.
- (g) Waters shall be free from physical, chemical or hydrologic changes that would impair the natural biological community. Please see (a) above as justification is the same.
- (h) Waters shall be free from used tires, car bodies, appliances, demolition debris, used vehicles or equipment and solid waste as defined in Missouri's Solid Waste Law, section 260.200, RSMo, except as the use of such materials is specifically permitted pursuant to section 260.200-260.247. Please see (a) above. Additionally, any solid wastes received or produced at this facility are wholly contained in appropriate storage facilities, are not discharged, and are disposed of offsite. Therefore, this discharge does not have reasonable potential to cause or contribute to an excursion of this criterion.

The settleable solids requirement was removed from this permit and was replaced with additional, more specific BMP requirements. The settleable solids limit was determined not to be protective of all waters across the state, therefore, it was removed. Examples of these BMPs include requirements to:

- Install and maintain perimeter controls along areas of the site that will receive pollutant discharges;
- Minimize sediment track-out from the site;
- Provide storage for runoff up to and including a 2-year, 24-hour storm event when designing sedimentation basins; and
- Direct stormwater to vegetated areas.

The minimum buffer width was increased from 25 feet to 50 feet. Studies have shown that a 50 foot vegetative buffer more adequately treats sediment from stormwater discharges. This appears to be standard in EPA's permit as well as in many other states. A literature review was conducted to assess the effectiveness of buffer widths in relation to sediment removal. In an early literature review on grass buffers in agricultural settings, Dosskey (2001) concluded that 40 -100% of sediment entering from cultivated fields was removed using buffer strips 0.5 to 20 meters. Liu *et al.* (2008) conducted an analysis of 85 estimates of sediment removal by vegetated buffers. They found that sediment removal efficiency ( $E_s$ , the percentage of inflowing sediment trapped within a buffer) increased with buffer width according to the relationship:  $E_s = 13.4 \log_e (w) + 56.9$  in

which  $w$  (m) is buffer width. This equation predicts that  $E_s$  increases from 78% for a 5 meter wide buffer to 88% and 97% at widths of 10 meters and 20 meters, respectively. Yaun *et al.* (2009; 93 estimates) and Zhang *et al.* (2010; 81 estimates) garnered similar results to Liu *et al.*

In order to design controls that match the sediment removal efficiency of a 50-foot buffer, first the permittee must know what this efficiency is for the site. The sediment removal efficiencies of natural buffers vary according to a number of site-specific factors, including precipitation, soil type, land cover, slope length, width, steepness, and the types of sediment controls used to reduce the discharge of sediment prior to the buffer.

Sediment removal efficiencies are based on the U.S. Department of Agriculture's RUSLE2 (Revised Universal Soil Loss Equation 2) model for slope profiles using a 100-foot long exposed slopes.

Sediment removal is defined as the annual sediment delivered at the downstream end of the 50-foot natural buffer (tons/yr/acre) divided by the annual yield from cleared area (tons/yr/acre).

Sediment removal is in part a function of (1) a perimeter control (i.e., silt fence) located between the disturbed portion of the site and the upland edge of the natural buffer and (2) stormwater flows traveling through a 50-foot buffer of undisturbed natural vegetation.

Additional guidance may be found at [https://www.epa.gov/sites/production/files/2017-02/documents/2017\\_cgp\\_final\\_appendix\\_g\\_-\\_buffer\\_reqs\\_508.pdf](https://www.epa.gov/sites/production/files/2017-02/documents/2017_cgp_final_appendix_g_-_buffer_reqs_508.pdf).

Inspection frequencies: Site inspection frequencies have been changed from the previous permit based upon guidance from the USEPA and from stakeholder discussions. These frequencies will allow flexibility but will still allow for frequent enough inspections to ensure that all BMPs are adequately functioning.

## **Part VI – Effluent Limitations Determination**

In this general permit, Technology-Based Effluent Limitations are established through the SWPPP and BMP requirements. Effective BMPs may have to be designed on a site-specific basis. The implementation of monitoring provides a tool for each facility to evaluate the effectiveness of BMPs to ensure protection of water quality.

## **Part VII – Land Purchase and Change of Ownership**

A “larger common plan of development or sale” is a contiguous area where multiple separate and distinct construction activities may be taking place at different times on different schedules under one plan. This term is used in conjunction with common promotional plan, as defined in §644, RSMo.

Any portion of a project that is sold to a developer is still considered part of a larger common plan of development or sale and will require a permit.

If a portion of a site is sold to an individual for the purpose of building his or her private residence:

- A permit is required if the portion of land sold is equal to or greater than one acre.
- A permit is not required if the portion of land sold is less than one acre.

## **Part VIII – Termination**

The word ‘plant density’ was removed from the first paragraph since the department determined that percent of vegetative cover more accurately describes the vegetative requirements of this permit. This decision was made after discussion within the department and with stakeholders.

It is preferable that temporary BMPs such as sediment fence be removed prior to permit termination to

eliminate potential solid waste issues that may occur as a result of unnecessary and unmaintained BMPs.

Additional options for winter site stabilization as part of the vegetation requirement may exist, such as using a seeded erosion control blanket.

### **Part IX – Duty to Reapply**

This section has been revised to reflect the current applicable statutes which require applicants to submit an application for coverage 30 days prior to expiration of this permit. Currently, a paper application is required; however, applicants are to submit an application for coverage electronically as soon as they are made available by the director. The department will announce the availability status of the new permit and the process to reapply at least 60 days prior to the expiration of the existing permit.

### **Part X – Standard Conditions**

This section was revised to only include the standard conditions that specifically apply to this permit. All other conditions have been removed.

### **Part XI – Administrative Requirements**

On the basis of preliminary staff review and applicable standards and regulations, the department, as administrative agent for the Missouri Clean Water Commission, proposes to issue a permit(s) subject to certain effluent limitations, schedules, and special conditions contained herein and within the permit. The proposed determinations are tentative pending public comment.

#### **PUBLIC NOTICE:**

The department shall give public notice that a draft permit has been prepared and its issuance is pending. Additionally, public notice will be issued if a public hearing is to be held because of a significant degree of interest or because of water quality concerns related to a draft permit. No public notice is required when a request for a permit modification or termination is denied; however, the requester and facility must be notified of the denial in writing.

The department must give public notice of a pending permit or of a new or reissued Missouri State Operating Permit. The public comment period is a length of time not less than thirty (30) days following the date of the public notice, during which interested persons may submit written comments about the proposed permit.

For persons wanting to submit comments regarding this proposed permit, please refer to the Public Notice page located at the front of this draft permit. The Public Notice page gives direction on how and where to submit appropriate comments.

- The Public Notice period seeking comments on this permit occurred from March 31 to May 1, 2017.

**DATE OF FACT SHEET:** 06/16/2017

**COMPLETED BY:**  
**CHRISTOPHER MILLER**  
**ENVIRONMENTAL SPECIALIST**  
**573-526-3337**  
**christopher.miller@dnr.mo.gov**

**EDITED BY:**  
**STACIA BAX**  
**ENVIRONMENTAL SUPERVISOR**  
**573-526-4586**  
**stacia.bax@dnr.mo.gov**

# Storm Water Pollution Prevention Plan



**Cole County, Missouri  
Unincorporated Areas**

July 2012

## **Site Description**

**COLE COUNTY** is located in central Missouri. It is bordered on the east by Osage County, the north by the Missouri River, the west by Moniteau County and the south by Miller County.

### **Population and Land Use**

Cole County is 250,240 acres in size with an unincorporated urbanized area of 5,346 Acres. The county has a population of 72,757. The largest city is Jefferson City, with a population of 39,636. Approximately 8,796 people live in the urbanized area of unincorporated Cole County. (US Census, 2000).

Jefferson City is the home of the Lincoln University with 3,349 students. Other towns in Cole County include Wardsville (1,506), St. Martins (1,140), Taos (878), Russellville (807), Centertown (278), St. Thomas (263), and Lohman (163). (US Census 2010).

According to the 2007 US Agriculture Census, there are over 1,100 farms in Cole County with an average size of 164 acres. The total land used for farming is almost 180,840 acres.

### **Water Supply**

Missouri-American Water Company – Missouri River; Cole County Public Water Supply District 1 – Wells; Cole County Public Water Supply District 2 – Wells; Cole County Water Supply District 3 – Wells; and Privately Owned Wells

### **Waste Water Treatment**

City of Jefferson – Treatment Plant; Aqua-Missouri – Lagoons and Small Treatment Plants; and Individual On-Site Septic Systems

### **Watershed**

North Moreau Creek to Moreau River to Missouri River; Grays Creek to Missouri River; and Wears Creek to Missouri River

### **Geologic Setting**

Northern Edge of the Ozark Plateau – Bedrock is shallow bedded consisting of Ordovician carbonates

### **Average Rainfall**

39.59 inches per year

## **Manufacturing**

The County has the following manufacturing plants located with the urbanized areas:

1. Capital Quarries – Limestone Quarry Operations
2. Menu Maker Foods, Inc. – Food Packaging
3. Wren Enterprises – Security Hardware
4. J C Mattress Factory – Bedding Manufacturing

## **Best Management Practices**

### **Temporary and Permanent Structural and Non-Structural BMPs**

See Appendix A for a table outlining the temporary and permanent structural and non-structural best management practices that may be used in land disturbance activities.

### **Description of Best Management Practices**

See Appendix B for descriptions of the best management practices that may be used in land disturbance activities.

### **Discharges to Valuable Resource Waters**

Storm water discharges as described below shall be considered discharges to “valuable resource waters” and will not be allowed to have Total Settleable Solids in excess of 0.5 mg/L/hr.

- Storm water discharges within 1000 stream feet of:
  - Streams identified as a losing stream
  - Streams or lakes listed as an outstanding national or state resource water
  - Reservoirs or lakes used for public drinking water supplies
  - Streams, lakes, or reservoirs identified as critical habitat of endangered species
  - Streams, lakes, or reservoirs listed as impaired for sediment and/or unknown pollutants by standard MDNR methodology
- Storm water discharges:
  - Within 100 stream feet of a permanent stream (class P) or major reservoir (class L2)
  - Within two stream miles upstream of biocriteria reference locations
- Storm water discharges where:
  - Any of the disturbed area is defined as a wetland (class W), by CSR 20-7.031(1)(F)7
  - The storm water discharges to a sinkhole or other direct conduit to groundwater.

For the purpose of this SWPPP, the term “stream feet” shall mean the distance in feet following the nearest drainage channel from the land disturbance to the valuable resource water.

### **Disturbed Areas**

- Slopes for disturbed areas must be defined for all projects.
- A site map or maps, defining the sloped areas must be included with all SWPPPs.
- Where soil disturbing activities cease in an area for 14 days or more, the contractor shall construct BMPs to establish interim stabilization
  - Interim stabilization consists of well established and maintained BMPs that are reasonable certain to protect waters of the state from sediment pollution.
- BMPs must be suited to the area disturbed, taking into account the drainage area, surfaces of drainage area, and steepness of slope.
- If the slope of the disturbed area is greater than 3:1 (H:V) or if the slope is greater than 3% and greater than 150 feet in length, then the contractor must establish interim stabilization within 7 days of ceasing operations on that part of the site.
- Delays in work caused by inclement weather or equipment malfunctions are not considered ceasing operations for the purpose of this section, as long as work resumes as soon as possible.

### **Installation**

- Installation of all BMPs shall in accordance with the descriptions and details of that BMP as shown in Appendix B.
- Cole County will ensure the BMPs are properly installed at the locations are relative times specified in the SWPPP specific to that site.
- Peripheral or border BMPs to control runoff from disturbed areas shall be installed or marked for preservation before general site clearing is started. Storm water discharges from disturbed areas, which leave the site, shall pass through and appropriate impediment to sediment movement, such as a sedimentation basin, sediment traps, silt fences, etc. prior to leaving the land disturbance site.
- A drainage course change shall be clearly marked on a site map, included in the SWPPP specific to that site.

### **Sedimentation Basins**

- The SWPPP for a specific site will require a sedimentation basin for each drainage area with 10 or more acres disturbed at one time.
- Sedimentation Basins shall be sized to contain a volume of at least 3600 cubic feet per each disturbed acre draining thereto.
- Accumulated sediment shall be removed from the basin as needed to ensure the minimum volume of 3600 cubic feet is maintained.
- Discharges from the basin shall not cause scouring of the banks or bottom of the receiving stream.

- The basin shall be maintained until final stabilization of the disturbed area served by the basin.
- Where the use of a sediment basin of this size is impractical, the SWPPP for a specific site will be allowed to use other similarly effective BMPs to be used to control erosion and sediment delivery. These similarly effective BMPs must:
  - Be selected from BMPs allowed by this SWPPP
  - Provide equivalent protection
- Both temporary and permanent sedimentation basins shall have a stabilized spillway to minimize the potential for erosion of the spillway or basin embankment.

### **Dewatering**

Any dewatering practices that are to be employed on a specific site shall state in that site's SWPPP:

- Description of the method used
- Anticipated volume of water to be discharged
- Anticipated maximum flow rate of discharge (gpm)
- Method for treatment of the water from dewatering operations
  - For no reason shall water from discharging operations be discharged off site without treatment.

### **Roadways**

- All efforts shall be made to prevent deposition of earth and sediment onto roadways through the use of proper BMPs.
- Where sediment is present on roadways, all storm water inlets shall have inlet protection.
- Where storm water will flow off the end of where a roadway terminates, a sediment catching BMP shall be provided
- Roadways and curb inlets shall be cleaned weekly or following a rainfall that generates runoff.
- Stabilized construction entrances shall be used to prevent sediment track out.

### **Amending/Updating the SWPPP**

The SWPPP manager for the site shall amend and update the SWPPP as appropriate during the term of the land disturbance activity. The SWPPP manager shall amend the SWPPP, at a minimum, whenever the:

- Design, operation, or maintenance of BMPs is changed
- Design of the construction project is changed that could significantly affect the quality of the storm water discharges
- SWPPP manager's inspections indicate deficiencies in the SWPPP or any BMP

- MDNR notifies Cole County in writing of deficiencies in the SWPPP
- The SWPPP is determined to be ineffective in significantly minimizing or controlling erosion and sedimentation
- Total Settleable Solids from a storm water outfall exceed 2.5 mg/L/hr (or 0.5 mg/L/hr if discharged to a valuable resource water)
- MDNR determines violations of Water Quality Standards may occur or have occurred

### **Site Inspection Reports**

- Inspections of the site of land disturbance activities shall occur at a minimum of:
  - Once per 7 calendar days
  - Within 48 hours of any rainfall that produces runoff on the site.
- For sites that have not been final stabilized, the following must occur for each inspection:
  - All installed BMPs and other pollution control measures shall be inspected for proper installation, operation and maintenance
  - All storm water outfalls shall be inspected for evidence of erosion or sediment deposition.
  - Receiving streams shall be inspected for 50 feet downstream of the outfall.
  - Any problems shall be noted in an inspection report and corrected within seven calendar days of inspection.
- The SWPPP Manager will be responsible for being aware of rain events that cause runoff on the site. Local weather reports should be viewed, or crews in the vicinity of the site should be consulted if the SWPPP manager does not report to the site regularly.
- If weather conditions make it impossible to correct the problems within seven days, a detailed report of the problem (including pictures), must be filed with the regular inspection reports.
- BMP malfunctions shall be corrected as soon as the weather conditions allow.
- Parts of the site that have been finally stabilized may be inspected once per month. (A once per month inspection schedule may be implemented for a site with interim stabilization if Boone County makes a written request for the schedule and it is approved by the Department)
- A log of each inspection shall be kept.
- The inspection report is to include the following minimum information:
  - Inspector's name
  - Date of inspection
  - Observations relative to the effectiveness of the BMPs
  - Actions taken or necessary to correct the problems
  - Listing of areas where land disturbance operations have permanently or temporarily stopped.
  - Signature of inspector

## **Proper Operation and Maintenance**

Cole County shall at all times maintain all pollution control measures and systems in good order to achieve compliance with the terms of the general permit.

## **Typical Activities**

The following are activities that are typically conducted by Cole County that may require a SWPPP. Some of these activities may need to meet additional requirement of MoDNR and/or other agencies.

Street/Road Construction/Removal  
Land Clearing and Grading  
Tree Clearing  
Storm Sewer Construction/Removal  
Bank Stabilization  
Drainage Channel Construction/Rehab.  
Building Construction/Removal  
Parking Lot Construction/Removal  
Bridge Construction/Removal  
Fill Material Stockpiling (Soil and Rock)

## **SWPPP Management Personnel**

The following Cole County Public Works personnel may be in charge of the management of the SWPPP for projects in Cole County. Other people not listed below may also be involved with the SWPPP of a specific project as employment conditions change. Please see the SWPPP for each particular site for details.

Larry Benz	Greg Block	Spencer Coonce	Andy Myers
Larry Bishop	Joe Braun	Brad Wyss	Kevin Bishop
Eric Landwehr	James Rademan	Kevin Light	
Cliff Lepper	Gene Berhorst	Mark Zimmerman	

## **Appendix A**

### **Temporary and Permanent Structural and Non-Structural BMPs**

The following table lists the BMPs that can be expected to be used on projects requiring a Land Disturbance Permit

Construction Site Best Management Practices (BMPs)

BMP No	Title	Environmental Category						Use	
		Erosion Control	Pollution Prevention	Runoff Management	Sediment Capture	Tracking Control	Temporary	Permanent	
EC-1	Scheduling*	S	P					X	
EC-2	Preservation of Existing Vegetation*	S	P	S	S			X	
EC-3	Dust Control*	P						X	
EC-4	Hydraulic Mulch-bonded Fiber Matrix	P						X	
EC-5	Mulching*	P						X	X
EC-6	Seeding/Mulching*	P						X	X
EC-7	Sodding*	P						X	X
EC-8	Rolled Erosion Control Products	P						X	X
EC-9	Geotextiles and Plastic Covers	P						X	X
EC-10	Outlet/Energy Dissipation Devices	P			S			X	X
EC-11	Temporary Stream Crossings	P						X	
RM-1	Check Dams			P	S			X	X
RM-2	Earth Berms/Drainage Swales			P					X
RM-3	Terracing	S		P	S				X
RM-4	Slope Drains	S		P				X	
RM-5	Soil Roughening*	S		P				X	
RM-6	Fiber Rolls/Wattles	S		P	S			X	
SC-1	Vegetated Filter Strip*	S		S	P				X
SC-2	Silt Fence	S		S	P			X	
SC-3	Straw Bale Dike	S		S	P			X	
SC-4	Compost Filter Socks				P			X	
SC-5	Compost Filter Berms				P			X	
SC-6	Sediment Basins				P			X	
SC-7	Sediment Traps				P			X	
SC-8	Curb and Gutter Inlet Protection				P			X	
SC-9	Drop Inlet Protection				P			X	
TC-1	Construction Entrance/Exit		S			P		X	
TC-2	Washdown Station*		S			P		X	
PP-1	Non-Sediment Pollution Control*		P					X	

P - Primary BMP function; S - Secondary function \*Non-Structural

# BMP Guidelines

## Erosion and Sediment Control Measures

BMP	Definition	Purpose	Where Applicable	Planning	Design Criteria
<p><b>Construction Sequence and Scheduling</b></p>	<p>A specified work schedule that coordinates the timing of land-disturbing activities and the installation of erosion and sedimentation control measures.</p> <p>The objective is to disturb only the immediate work areas.</p>	<p>To reduce on-site erosion and off-site sedimentation by performing land-disturbing activities and installing erosion and sediment control practices in accordance with a planned schedule.</p>	<p>All land-development projects that will disturb more than one contiguous acre.</p>	<p>The general order of construction and planning is:</p> <ul style="list-style-type: none"> <li>• Plan disturbances to coincide with work progress.</li> <li>• Order materials to avoid delays.</li> <li>• Build construction site access.</li> <li>• Implement sediment traps and barriers.</li> <li>• Apply runoff control (diversions).</li> <li>• Implement main runoff conveyance system.</li> <li>• Build stream crossings.</li> <li>• Land clearing and grading.</li> <li>• Surface stabilization.</li> <li>• Building construction.</li> <li>• Landscaping and final stabilization.</li> </ul>	<p>At a minimum, the construction sequence should include:</p> <ul style="list-style-type: none"> <li>• Erosion and sedimentation control practices to be installed.</li> <li>• Principal development activities.</li> <li>• What measures should be in place before other activities begin.</li> <li>• Compatibility with the general construction schedule of the contract.</li> </ul> <p>When changes in construction activities are needed, amend the sequence schedule as necessary to fit the changes.</p>

Adapted from IECAs Tools for Rules: How to Select, Install and Inspect Construction Site BMPs for NPDES Compliance

# BMP Guidelines

## Erosion and Sediment Control Measures

BMP	Definition	Purpose	Where Applicable	Planning	Design Criteria
Protect Existing Vegetation	A construction management tool that retains site vegetation where possible by designating areas on which vegetation will not be disturbed.	<p>Vegetation helps prevent soil erosion in the following ways:</p> <ul style="list-style-type: none"> <li>• Roots hold soil together</li> <li>• Leaves and stems break up rainfall impact</li> <li>• Ground cover slows down runoff and filters sediment out of water</li> <li>• Plants evapotranspire water from soil.</li> </ul>	All land-development projects that will disturb more than one contiguous acre.	<p>Conduct field survey to determine extent of development.</p> <p>Delineate areas of project where existing vegetation will be preserved.</p> <p>Provide a map outlining these areas to grading personnel.</p>	<p>At a minimum, areas of vegetation preservation should be shown on the grading map and instructions presented as to construction procedures to be followed in and around these sensitive areas, including:</p> <ul style="list-style-type: none"> <li>• Placement of safety fence along the perimeter of protected zones</li> <li>• Routine inspection schedule for compliance</li> <li>• Remedial measures for repair and maintenance</li> </ul>

Adapted from IECAs Tools for Rules: How to Select, Install and Inspect Construction Site BMPs for NPDES Compliance

# BMP Guidelines

## Erosion Control Measures

BMP	Definition	Purpose	Where Applicable	Planning	Design Criteria
<p><b>Surface Roughening</b></p>	<p>Preparing the soil topography for the designed construction purpose while taking erosion and sediment control factors into consideration.</p>	<p>To leave the surface soil in a roughened condition to provide temporary soil stabilization and augment future erosion and sediment control practices.</p>	<p>To some extent, on most construction sites that require land disturbing activities, and in particularly where there are critical, erodible slopes.</p>	<p>Designate surface roughening practice based on site conditions and well as equipment availability.</p>	<p>Designing surface roughening techniques into the project is determined by:</p> <ol style="list-style-type: none"> <li>1. Site conditions</li> <li>2. Available equipment (i.e. bulldozers, tractors, etc.)</li> <li>3. Supplemental BMP application (i.e. hydraulic mulch, erosion control blanket, etc.)</li> <li>4. Final landscape design.</li> </ol> <p>Types of surface roughening techniques include:</p> <ul style="list-style-type: none"> <li>• Track walking</li> <li>• Sheepsfoot rolling</li> <li>• Ripping</li> <li>• Imprinting</li> </ul>

Adapted from IECAs Tools for Rules: How to Select, Install and Inspect Construction Site BMPs for NPDES Compliance

# BMP Guidelines

## Erosion Control Measures

BMP	Definition	Purpose	Where Applicable	Planning	Design Criteria
<b>Bench Terracing</b>	Erosion control accomplished by constructing benches or large steps across the land slope.	Reduce the length of slope and thereby the potential for soil erosion.	On steep slopes where erosive factors are very high and gully erosion is likely to take place.	Terrace spacing and slope maintenance need to be considered.	Reduce slope length proportional to the steepness of the slope. Control outlets from terraces so erosion is eliminated.
<b>Slope Interrupter Devices</b>	Tube-like devices composed of a mesh or netting enclosing a biodegradable plant fiber that are installed on the slope contour.	To reduce runoff water velocities and trap sediment particles, thereby ameliorating the impact of slope length and steepness on erosion.	On slopes steeper than 5:1	Follow manufacturer's instructions as to design and specification, particularly in terms of spacing.	Employ slope interrupter devices as a complementary practice to supplement: <ul style="list-style-type: none"> <li>• Surface roughening techniques</li> <li>• Revegetation</li> <li>• Surface mulches, including hydraulic applications and rolled erosion control products</li> <li>• Removal after slope stabilized is optional</li> </ul>

Adapted from IECAs Tools for Rules: How to Select, Install and Inspect Construction Site BMPs for NPDES Compliance

# BMP Guidelines

## Erosion Control Measures

BMP	Definition	Purpose	Where Applicable	Planning	Design Criteria
<b>Temporary Seeding</b>	Planting fast growing vegetation to provide temporary erosion control.	To provide stabilization on bare soil areas that will not be brought to final grade for a period of more than 30 working days.	May be used on cleared unvegetated areas where temporary erosion control is needed.	Selection of appropriate plant species, use of quality seed, proper bed preparation, and seed application method are important.	The area to be seeded should be uniform an loosened to a minimum depth of 3 inches. The area should be cleared of stones, roots and other debris.
<b>Turf Reinforcement Materials (TRM)</b>	Three-dimensional fabrics of synthetic materials placed in areas of concentrated flow to provide plant reinforcement.	To provide increased shear strength to allow plant material usage in drainage channels as a functional substitute for hard armoring.	Drainage channels, swales, slope drains and as separators between rip rap and underlying soil.	Follow manufacturer's recommendation as to design, specification and suitability of material for site.	Installation of TRMs is critical to their performance in the field. Follow manufacturer's recommendation as to design, specification and installation of the material in conjunction with its vegetative component.
<b>Permanent Seeding/Planting of Grasses</b>	Control of runoff and erosion with permanent vegetation.	To economically control erosion and sedimentation.	Used on graded or cleared areas where soil is unstable because of texture, structure, high water table, or slope.	Selection of appropriate plant species, use of quality seed, and proper bed preparation are important.	Planting should occur within 14 days of final grading.

Adapted from IECAs Tools for Rules: How to Select, Install and Inspect Construction Site BMPs for NPDES Compliance

# BMP Guidelines

## Erosion Control Measures

BMP	Definition	Purpose	Where Applicable	Planning	Design Criteria
<b>Topsoiling</b>	Stropping off, storing, and spreading the upper layers of soil over disturbed areas.	To provide a suitable medium for vegetation establishment and growth.	Wherever it is economically practical, this technique should be considered. Recommended for use in areas where subsoil is infertile and other methods will not produce or maintain a desirable stand of vegetation.	Recommended for placement on soils that do not have a deep rooting zone to support plants, and that may contain material toxic to plant growth, and where exposed subsoil is not suitable to produce adequate vegetation.	Should be applied on slopes 2:1 or flatter.  Sample topsoil or duff material and apply lime and fertilizer as appropriate.
<b>Permanent Ground Cover Plants</b>	Control of runoff and erosion with trees, vines and shrubs by stabilizing soils in areas where vegetation other than grasses or legumes is preferred.	To economically control erosion and sedimentation.	Used on steep banks, graded cleared areas, and shady areas where turf maintenance is difficult. Also, can be used between terraces.	Selection of species should match soil characteristics. Quality stock should be selected and kept moist form time of receipt and planted as soon as possible.	Usually more effective when planted in clumps or blocks. Competitive vegetation should be pulled out of the areas where the plants are to be planted.

Adapted from IECAs Tools for Rules: How to Select, Install and Inspect Construction Site BMPs for NPDES Compliance

# BMP Guidelines

## Erosion Control Measures

BMP	Definition	Purpose	Where Applicable	Planning	Design Criteria
Mulching	Use of a protective layer of straw, hay, wood chips, wood fibers, gravel, or synthetic materials on the soil surface to reduce rainfall impact and dislodgement of soil particles.	To protect the soil surface from the erosive forces of raindrop impact and overland or sheet flows.  A secondary benefit of surface mulch is to retain soil moisture and moderate soil temperatures, aiding plant establishment.	As a temporary, non-vegetative surface erosion control treatment and/or in conjunction with a temporary or permanent re-vegetation technique, such as aerial or hydraulic seeding.	Application of temporary or permanent mulch materials should be planned to coincide with schedule of disturbance and final landscape design.	Organic mulches are most effective when uniformly spread and secured to the soil structure. <ul style="list-style-type: none"> <li>• Cost</li> <li>• Longevity</li> <li>• Ease of installation</li> <li>• Erosion control effectiveness</li> <li>• Runoff vs. infiltration characteristics</li> <li>• Compatibility with revegetation strategy</li> <li>• Water quality impact</li> </ul> Types of surface mulch materials/techniques include: <ul style="list-style-type: none"> <li>• Straw or hay fibers</li> <li>• Paper or wood fibers</li> <li>• Gravel</li> <li>• Wood chips</li> <li>• Compost</li> <li>• Hydraulic matrices of cellulose fiber and tackifying agent</li> <li>• Bonded fiber matrices</li> <li>• Rolled erosion control products</li> </ul>

Adapted from IECAs Tools for Rules: How to Select, Install and Inspect Construction Site BMPs for NPDES Compliance

# BMP Guidelines

## Erosion Control Measures

BMP	Definition	Purpose	Where Applicable	Planning	Design Criteria
<b>Sodding</b>	Use of grass sod to permanently stabilize an area.	To rapidly prevent erosion and sedimentation.	May be used in areas requiring immediate and permanent vegetative cover, particularly in landscaping applications.	More costly than seeding, but can be established during times of the year when grass seed may fail. Irrigation may be necessary.	On slopes, sod should be applied with the long dimension perpendicular to the slope and pegged or stapled sufficiently to prevent movement.
<b>Riprap or Aggregate</b>	Permanent layers of loose angular stones or aggregate with a filter fabric or granular underlining placed over an erodible soil surface.	To protect the soil surface from the erosive flow of water, slow water flow velocity, and stabilize slopes.	Used when soil may erode under design flow conditions and cannot be protected by vegetative cover or other means. Riprap can be used at: <ul style="list-style-type: none"> <li>• Storm drain outlets,</li> <li>• Channel banks and bottoms,</li> <li>• Roadside ditches,</li> <li>• Drop structures,</li> <li>• Toe of slopes,</li> <li>• Channel transitions</li> </ul>	Graded riprap contains a mixture of stone sizes while uniform riprap is made up of stones of similar sizes. <p>The size of stone used is directly related to the design flow velocity of the channel.</p> <p>Typically should be used for velocities in excess of 15 ft/sec.</p>	The minimum riprap thickness is 2 times the maximum stone diameter but not less than 6 inches. The specific gravity of the individual stones should be at least 2.5. <p>Maxim bank slope for application should not be steeper than 1.5:1.</p>

Adapted from IECAs Tools for Rules: How to Select, Install and Inspect Construction Site BMPs for NPDES Compliance

# BMP Guidelines

## Erosion Control Measures

BMP	Definition	Purpose	Where Applicable	Planning	Design Criteria
<b>Outlet Protection</b>	Structurally lined aprons or other acceptable energy dissipation devices placed at the outlets of pipes or paved channel sections.	To protect the soil surface from the erosive flow of water, slow the water flow velocity, and stabilize slopes or channels.	Used where the flow velocity at the design capacity will exceed the velocity of the receiving channel or area.	Geotextile fabrics in conjunction with vegetation create a natural outlet protection. Riprap aprons are relatively low cost and easy to install. Riprap stilling basins or plunge pools are used where overfalls exit the ends of pipes where high flows would require excessive apron lengths.	Capacity: 10-year peak runoff or design discharge of conveyance, whichever is greater.  Geotextile fabrics should be designed to handle peak flow rates and tractive forces.  The depth of a riprap apron should be 2 times the max. stone diameter but not less than 6 inches.
<b>Dust Control</b>	Actions or methods which reduce the erosive effects of wind on dry soils.	To prevent soil particles in the form of dust from becoming airborne.	Used where open dry areas of soil, particularly in dryer climates or during the dry season, are exposed to the erosive factors of the wind.	The direction of the prevailing winds and careful planning of clearing activities are important.	Minimize the period of soil exposure through use of temporary ground cover and other stabilization practices. Some possible dust control measures are: <ul style="list-style-type: none"> <li>• Vegetative cover,</li> <li>• Mulch or Stone</li> <li>• Spray-on adhesive</li> <li>• Calcium chloride</li> <li>• Sprinkling</li> </ul>

Adapted from IECAs Tools for Rules: How to Select, Install and Inspect Construction Site BMPs for NPDES Compliance

# BMP Guidelines

## Sediment Control Measures

BMP	Definition	Purpose	Where Applicable	Planning	Design Criteria
<b>Sediment Basins</b>	A suitably located temporary or permanent earthen embankment, barrier, dam, or excavated basin designed to capture sediment.	To retain sediment on the construction site and prevent sedimentation to off-site waterbodies, properties, etc.	Used where erosion control measures are not adequate to prevent off-site sedimentation on sites with disturbed area of 5 acres or more.	Hazard class must be considered so failure does not jeopardize property or lives. The location of the basin must be able to collect all of the site runoff.	Drainage area is between 5 and 150 acres. The flow length through the basin length to width ratio should be 2:1 or greater.
<b>Temporary Sediment Trap</b>	A small temporary ponding basin formed by constructing an embankment across a drainage swale, by excavating a pond or by rock fill.	To detain sediment-laden runoff from small, disturbed areas long enough to allow the majority of the sediment to settle out.	Used at the outlets of drains, diversions, channels, and other runoff conveyances. May be installed during early site development.	Access to trap must be maintained to periodically removed sediment for proper disposal. Structure life is limited to 18 months.	Used for drainage areas of 5 acres or less. Minimum storage area is fixed to meet 80% removal efficiency. Side slopes of the excavated trap should be 2:1 or flatter. Maximum height is 5 ft.
<b>Silt Fence</b>	Sediment barrier consisting of synthetic filter fabric stretched across posts with the bottom of the fabric being entrenched. In most cases the fabric should be reinforced with the support of a wire fence.	To catch and hold small amounts of sediment from disturbed areas by reducing the velocity of sheet flow to allow sediment deposition.	Used below small, disturbed areas less than 1/4 acre per 100 ft. of fence, and where runoff can be stored behind the fence without damaging the fence or the area behind it.	Should be located where shallow pools can be formed. Sediment deposition should be periodically removed and properly disposed of. Breaks in the fence should be used to minimize drainage areas.	Fence should be stable for the 10-yr storm. The slope should be no longer than 100 ft. and have a gradient of 2:1 or flatter. The minimum fabric height is 18 in. Maximum post spacing is 6 ft. Minimum post burial depth is 12 in.

Adapted from IECAs Tools for Rules: How to Select, Install and Inspect Construction Site BMPs for NPDES Compliance

# BMP Guidelines

## Sediment Control Measures

BMP	Definition	Purpose	Where Applicable	Planning	Design Criteria
<b>Rock Ditch Checks</b>	Small temporary dams constructed across a swale or drainage ditch to reduce the velocity of concentrated storm flows.	To reduce erosion of the channel by restricting the velocity of flow in the channel. Not to be installed in live channels or waters of the commonwealth.	Used as a temporary or emergency measure to limit erosion by reducing flow in a small open channel.	Ditch checks should not be used in live streams but are intended for temporary ditches and swales. Checks in grass channels may kill the vegetation. Ditch checks shall be promptly removed when their useful life has been completed.	Drainage area should not exceed 10 acres. The maximum height is 2 ft. at the center. The center should be at least 6 in. lower than the outer edges. The maximum spacing between checks should be such that the toe of the upstream check is at the same elevation as the top of the downstream check. The maximum size of stone used should be no greater than 8 in. in diameter.
<b>Stabilized Construction Entrance</b>	A gravel driveway or pad located at a point where vehicle enter and exit a construction site.	To reduce the amount of mud and soil transported onto public roads by traffic leaving the construction site.	Used wherever traffic leaves a construction site and enters a public right-of-way, street, alley, sidewalk, parking lot or other paved area.	Construction plans should limit all traffic to properly constructed entrances and exits.	Stone should be KTC #3 or larger. Pad thickness has a 6 in. minimum with a required geotextile fabric underlying the stone. The minimum width of the entrance shall be 24 ft. while the minimum length shall be 100 ft.

Adapted from IECAs Tools for Rules: How to Select, Install and Inspect Construction Site BMPs for NPDES Compliance

# BMP Guidelines

## Sediment Control Measures

BMP	Definition	Purpose	Where Applicable	Planning	Design Criteria
<b>Storm Drain Inlet Filters</b>	A sediment filter or an excavated impounding area surrounding a storm drain inlet.	To retain sediment on the construction site by slowing and filtering runoff before it enters the storm drainage system.	Used where storm drain inlets are to be made operational before permanent stabilization of the disturbed area occurs.	<p>Must not be used near the edge of fill material and must not divert water over cut or fill slopes.</p> <ul style="list-style-type: none"> <li>• Filter Fabric Inlet Protection</li> <li>• Stone Bag Inlet Protection</li> <li>• Block and Gravel Drop Inlet</li> <li>• Protection</li> <li>• Gravel and Wire Mesh Inlet</li> <li>• Sediment Filter</li> </ul>	The drainage area must be no greater than 1 acre with a slope less than 5%.
<b>Vegetated Filter Strips</b>	Zones of vegetation through which sediment and pollutant-laden runoff are directed before being discharged to a concentrated flow channel.	Filter strips are used to remove sediment from overland sheet flow but are not effective in removing sediment from concentrated flows.	Used where runoff from land undergoing development needs to be filtered to reduce sediment damage to adjacent properties, streams or sinkholes.	Effectiveness can vary depending on vegetation, height, type and density, season of the year, soil eroded particle size characteristics, size of disturbed area, and site topography.	<p>The General Design Criteria are:</p> <p>Min. Width = 15 ft.            Max. Ground Slope = 1%            Max. Ground Slope = 10%.</p>

Adapted from IECAs Tools for Rules: How to Select, Install and Inspect Construction Site BMPs for NPDES Compliance

# BMP Guidelines

## Temporary Flow Control and Conveyance Measures

BMP	Definition	Purpose	Where Applicable	Planning	Design Criteria
<b>Temporary Pipe Slope Drains</b>	Flexible tubing or conduit extending temporarily from the top to the bottom of a cut or fill slope.	To convey concentrated runoff down the face of a cut or fill slope to a protected stable area without causing erosion.	Used on sites before permanent stormwater drainage structures are installed and where stormwater runoff above a cut or fill slope will cause severe erosion if allowed to flow over the slope.	Must be sized, installed, and maintained properly because failure results in slope gully erosion. The entrance must be securely entrenched with watertight connections, with securely staked conduit.	Should handle peak runoff from the 10-yr storm. The maximum drainage area per pipe is 10 acres. The entrance should be constructed of a standard flared end section of pipe or equivalent. Reinforced hold-down garments should be spaced at 10 ft. or less intervals.
<b>Runoff Control Measures</b>	A temporary ridge, excavated channel, or combination ridge and channel constructed across sloping land at a pre-determined grade.	To divert clean water around work sites to stable outlets and to divert sediment-laden water to sediment control structures such as sediment traps and basins.	<ul style="list-style-type: none"> <li>Above slopes to prevent clean runoff from flowing over unprotected soil.</li> <li>Across unprotected slopes to reduce flow lengths.</li> <li>Below slopes to divert runoff to a stable outlet, and</li> <li>Within and below disturbed areas to direct sediment-laden water to control structures.</li> </ul>	Design as a stable channel with a mild bed slope. Use of either uniform or a gradually increasing grade is preferred over sudden decreases or increases in grade. A permanent vegetative covering is required where the channel grade is between 0.2% and 3%.	Design drainage area is 5 acres or less based on the peak runoff from the 10-yr. storm. A channel lining is required if the average velocity is greater than 2 ft/sec. Channel side slopes are 2:1 or flatter. The berm must have side slopes of 2:1 or flatter, with a minimum top width of 2 ft. and a designed freeboard of at least 4 in.

Adapted from IECAs Tools for Rules: How to Select, Install and Inspect Construction Site BMPs for NPDES Compliance

# BMP Guidelines

## Permanent Flow Control and Conveyance Measures

BMP	Definition	Purpose	Where Applicable	Planning	Design Criteria
<b>Subsurface Drains</b>	A perforated pipe or conduit placed beneath the surface of the ground at a designated depth and grade.	Used to drain saturated soils by lowering the water table.	Used in areas free from tree roots where the soil layer depth is deep enough to allow proper installation.	Not recommended in areas where the drain will pass under heavy vehicle crossings.	Should be designed for required capacity. The minimum diameter should be 6 in. The line should be graded to achieve at least a velocity of 2.4 ft/sec to prevent silting.
<b>Level Spreader</b>	Structure that converts sediment-free channel flow and uniformly releases it over a stabilized area.	Provides stable outlets for diversion channels, basins, dikes and other structures.	Used where sediment free storm runoff can be released as sheet flow over a stable area.	Install in areas where the level lip can be constructed without using fill material. The discharge area should have a maximum 10% slope and be well-vegetated and stable for design flow conditions. There should be no traffic across a level spreader.	Capacity determined by peak flow from the 10-yr. storm. The maximum desirable flow into the spreader should not exceed 30 cfs. Spreader length, width and depth are designed based on flow. There should be a 20 ft. long transition section between the channel entrance and the design width of the spreader. The grade of the spreader invert and lip must be 0.

Adapted from IECAs Tools for Rules: How to Select, Install and Inspect Construction Site BMPs for NPDES Compliance

# **Appendix B**

## **BMP Descriptions and Details**

(Taken from Chapter 8 of the Boone County Storm Water Manual)



## CHAPTER 8 EROSION AND SEDIMENT CONTROL

### 8.1 Introduction

These guidelines are intended to provide the designer, contractor and builder with design criteria and minimum standards for the installation of erosion and sediment controls to comply with the Erosion and Sediment Control Regulations. The regulations were enacted to protect the health, safety, and property of the citizens and to help protect area water resources from pollution due to erosion and transportation of sediment. The regulations are applicable to all land development and land disturbance activity within the regulated MS4 area where the area of disturbance is more than one acre. The regulations require that no person cause or allow sediment to be deposited in any public street, public land, or on any property not under their control as a result of land disturbance from construction activities.

You can comply with the regulations by meeting the following objectives:

- a. Minimize the area disturbed by construction and development;
- b. Provide for containment of sediment until areas are stabilized;
- c. Stabilize disturbed areas as soon as practical after project completion; and
- d. Provide permanent erosion, drainage, and detention controls.

### 8.2 General Design Guidelines

Erosion is a natural process where soil and rock are loosened and removed. Natural erosion normally occurs at a very slow pace, but when land is disturbed by vegetation removal, grading and other construction activities, the erosion rate often increases dramatically. When erosion occurs on a construction site the sediment is available for transport by either wind or stormwater runoff. The discharge of sediment and other construction site pollutants can negatively impact downstream water quality.

The purposes of erosion and sediment controls are to minimize the amount of erosion that occurs as a result of construction activities and to prevent the sediment from leaving the property. Effective erosion and sediment control requires that the soil surface be protected from the erosive forces of wind, rain, and runoff and that the eroded soil be captured and retained onsite.

When designing sediment and erosion controls, it is necessary to determine whether there is **sheet flow** or **concentrated flow** of stormwater on the property. Sheet flow occurs on gently sloping land without defined drainage ways. The stormwater tends to disperse evenly across the property, although the drainage may be in one direction due to the overall slope. Concentrated flow occurs where there are defined drainage ways that may range from gentle swales to clearly defined waterways. It is possible to have a combination of sheet flow and concentrated flow on the same property.



### **1. Erosion Protection**

Proper planning will help identify potential erosion problems, particularly highly susceptible areas, such as areas of concentrated flow. Removing the vegetative cover and altering the soil structure by clearing, grading and compacting the surface increases an area's susceptibility to erosion. Scheduling can be a very effective means of reducing erosion by minimizing both the exposed area and the duration of exposure. Apply stabilizing measures as soon as possible after the land is disturbed. Plan and implement temporary or permanent vegetation, mulches, or other protective practices to correspond with construction activities. Protect channels from erosion forces by using protective linings and the appropriate channel design. Consider possible future repairs and maintenance of these practices in the design. In scheduling, take into account the season and the weather forecast.

Clearing existing vegetation reduces the surface roughness and infiltration rate and increases runoff velocities and volumes. This is particularly a concern in areas of concentrated flow. Use measures that break the slopes to reduce the problems associated with concentrated flow volumes and runoff velocities. Practical ways to reduce velocities include conveying stormwater runoff away from steep slopes to stabilized outlets, preserving natural vegetation where possible, and mulching and vegetating exposed areas immediately after construction.

### **2. Sediment Containment**

Even with careful planning some erosion is unavoidable, and the resulting sediment must be trapped on the site. In areas where runoff occurs primarily as sheet flow, containment of sediment is relatively simple. In these areas, temporary containment devices may be sufficient. Where concentrations of flow occur, containment of sediment becomes more difficult as the rate and volume of flow increase. In these areas, more extensive or permanent control devices need to be provided. Areas of steep topography and cut or fill slopes need to be given special consideration. Due to the environmental sensitivity of streams, rivers, losing streams, sinkholes, and other Karst topographic features, special consideration also needs to be given to these areas. Plan the location where sediment deposition will occur and maintain access for periodic removal of accumulated sediment. Protect low points below disturbed areas by building barriers to reduce sediment loss. Sediment traps and basins should be constructed before other land-disturbing activities occur.

### **3. Temporary versus Permanent Controls**

Temporary controls, such as straw bale dikes, silt fences, erosion control blankets, etc., are provided for the purpose of controlling erosion and containing sediment until construction is complete. Temporary controls are not needed after the area is stabilized.

Permanent controls consist of riprap, detention basins, etc., which will remain in place through the life of the development. It is possible for the same facility to serve both a temporary and permanent purpose.



#### 4. Maintenance

Regular inspection and maintenance of Best Management Practices (BMPs) are vital to the performance of erosion and sedimentation control measures. If not properly maintained, some practices may cause more damage than they prevent. Always evaluate the consequences of a measure failing when considering which control measure to use, since failure of a practice may be hazardous or damaging to both people and property. For example, a failure of a large sediment basin can have disastrous results, and low points in dikes can cause major gullies to form on a fill slope. It is essential to inspect all practices to determine that they are working properly and to ensure that problems are corrected as soon as they develop.

### 8.3 BMP Descriptions and Design Guidance

The following principles are effective when they are integrated into a system of control practices and management techniques to control erosion and prevent sedimentation offsite. As a matter of practicality, proprietary erosion and sediment control products are not specifically identified herein. However, the County encourages the use of these products when designed, specified and installed in accordance with manufacturer's recommendations. Sufficient details related to these products should be supplied to facilitate the review of the plans to ensure the suitability of the practice. The following is not meant to provide an exhaustive list of all acceptable erosion and sediment control practices accepted by the county, only as a general guidance document.

There may be instances where certain erosion control designs are beyond the scope of general civil engineering knowledge. Specifically, natural stream stabilization and/or restoration should only be done with specific expertise and experience with these systems. This manual is not intended to convey such a level of knowledge and therefore will not address this level of complexity.

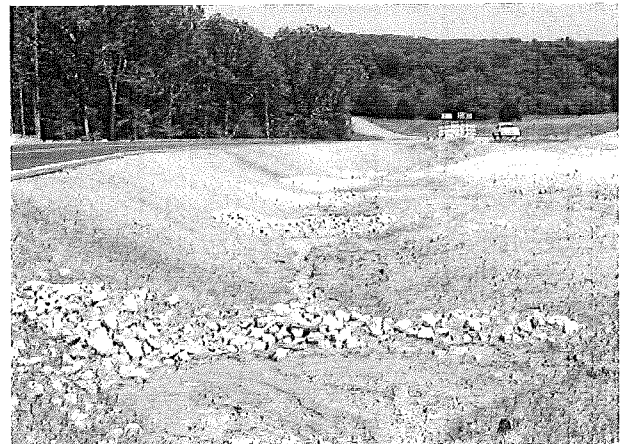
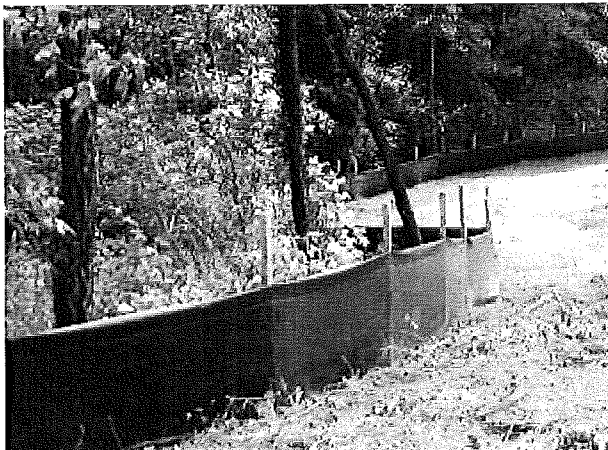

Figure 1. Silt Fences are placed at the perimeter of the job site to capture and prevent sediment from leaving the site.

Figure 2. Rock Check dams can reduce water velocities in areas of channelized flow.



## **EC-1 SCHEDULING**

This BMP involves developing a schedule that includes sequencing of construction activities with the implementation of construction site BMPs such as temporary soil stabilization (erosion control) and temporary sediment control measures for every project. The purpose is to reduce the amount and duration of soil exposed to erosion by wind, rain, runoff and vehicle tracking, and to perform the construction activities and control practices in accordance with the planned schedule.

### APPROPRIATE APPLICATIONS:

Construction sequencing shall be scheduled to minimize land disturbance for all projects at all times.

### CONDITIONS FOR EFFECTIVE USE:

All land disturbing activities.

### WHEN BMP IS TO BE INSTALLED:

Scheduling should take place during the planning stages and be modified throughout the duration of the project.

### STANDARDS AND SPECIFICATIONS:

Developing a schedule and planning the project are the very first steps in an effective storm water program. The construction schedule shall be incorporated into the SWPPP. Develop the sequencing and timetable for the start and completion of each item such as site clearing and grubbing, grading, excavation, paving, pouring foundations, installing utilities, etc., to minimize the active construction area during the rainy season. Schedule major grading operations for the non-rainy season when practical. Incorporate staged seeding and re-vegetation of graded slopes as work progresses. Consider the appropriate planting time for specified vegetation when establishing permanent vegetation.

### OPERATION AND MAINTENANCE PROCEDURES:

Verify that work is progressing in accordance with the schedule. If progress deviates, take corrective actions. Amend the schedule when changes are warranted.

## **EC-2 PRESERVATION OF EXISTING VEGETATION**

Preservation of existing vegetation is the identification and protection of desirable vegetation that provides erosion and sediment control benefits and includes establishing setbacks to protect stream banks according to the County stream buffer regulations.

### APPROPRIATE APPLICATIONS:

Preserve existing vegetation at areas on a site where no construction activity is planned or will occur at a later date.



CONDITIONS FOR EFFECTIVE USE:

Protection of existing vegetation requires planning, and may limit the area available for construction activities.

WHEN BMP IS TO BE INSTALLED:

Existing vegetation to be preserved shall be identified on the plans. Measures to protect said vegetation (such as construction fencing and signage) should be installed prior to the commencement of clearing and grubbing operations or other soil-disturbing activities.

STANDARDS AND SPECIFICATIONS:

Minimize the disturbed areas by locating temporary roadways to avoid stands of trees and shrubs and to follow existing contours to reduce cutting and filling. Mark areas to be preserved with temporary fencing at least 3.2 ft. tall. The fence post spacing and depth shall be adequate to completely support the fence in an upright position. Construction materials, equipment storage, and parking areas shall be located where they will not cause root compaction. Keep equipment away from trees to prevent trunk and root damage. Employees and subcontractors shall be instructed to honor protective devices. No heavy equipment, vehicular traffic, or storage piles of any construction materials shall be permitted within the drip line of any tree to be retained. Trenching shall be as far away from tree trunks as possible, usually outside of the tree drip line or canopy. The ends of damaged or cut roots shall be cut off smoothly.

OPERATION AND MAINTENANCE PROCEDURES:

During the construction phase(s), limits of disturbance shall remain clearly marked at all times. If damage to protected trees occurs, the injured tree shall be attended to by an arborist.

SITE CONDITIONS FOR REMOVAL:

Temporary fencing shall be removed after final stabilization of the site has occurred.

**EC-3 DUST (WIND EROSION) CONTROL**

Wind erosion control consists of applying water and/or other dust palliatives as necessary to prevent or alleviate erosion by the forces of wind. Alternatives to applying water or other dust palliatives include mulch or vegetative cover, wind barriers, and minimization of soil disturbance.

APPROPRIATE APPLICATIONS:

This practice is implemented on all exposed soils subject to wind erosion.

CONDITIONS FOR EFFECTIVE USE:

Effectiveness depends on soil, temperature, slope, aspect, humidity and wind velocity.

WHEN BMP IS TO BE INSTALLED:



Dust control should be performed routinely, especially in advance of and during periods of dry weather.

#### STANDARDS AND SPECIFICATIONS:

Water shall be applied by means of pressure-type distributors or pipelines equipped with a spray system or hoses and nozzles that will ensure even distribution. Phase work to the extent practical to minimize concurrent areas of soil disturbance. For areas not subjected to traffic, vegetation provides the most practical method of dust control and should be established as early as possible. Wind barriers such as solid board fences, snow fences, burlap fences, crate walls, and similar materials can be used to control air currents and blowing soil. Barriers placed at right angles to prevailing wind currents at intervals of about 10 times their height are effective in controlling soil blowing. Paved areas that have soil on them from construction sites should be cleaned regularly. Mulching offers a fast and effective means of controlling dust when properly applied. Binders and tackifiers may need to be used on organic mulches. NOTE: If calcium chloride or spray-on adhesives are used for dust control, a permit may be required from MoDNR.

#### OPERATION AND MAINTENANCE PROCEDURES:

Check areas that have been protected to ensure coverage.

#### SITE CONDITIONS FOR REMOVAL:

Dust control should be implemented when soils are exposed until cover is established.

### **EC-4 HYDRAULIC MULCH-BONDED FIBER MATRIX**

Hydraulic mulch consists of applying a mixture of shredded wood fiber or a hydraulic bonded fiber matrix (BFM) and a stabilizing emulsion or tackifier with hydroseeding equipment, which temporarily protects exposed soil from erosion by raindrop impact or wind. BFMs adhere directly to the soil, eliminating gaps between the product and the soil. A water-insensitive crust does not form; therefore plant growth is not inhibited. Mulch and BFMs will biodegrade completely into material beneficial to plant growth. Seed may be applied simultaneously with mulching.

#### APPROPRIATE APPLICATIONS:

Hydraulic mulch and BFMs are applied to disturbed areas requiring temporary protection until permanent vegetation is established or disturbed areas that must be re-disturbed following an extended period of inactivity.

#### CONDITIONS FOR EFFECTIVE USE:

Type of Flow: Sheet flow only.

Wood fiber hydraulic mulches and BFMs are generally short-lived (only last part of a growing season) and need 24 hours to dry before rainfall occurs to be effective.



WHEN BMP IS TO BE INSTALLED:

Hydraulic mulch or bonded fiber matrix should be applied immediately after completion of a phase of grading.

STANDARDS AND SPECIFICATIONS:

Follow manufacturer's recommendations to maximize usefulness. Avoid mulch over-spray onto the traveled way, sidewalks, and lined drainage channels. Materials for wood fiber-based hydraulic mulches and bonded fiber matrices shall meet environmental quality standards and not be a detriment to stormwater discharges from the site.

OPERATION AND MAINTENANCE PROCEDURES:

Inspect at least every week and after every storm until vegetation is fully established. Repair eroded areas and reapply product and vegetation.

SITE CONDITIONS FOR REMOVAL:

Typically these materials are left in place to degrade naturally.

**EC-5 MULCHING**

A layer of organic material designed to protect exposed soil or freshly seeded areas from erosion by eliminating direct impact of precipitation and slowing overland flows. Mulch materials may include, but are not limited to, grass, hay, straw, wood chips, wood fibers, and shredded bark.

APPROPRIATE APPLICATIONS:

Typically used for soil stabilization as a temporary surface cover on disturbed areas until soils can be prepared for revegetation and permanent vegetation is established. Mulch can also be installed in land-scape areas for permanent use.

CONDITIONS FOR EFFECTIVE USE:

Type of Flow: Sheet flow only

The use of appropriate mulch will help ensure the vegetation is established under normal conditions and is essential to seeding success under harsh site conditions. General mulch recommendations to protect from raindrop splash and sheet flow include: straw applied at 2-2.5 tons/acre, wood fiber or wood cellulose applied at 0.5-1 ton/acre, wood chips applied at 5-6 tons/acre, and bark applied at 35 yd<sup>3</sup>/acre. Where slopes are 25 percent (4:1) or greater, hydromulch, bonded fiber matrix, or erosion control blankets are required.

WHEN BMP IS TO BE INSTALLED:

Mulch should be applied immediately after grading landscaped areas or seeding other areas.

STANDARDS AND SPECIFICATIONS:



Install upstream BMPs to protect area to be mulched. Rough grade area and remove all debris larger than 1 inch if area is to be vegetated and mowed in the future, larger than 2 inches if area is to be permanently mulched. If area is to be seeded, follow requirements of Seeding BMP. Spread mulch evenly.

#### OPERATION AND MAINTENANCE PROCEDURES:

Inspect at least every week and after every storm until adequate vegetation is established; annually for permanent mulch. Protect from vehicular and foot traffic. Repair damaged, degraded or eroded areas-reseed as needed and replace mulch.

#### **EC-6 SEEDING/MULCHING**

Establishment of vegetation by spreading grass seed designed to protect exposed soil from erosion by eliminating direct impact of precipitation and slowing overland flow rates. Once established, the vegetative cover will also filter pollutants from the runoff.

#### APPROPRIATE APPLICATIONS:

Exposed soil after a phase of rough or finish grading has been completed, or areas where no activity will occur for 14 days.

#### CONDITIONS FOR EFFECTIVE USE:

Type of Flow: Sheet flow and concentrated flow (additional stabilization is necessary).

Minimum Rates: Permanent seeding should consist of 90% tall fescue and 10% annual ryegrass. Seed mixture should be applied at 400 pounds/acre. Temporary seeding shall consist of any combination of tall fescue, annual ryegrass, millet, wheat or oats. Seed mixture should be applied at 200 pounds/acre. Dormant season seeding, seed mix should consist of 80% tall fescue, 10% annual ryegrass and 10% spring oats. Seed mixture is to be applied at 600 pounds/acre.

Acceptable Dates: Permanent seeding may be done March 1 to June 1 and August 15 to November 1. Temporary seeding can occur during any season, however winter is the least tolerant. Dormant season seeding includes December 15 to February 29.

#### WHEN BMP IS TO BE INSTALLED:

Seed and mulch should be applied immediately after rough or finished grading is completed.

#### STANDARDS AND SPECIFICATIONS:

Install upstream BMPs to prevent erosion and protect the area to be seeded. Complete grading and remove all debris larger than 1 inch. Loosen compacted soils to a depth of 4 inches. Groove or furrow on the contour if necessary. Spread loose topsoil at a depth of 4 inches.

Soil amendments should be applied per soil tests. When these are not available, lime shall be applied at the rate of 1500 pounds effective neutralizing material per acre. Soils with a pH of six



or higher need not be limed. When soil tests are not available, a 13-13-13 grade fertilizer shall be applied at a rate of 500 pounds/acre for permanent seeding and a 10-10-10 grade fertilizer shall be applied at the rate of 200 pounds/acre. Mix soil amendments (lime, fertilizer, etc.) into the top 4 inches of soil.

Plant seed  $\frac{1}{4}$  to  $\frac{1}{2}$  inches deep using a cyclone seeder, drill, cultipacker seeder, or hydro-seeder. Roll lightly to firm surface. Cover seeded area with mulch. Install additional stabilization (erosion control blankets, netting, bonded fiber matrix, etc.) on slopes steeper than 3:1 and in areas of concentrated flow. Water seeded area immediately. Provide enough water to soak 4 inches into the soil without causing runoff.

#### OPERATION AND MAINTENANCE PROCEDURES:

Inspect at least weekly and after every storm. Protect seeded areas from vehicular and foot traffic. Reseed and mulch areas that have not sprouted within 21 days of planting. Repair damaged or eroded areas and reseed/mulch and stabilize as needed. Do not mow until 4 inches of growth occurs. During the first 4 months, mow no more than  $\frac{1}{3}$  the grass height.

#### **EC-7 SODDING**

Sod consists of a  $\frac{3}{4}$  inch to 1 inch mat of vigorous turf, free from disease, insects and weeds. Sod prevents raindrops from disrupting the soil structure and causing erosion. Sod slows water runoff and acts as a filter when sediment laden runoff crosses over the sodded area.

#### APPROPRIATE APPLICATIONS:

Typically installed in areas requiring immediate erosion protection, such as swales or detention ponds and as filter strips, around inlets, and adjacent to curbs. Also installed in areas requiring immediate aesthetic appearance or function such as entrances to new subdivisions and off site construction areas.

#### CONDITIONS FOR EFFECTIVE USE:

Type of Flow: Sheet flow and low concentrated flows with velocities less than 5 fps.

#### WHEN BMP IS TO BE INSTALLED:

Sod should be installed immediately after finish grading, installation of area inlets, and installation of underground services and foundations of new homes.

#### STANDARDS AND SPECIFICATIONS:

Rough grade area and remove all debris larger than  $\frac{1}{2}$  inch in diameter and concentrated areas of smaller debris. Soil preparation of area to be sodded shall be determined by tests to determine lime and fertilizer requirements. Scarify soil and level to provide an even grade. Soil should not be excessively wet or dry. Lay first row of sod perpendicular to the slope or direction of flow. Butt subsequent rows tight against previous rows with strips staggered in brick-like pattern. Fill minor gaps with good soil and roll entire surface to ensure contact. Stake, staple and/or net



corners and centers of sod strips as required, especially areas of concentrated flow. Water should be applied immediately after installation of sod. Provide enough to soak 4 inches into the soil without causing runoff.

#### OPERATION AND MAINTENANCE PROCEDURES:

Water sod daily for 3 weeks, enough to soak 4 inches into the soil without causing runoff. Reposition areas of sod that have moved along the slope. Remove sediment accumulations, replace sod if necessary. Repair any eroded areas, replace sod, and stabilize as needed. Do not mow until 3 inches of new growth occurs. During the first 4 months, mow no more than 1/3 the grass height.

### **EC-8 ROLLED EROSION CONTROL PRODUCTS**

Rolled erosion control products include erosion control blankets and turf reinforcement mats. Erosion control blankets are pre-formed protective blanket of plastic fibers, wood fibers, straw or other plant residue designed to protect soil from the impact of precipitation and overland flow, and retain moisture to facilitate establishment of vegetation. Turf reinforcement mats include netting designed to anchor the root system of the vegetation growing through it.

#### APPROPRIATE APPLICATIONS:

These products may be installed on seeded areas for temporary or permanent use.

#### CONDITIONS FOR EFFECTIVE USE:

Several factors, such as soil conditions, steepness and length of slope, depth of flow, runoff velocities, and time required to establish desired vegetation, influence the choice of product. Manufacturer's recommendations should be followed. Products are available for a variety of uses: Netting-synthetic or natural fiber mesh installed over disturbed areas to hold organic mulch and/or seed in place, Biodegradable Erosion Control Blanket-natural fiber blanket held together by netting to provide temporary erosion protection on slopes and channels, and Permanent Erosion Control Blanket-synthetic blanket material which provides permanent erosion control on slopes and channels with increased water flow velocities.

#### WHEN BMP IS TO BE INSTALLED:

Rolled erosion control products should be installed immediately after completion of a phase of grading or installation of vegetation.

#### STANDARDS AND SPECIFICATIONS:

Follow manufacturer's recommendations and specifications, particularly noting requirements for check slots, fastening devices and need for firm contact with soil.

#### OPERATION AND MAINTENANCE PROCEDURES:



Inspect at least every week and after every storm until adequate vegetation is established. Repair erosion and/or undermining at top of slope. Repair undermining beneath blankets-pull back the blanket(s), fill compact eroded area, re-vegetate and then firmly secure the blanket(s). Reposition or replace blanket(s) that have moved along the slope or have been damaged.

SITE CONDITIONS FOR REMOVAL:

Temporary blankets will generally degrade naturally; permanent blankets remain in place.

STANDARD DRAWING: EC-8a and EC-8b

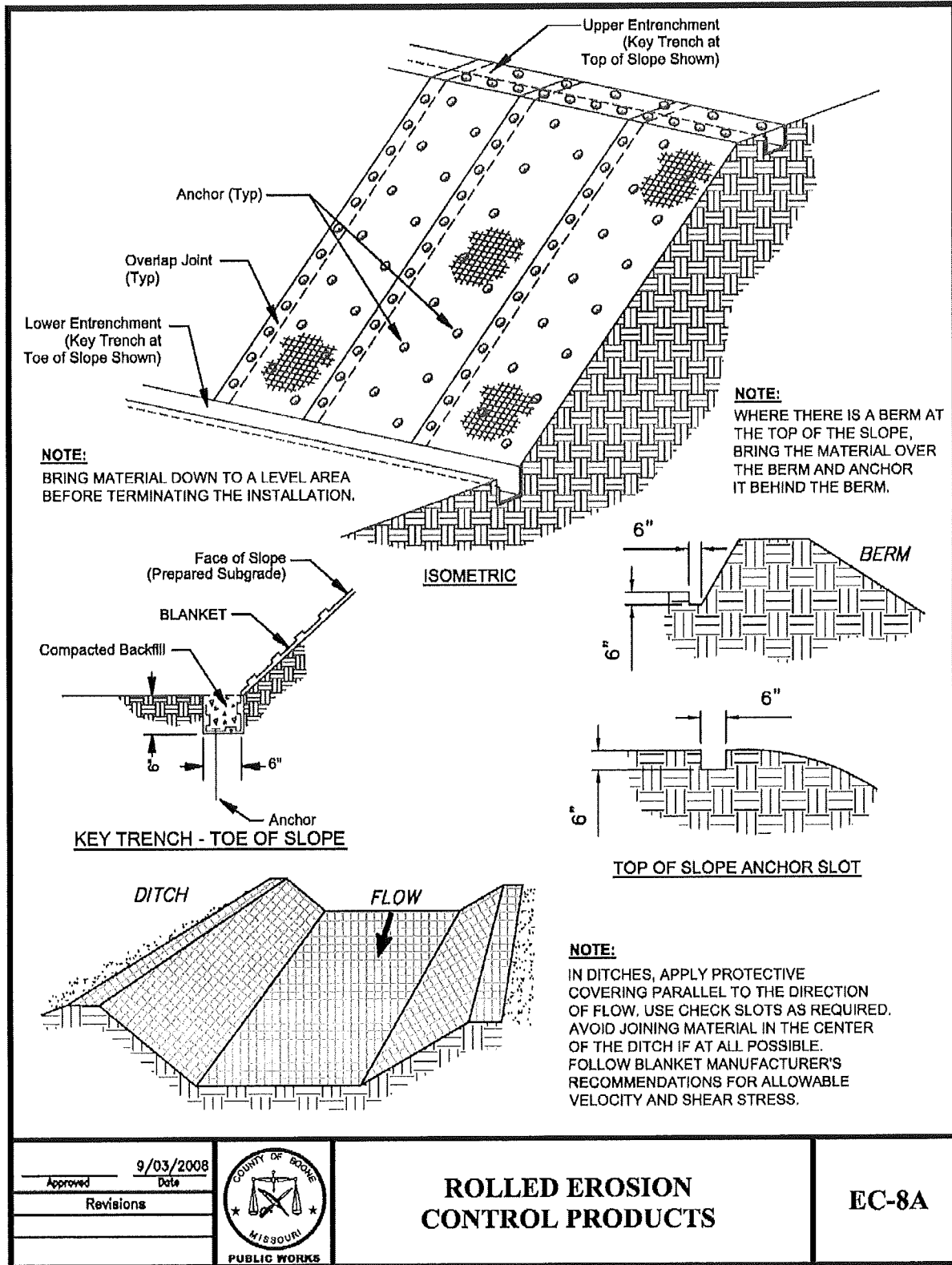



EROSION CONTROL BLANKET NOTES:

A) SITE PREPARATION:

AFTER SITE HAS BEEN SHAPED AND GRADED, PREPARE A FRIABLE SEEDBED RELATIVELY FREE FROM CLODS AND ROCKS MORE THAN 1 1/2 INCHES IN DIAMETER AND ANY FOREIGN MATERIAL THAT WILL PREVENT UNIFORM CONTACT OF THE BLANKET WITH THE SOIL SURFACE.

B) PLANTING:

LIME, FERTILIZE, AND SEED IN ACCORDANCE WITH SEEDING OR PLANTING PLAN. WHERE GROUND COVERS ARE TO BE PLANTED, LAY THE PROTECTIVE COVERING FIRST AND THEN PLANT THROUGH THE MATERIAL AS PER PLANTING PLAN.

C) LAYING AND STAPLING:

1. START LAYING THE BLANKET FROM THE TOP OF THE CHANNEL OR SLOPE AND UNROLL DOWN-GRADE. ALLOW TO LAY LOOSELY ON SOIL; DO NOT STRETCH.
2. UPSLOPE ENDS OF THE BLANKET SHOULD BE BURIED IN AN ANCHOR SLOT NO LESS THAN 6-INCHES DEEP. TAMP EARTH FIRMLY OVER THE MATERIAL.
3. WHERE MULTIPLE WIDTHS ARE LAID SIDE BY SIDE, THE ADJACENT EDGES SHALL BE OVERLAPPED A MINIMUM OF 6 INCHES AND STAPLED TOGETHER.
4. STAPLES SHALL BE PLACED PER MANUFACTURER'S RECOMMENDATIONS.

D) TROUBLESHOOTING:

- CONSULT WITH THE ENGINEER, IF ANY OF THE FOLLOWING OCCUR:
1. MOVEMENT OF THE BLANKET OR EROSION UNDER THE BLANKET IS OBSERVED.
  2. VARIATIONS IN TOPOGRAPHY ON SITE INDICATE EROSION CONTROL MAT WILL NOT FUNCTION AS INTENDED; CHANGES IN PLAN MAY BE NEEDED, OR A BLANKET WITH A SHORTER OR LONGER LIFE MAY BE NEEDED.
  3. DESIGN SPECIFICATIONS FOR SEED VARIETY, SEEDING DATES, OR EROSION CONTROL MATERIALS CANNOT BE MET; SUBSTITUTION MAY BE REQUIRED. UNAPPROVED SUBSTITUTIONS COULD RESULT IN FAILURE TO ESTABLISH VEGETATION.

E) MAINTENANCE & INSPECTION:

INSPECT CONTROLS AFTER EACH RAIN EVENT OF 1/2 INCH OR GREATER, AND EVERY 7 DAYS UNTIL VEGETATION IS ESTABLISHED. LOOK FOR EROSION OR UNDERMINING BENEATH THE NETTING, BLANKETS, OR MATS. IF ANY AREA SHOWS EROSION, PULL BACK THAT PORTION OF THE MATERIAL, ADD SOIL, AND RESEED; RESECURE THE MATERIAL IN PLACE. IF NETTING, BLANKETS OR MATS BECOME DISLOCATED OR DAMAGED, REPAIR OR REPLACE AND RESECURE IMMEDIATELY.

F) JOINING BLANKETS:

OVERLAP THE END OF THE PREVIOUS ROLL A MINIMUM OF 6 INCHES AND STAPLE. STAPLE ACROSS THE END OF THE ROLL JUST BELOW THE ANCHOR SLOT AND ACROSS THE MATERIAL EVERY 6 INCHES.

G) TERMINAL END:

AT THE POINT AT WHICH THE MATERIAL IS DISCONTINUED, OR WHERE THE BLANKET MEETS A STRUCTURE OF SOME TYPE, STAPLE A MINIMUM OF EVERY 12 INCHES.

H) FINAL CHECK:

- THESE INSTALLATION CRITERIA MUST BE ADHERED TO:
1. ALL DISTURBED AREAS ARE SEEDED.
  2. PROTECTIVE BLANKET IS IN UNIFORM CONTACT WITH THE SOIL.
  3. ALL LAP JOINTS ARE SECURE.
  4. ALL STAPLES ARE DRIVEN FLUSH WITH THE GROUND.

Approved <u>9/03/2008</u> <small>Date</small>		<b>ROLLED EROSION CONTROL PRODUCTS</b>	<b>EC-8B</b>
Revisions			
_____ _____			



## **EC-9 GEOTEXTILES AND PLASTIC COVERS**

This Best Management Practice (BMP) involves the placement of geotextiles or plastic covers to stabilize disturbed soil areas and protect soils from erosion by wind or water.

### APPROPRIATE APPLICATIONS:

Limited applications include very small graded areas and stockpiles.

### CONDITIONS FOR EFFECTIVE USE:

Type of Flow: Sheet and concentrated flows.

Geotextiles and plastic covers have maximum flow rate limitations; consult the manufacturer for proper selection. The use of plastic shall be limited to very short periods of time. The use of plastics and impermeable geotextiles results in 100% runoff, which may cause serious erosion problems in the areas receiving the increased velocities and flow. Use these products with caution. Plastic sheeting is easily vandalized, easily torn, and photodegradable.

### WHEN BMP IS TO BE INSTALLED:

Geotextiles and plastic covers should be installed immediately after completion of a phase of grading or while the stockpile is in place.

### STANDARDS AND SPECIFICATIONS:

Geotextile blankets shall be secured in place with wire staples or sandbags and by keying into tops of slopes and edges to prevent infiltration of surface water under the geotextile. Plastic sheeting shall be keyed in at the top of the slope and firmly held in place with sandbags or other weights placed no more than 10 feet apart. Seams are typically taped or weighted down their entire length. Anchoring the sheeting is crucial to keeping it in place during windy weather.

### OPERATION AND MAINTENANCE PROCEDURES:

All geotextile and plastic sheeting shall be inspected on a weekly basis and after storms to check for erosion, undermining, and anchorage failure. Any failures shall be repaired immediately. If washout or breakages occur, the material shall be re-installed after repairing the damage to the slope.

### SITE CONDITIONS FOR REMOVAL:

Upon establishment of other temporary stabilizations or after permanent stabilization has occurred.

## **EC-10 OUTLETS/VELOCITY DISSIPATION DEVICES**

These devices are placed at pipe outlets to prevent scour and reduce the velocity and/or energy of storm water flows. These devices protect the receiving area from erosion.



### APPROPRIATE APPLICATIONS:

These devices may be used at the following locations: outlets of pipes, drains, culverts, slope drains, diversion ditches, swales, conduits or channels, outlets located at the bottom of mild to steep slopes, discharge outlets that carry continuous flows of water, outlets subject to short, intense flows of water, such as flash floods, points where lined conveyances to unlined conveyances, and at emergency overflows or outlet pipes of a sediment basin.

### CONDITIONS FOR EFFECTIVE USE:

Type of Flow: Concentrated flow

### WHEN BMP IS TO BE INSTALLED:

Energy dissipation devices should be installed with the construction of the upstream BMP or pipe that creates a concentrated discharge.

### STANDARDS AND SPECIFICATIONS:

Install riprap, concrete apron, etc. at selected outlet. Riprap aprons are best suited for temporary use during construction. Carefully place riprap to avoid damaging the filter fabric. Align the apron with the receiving stream and keep straight throughout its length. If a curve is needed to fit site conditions, place it in the upper section of the apron. If the size of the apron riprap is comprised of large rocks, protect the underlying filter fabric with a gravel blanket. Outlets on slopes steeper than 10% need additional protection.

### OPERATION AND MAINTENANCE PROCEDURES:

Inspect at least every week and after every storm during construction. Remove sediment and trash accumulation. Inspect apron for displacement of the riprap and/or damage to the underlying fabric. Repair fabric and replace riprap that has washed away. Inspect for scour beneath the riprap and around the outlet. Repair damage to slopes immediately, extend the pad or place larger rock, as needed.

### SITE CONDITIONS FOR REMOVAL:

Temporary devices need to be completely removed as soon as the surrounding drainage area has been stabilized, or at the completion of construction.

### STANDARD DRAWING: EC-10

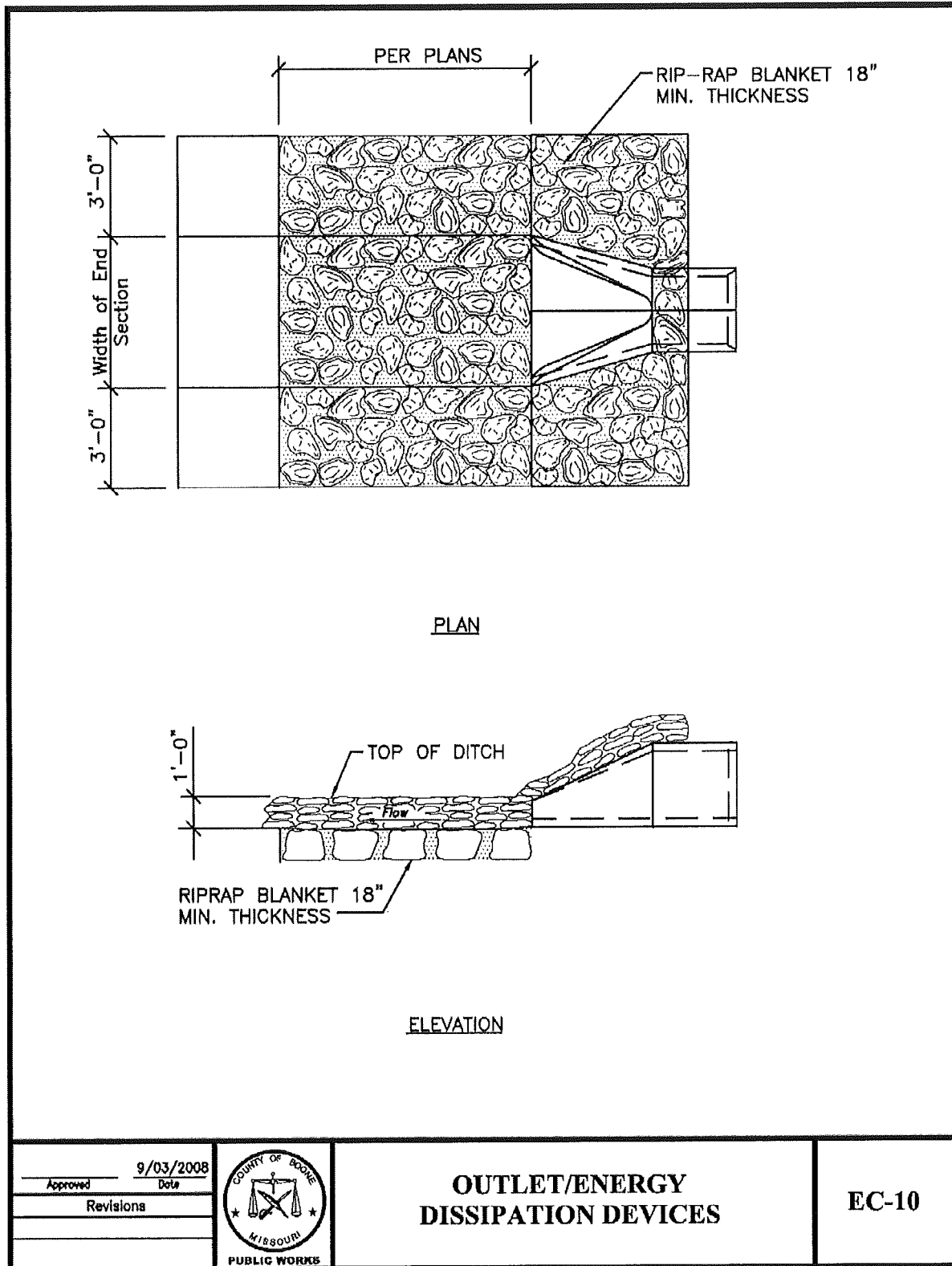



## **EC-11 TEMPORARY STREAM CROSSING**

A temporary stream crossing is a structure placed across a waterway that allows vehicles to cross the waterway during construction, minimizing, reducing, or managing erosion and downstream sedimentation caused by the vehicles. Use of temporary stream crossings is discouraged. Crossings are a direct source of pollution and should be avoided if alternatives are feasible.

### APPROPRIATE APPLICATIONS:

Temporary stream crossings are installed at sites: where appropriate permits have been secured (404, 401, etc.), where construction equipment or vehicles need to frequently cross a waterway, when alternate access routes impose significant constraints, and where construction activities will be less than 1 year.

### CONDITIONS FOR EFFECTIVE USE:

Design considerations include: current and proposed watershed conditions, average and peak discharge (2 year, 24 hour storm), effect on water surface elevation off-site, velocity, sediment removal, and protection of fish and trees. Criteria for a Low Water Crossing includes: any constant flow less than 3" deep, light traffic, bank height less than 5 feet, and perpendicular to flow or with a slight upstream arc. Criteria for a culvert crossing includes: sized for 2 year, 24 hour storm with 1 foot freeboard and no flooding of offsite areas, pipe parallel to flow, embankment perpendicular to channel or with a slight upstream arc, riprap on exposed faces sized for overtopping during a peak storm period.

### WHEN BMP IS TO BE INSTALLED:

The temporary stream crossing should be constructed during dry periods and may require dewatering or temporary diversion of the stream.

### STANDARDS AND SPECIFICATIONS:

Procedures are specific to the type of crossing used. Generally, provide a stable means to bypass normal channel flow prior to disturbing channel, stabilize channel bottom, install culvert (if used), grade and compact access ramps and soil embankment, install fabric, stone, and riprap according to design.

### OPERATION AND MAINTENANCE PROCEDURES:

Inspect every week and after every storm-checking for: blockage in the channel, debris buildup, erosion of abutments, channel scour, riprap displacement, piping of soil, and structural weakening. Remove sediment and trash accumulation. Repair and stabilize eroded areas-extend riprap if necessary.

### SITE CONDITIONS FOR REMOVAL:



Remove as soon as alternative access is available. All foreign materials should be removed from creek. The streambed/banks should be returned to the original contour and stabilized if necessary.

STANDARD DRAWING: EC-11a and EC-11b

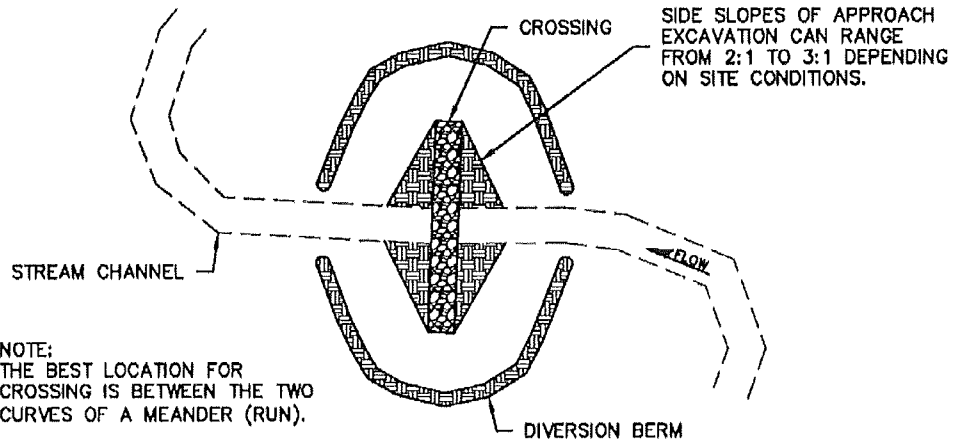

**REINFORCED STREAM CROSSING LAYOUT**  
NOT TO SCALE

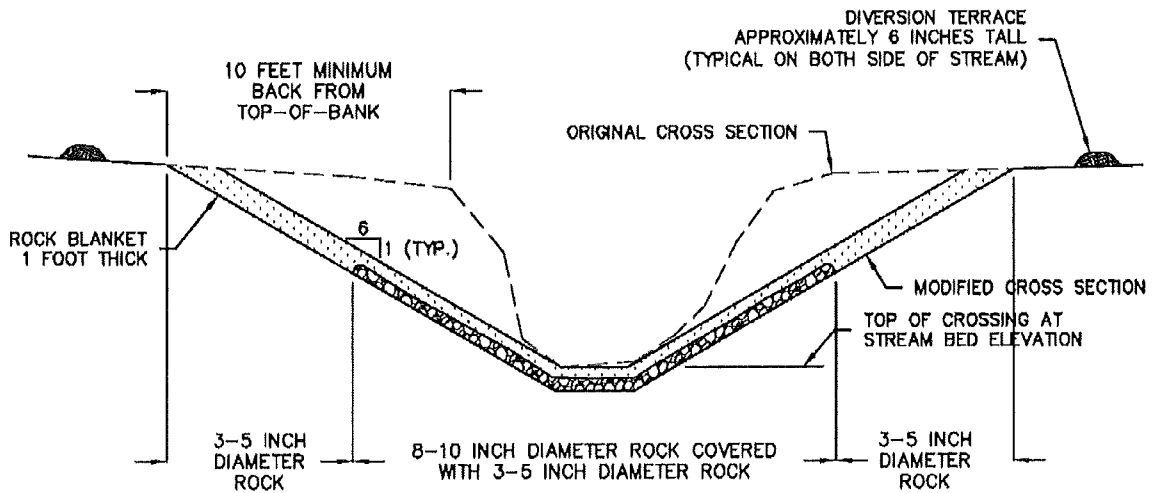

**REINFORCED STREAM CROSSING PROFILE**  
NOT TO SCALE

Approved _____ Date <b>9/03/2008</b> Revisions _____ _____ _____		<b>REINFORCED STREAM CROSSING</b>	<b>EC-11A</b>
---	--	-----------------------------------	---------------



GENERAL NOTES AND SPECIFICATIONS FOR TEMPORARY (REINFORCED) STREAM CROSSINGS:

1. THE STREAM BED FOR 0.5 MILE BELOW THE PROPOSED CROSSING MUST BE VERTICALLY STABLE. THE CHANNEL SHOULD NOT BE DOWNCUTTING (NO HEADCUTS DOWNSTREAM) OR RAPIDLY FILLING WITH SEDIMENT.
2. LOW FLOW WATER DEPTH SHALL BE LESS THAN SIX INCHES.
3. STREAM BANKS IN THE VICINITY (0.25 MILES UPSTREAM AND DOWNSTREAM) MUST BE STABLE.
4. THE CROSSING SHOULD BE LOCATED IN THE STRAIGHT REACH BETWEEN TWO BENDS.
5. APPROACHES SHOULD BE NO STEEPER THAN 6:1.
6. THE APPROACHES AND CROSSING SHOULD BE OVER EXCAVATED ONE FOOT THAN THE DESIRED SURFACE.
7. THE CROSSING AND THE APPROACHES FOR 10 FEET ON EITHER SIDE OF THE CROSSING SHOULD BE BACKFILLED WITH 8-10 INCH DIAMETER ROCK OR QUARRY RUN SHOT-ROCK TO WITHIN THREE TO FIVE INCHES OF THE DESIRED SURFACE. THE LARGE ROCK SHOULD BE COMPACTED INTO THE STREAM BED AND THE APPROACHES.
8. AFTER THE LARGE ROCK IS COMPACTED, THREE TO FIVE INCH DIAMETER ROCK SHOULD BE PLACED IN THE REMAINDER OF THE APPROACHES AND OVER THE LARGE ROCK TO PROVIDE A RELATIVELY SMOOTH SURFACE.
9. FINAL ELEVATION OF THE PORTION OF THE CROSSING SUBMERGED AT LOW FLOW SHALL NOT BE MORE THAN THREE INCHES ABOVE STREAM BED ELEVATION.
10. SIDE SLOPES OF THE APPROACH CAN RANGE FROM 2:1 TO 3:1 DEPENDING ON CONDITIONS AT THE SITE.
11. SIX INCH TALL DIVERSION BERM SHOULD BE BUILT AROUND THE CROSSING TO PREVENT OVERLAND FLOW FROM ERODING THE APPROACHES. THE DIVERSIONS SHOULD OUTLET AT STABLE LOCATIONS.
12. GROUTING (POURING CONCRETE OVER ROCK) IS PROHIBITED.
13. THE CROSSING SHOULD BE INSPECTED AFTER EACH FLOOD. BE ALERT FOR SIGNIFICANT SCOUR DOWNSTREAM OF THE CROSSING. THE SMALL DIAMETER ROCK MAY HAVE TO BE REPLACED OVER TIME. FREQUENT CLEARING OF SEDIMENT AND DEBRIS FROM THE APPROACHES WILL BE NECESSARY.

	9/03/2008 <small>Approved      Date</small>	 <b>REINFORCED STREAM CROSSING</b>	<b>EC-11B</b>
	Revisions		



## **RM-1 CHECK DAMS**

Check dams reduce scour and channel erosion by reducing flow velocity and encouraging sediment settlement. A check dam is a small device constructed of rock, gravel bags, sandbags, fiber rolls, or other proprietary product placed across a natural or man-made channel or drainage ditch.

### APPROPRIATE APPLICATIONS:

Check dams can be placed at intervals along drainage swales or channels. The top of the downstream check dam should be level with the base of the upstream check dam. Check dams can also be used during the establishment of grass linings in drainage ditches or channels or in temporary ditches where the short length of service does not warrant establishment of erosion-resistant linings. Not to be used in streams.

### CONDITIONS FOR EFFECTIVE USE:

Type of Flow: Moderate concentrated flow.

### WHEN BMP IS TO BE INSTALLED:

Check dams can be installed prior to disturbance of natural vegetation in the contributing drainage area or immediately after construction of a drainage way.

### STANDARDS AND SPECIFICATIONS:

Check dams should be placed at a distance and height to allow small pools to form behind them. Install the first check dam approximately 16 feet from the outfall device and at regular intervals based on slope gradient and soil type. For multiple check dam installation, backwater from the downstream check dam should reach the toe of the upstream dam. High flows (typically a 2-year storm or larger) should safely flow over the check dam without an increase in upstream flooding.

### OPERATION AND MAINTENANCE PROCEDURES:

Inspect at least every week and after every storm. Remove trash and leaf accumulation. Remove sediment when depth reaches one-half of the check dam height. Repair/restore dam structure, if necessary, to original configuration to protect the banks.

### SITE CONDITIONS FOR REMOVAL:

Remove after contributing areas have been adequately stabilized and vegetation is adequately established in drainage way. Regrade and vegetate the area.

### STANDARD DRAWING: RM-1

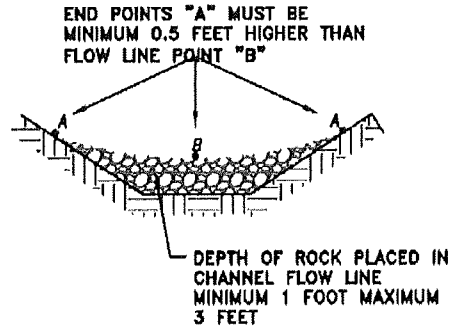
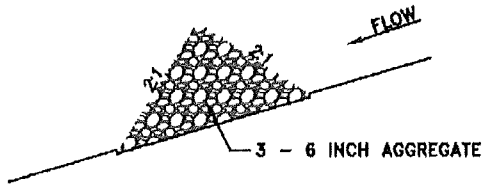

FRONT VIEW

PLACE DOWNSTREAM STRUCTURE SUCH THAT POINT "B" IS APPROXIMATELY LEVEL WITH THE TOE ELEVATION OF THE UPSTREAM STRUCTURE

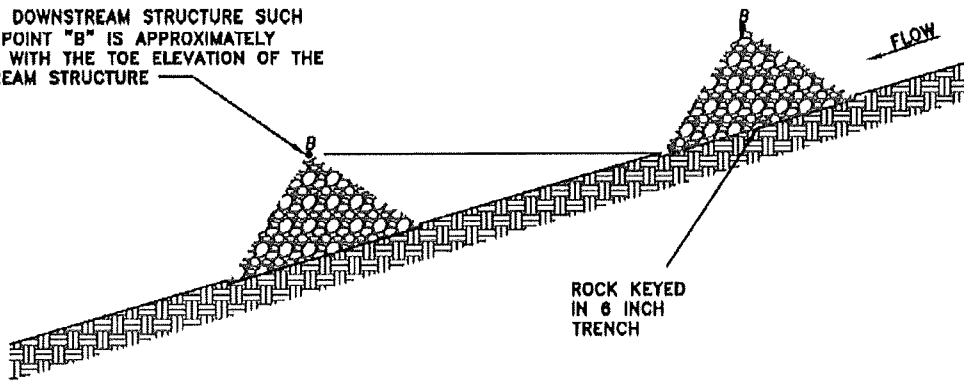

SIDE VIEW

**NOTE:**

ROCK CHECK DAMS SHALL BE USED ONLY FOR DRAINAGE AREAS LESS THAT 10 ACRES UNLESS APPROVED BY THE ENGINEER.

	9/03/2008 <small>Approved Date</small>	<b>CHECK DAMS</b>	<b>RM-1</b>
	Revisions		



## **RM-2 EARTH BERMS AND DRAINAGE SWALES**

A compacted earth, compost or gravel ridge, excavated channel or a combination of ridge and channel designed to direct runoff away from or around disturbed areas. Diversions built on a level contour are used in combination with temporary slope drains to provide adequate conveyance. Diversions built with positive drainage slopes release runoff into additional BMPs, such as sediment traps or level spreaders.

### APPROPRIATE APPLICATIONS:

These features may be used to: convey surface runoff down sloping land, intercept and divert runoff to avoid sheet flow over sloped surfaces, divert and direct runoff towards a stabilized watercourse, drainage pipe or channel, intercept runoff from paved surfaces. Berms, swales, and lined ditches also may be used: below steep grades where runoff begins to concentrate, along roadways and facility improvements subject to flood drainage, at the top of slopes to divert runoff from adjacent or undisturbed slopes and at bottom and mid-slope locations to intercept sheet flow or to convey concentrated flows.

### CONDITIONS FOR EFFECTIVE USE:

Type of Flow: Sheet flow and low-volume concentrated flows.

Contributing Area: Contributing slope length-300 feet maximum; 100 feet for slopes greater than 5%.

### WHEN BMP IS TO BE INSTALLED:

Berms and/or swales should be installed prior to disturbance of natural vegetation on slopes and at intervals during construction of fill slopes.

### STANDARDS AND SPECIFICATIONS:

Care must be applied to correctly size and locate berms, swales, and ditches. Excessively steep, unlined berms and swales are subject to gully erosion. Grade and compact the channel and/or ridge. Provide stabilized outfall areas. Conveyances should be stabilized with vegetation or a protective lining. Other BMPs, such as check dams and erosion control blankets, may be necessary to prevent scour and erosion.

### OPERATION AND MAINTENANCE PROCEDURES:

Inspect at least every week and after every storm. Inspect channel linings, embankments, and beds of ditches and berms for erosion and accumulation of debris and sediment. Remove debris and sediment, repair linings and embankments as needed-replace riprap, linings or soil stabilizers as needed.

### SITE CONDITIONS FOR REMOVAL:

Temporary diversions should be removed as soon as the surrounding drainage area has been stabilized.

### STANDARD DRAWING: RM - 2



10% SETTLEMENT

FREE BOARD  
(MIN. PER PLANS)

DESIGN FLOW DEPTH

**NOTES:**

1. TEMPORARY DIVERSION BERMS MUST BE INSTALLED AS A FIRST STEP IN THE LAND-DISTURBING ACTIVITY AND MUST BE FUNCTIONAL PRIOR TO LAND DISTURBANCE.
2. THE OUTLET OF THE DIVERSION SHALL BE LOCATED IN AN UNDISTURBED OR STABILIZED AREA.
3. TEMPORARY OR PERMANENT SEEDING AND MULCH SHALL BE APPLIED TO THE BERM IMMEDIATELY FOLLOWING ITS CONSTRUCTION.
4. ALL TREES, BRUSH, STUMPS, OBSTRUCTIONS, AND OTHER OBJECTIONABLE MATERIAL SHALL BE REMOVED AND DISPOSED OF SO AS NOT TO INTERFERE WITH THE PROPER FUNCTIONING OF THE DIVERSION.
5. THE DIVERSION SHALL BE EXCAVATED OR SHAPED TO LINE, GRADE, AND CROSS-SECTION AS REQUIRED AND FREE OF IRREGULARITIES WHICH WILL IMPEDE FLOW.
6. FILLS SHALL BE COMPACTED AS NEEDED TO PREVENT UNEQUAL SETTLEMENT THAT WOULD CAUSE DAMAGE IN THE COMPLETED DIVERSION. FILL SHALL BE COMPOSED OF SOIL WHICH IS FREE FROM EXCESSIVE ORGANIC DEBRIS, ROCKS, OR OTHER OBJECTIONABLE MATERIALS.
7. ALL EARTH REMOVED AND NOT NEEDED IN CONSTRUCTION SHALL BE SPREAD OR DISPOSED OF SO THAT IT WILL NOT INTERFERE WITH THE FUNCTIONING OF THE DIVERSION.
8. THE BERM SHOULD BE ADEQUATELY COMPACTED TO PREVENT FAILURE.
9. THE BERM SHOULD BE LOCATED TO MINIMIZE DAMAGES BY CONSTRUCTION OPERATIONS AND TRAFFIC.

<table border="1" style="width: 100%; border-collapse: collapse;"> <tr> <td style="width: 50%; text-align: center;">9/03/2008</td> <td style="width: 50%; text-align: center;">Date</td> </tr> <tr> <td style="text-align: center;">Approved</td> <td></td> </tr> <tr> <td style="text-align: center;">Revisions</td> <td></td> </tr> <tr> <td style="text-align: center;"> </td> <td></td> </tr> <tr> <td style="text-align: center;"> </td> <td></td> </tr> </table>	9/03/2008	Date	Approved		Revisions							<h2 style="margin: 0;">EARTH BERMS/ DRAINAGE SWALES</h2>	<h2 style="margin: 0;">RM-2</h2>
9/03/2008	Date												
Approved													
Revisions													



### **RM-3 TERRACING**

Terracing involves defined swales constructed at regular intervals along the face of a slope designed to reduce erosion by capturing surface runoff and directing it to an adequate, stable outlet.

#### APPROPRIATE APPLICATIONS:

Typically installed on long steep slopes on which erosion is a concern. Terraces should not be constructed in sandy or rocky soil.

#### CONDITIONS FOR EFFECTIVE USE:

Type of Flow: Sheet flow.

Slope Characteristics: Maximum of 3:1 slope.

Contributing Slope Length: Maximum of 30 feet for slopes steeper than 4:1; maximum for 50 feet for 4:1 and flatter.

#### WHEN BMP IS TO BE INSTALLED:

Terracing should be installed as fill is constructed. On existing slopes, terraces should be graded prior to removal of vegetation.

#### STANDARDS AND SPECIFICATIONS:

Grade terraces as required by the design. Construct the stable outfall as designed. Vegetate the slope and terraces immediately after BMP installation.

#### OPERATION AND MAINTENANCE PROCEDURES:

Inspect at least every week and after every storm during construction. Remove sediment accumulations along terraces. Repair settled and eroded areas. Remove sediment and stabilize eroded areas at outlet. Revegetate as needed

#### STANDARD DRAWING: RM - 3

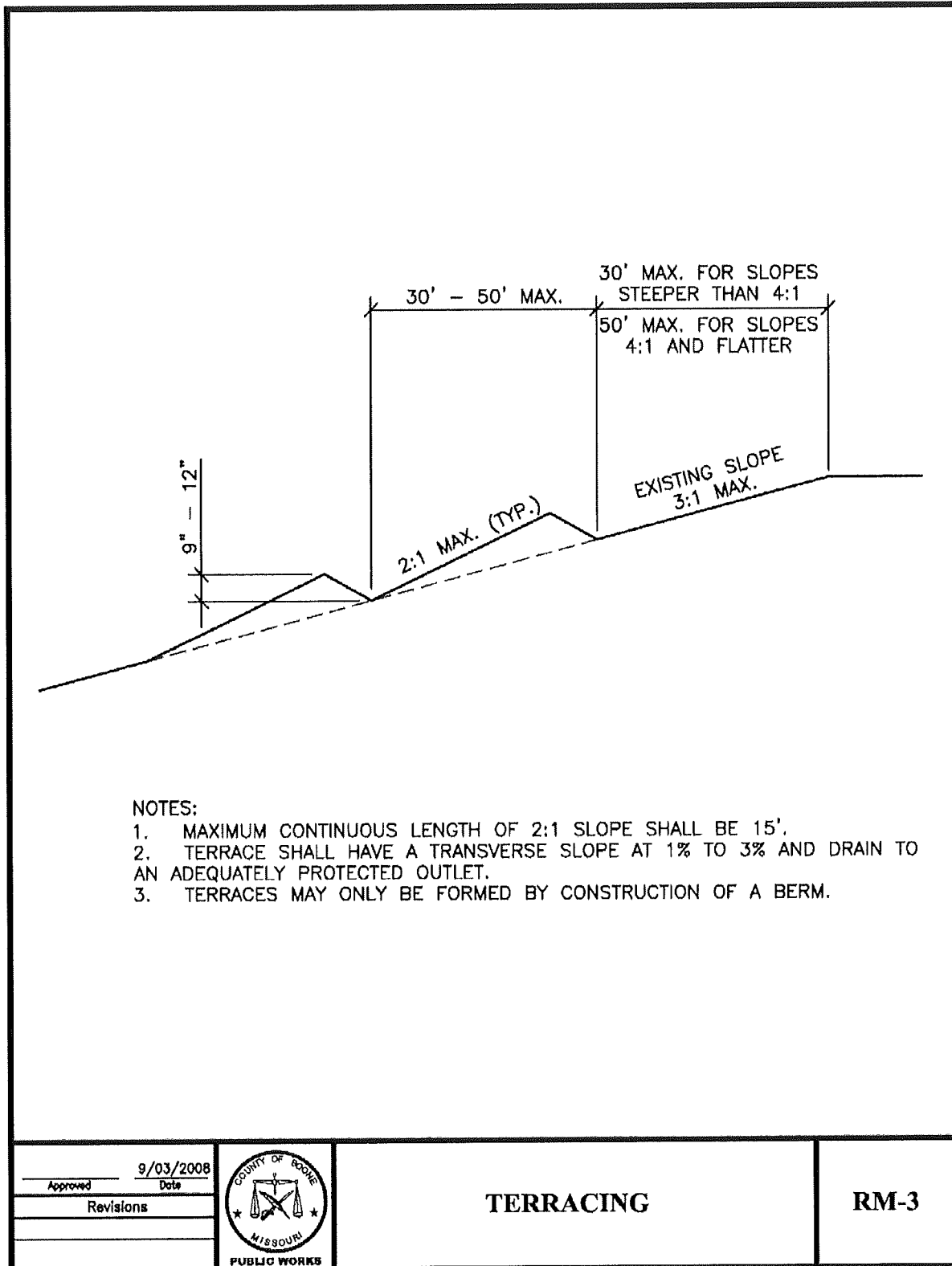



## **RM-4 SLOPE DRAINS**

A slope drain is a flexible or rigid pipe which extends from the top to the bottom of a cut or fill slope. These structures are designed to protect exposed slopes from upstream runoff and can be used with other BMPs to intercept and direct surface flow away from disturbed slope areas. Slope drains typically extend beyond the toe of the slope to a stable area or outlet.

### APPROPRIATE APPLICATIONS:

Slope drains may be used on construction sites where slopes may be eroded by surface runoff.

### CONDITIONS FOR EFFECTIVE USE:

Type of Flow: Sheet flow and concentrated flow. Contributing Area: Maximum of 5 acres per slope drain; pipe sized for 15 year, 20 minute storm.

### WHEN BMP IS TO BE INSTALLED:

Slope drains should be installed concurrently with diversion devices as soon as cut and fill operations have occurred.

### STANDARDS AND SPECIFICATIONS:

Slope drains must be installed and maintained properly because failure will usually result in severe erosion of the slope. Other points of concern are failure from overtopping due to inadequate pipe inlet capacity or blockage, and lack of maintenance of the upstream diversion device capacity. Generally install slope drain down the slope-perpendicular to slope contours, extending beyond toe of slope. Install flared end or t-section at pipe inlet. Section should be well entrenched and stable so water can enter freely. Place compacted fill over and around pipe in the area of diversion device. Ensure that all pipe connections are secure. Securely anchor the exposed section of the drain with stakes. Install flared end section at pipe outlet-discharge into a sediment trap or other stabilized outlet. Protect area around inlet with filter fabric. Protect outlet with riprap or other energy dissipation device.

### OPERATION AND MAINTENANCE PROCEDURES:

Inspect at least every week and after every storm during construction. Remove sediment and trash accumulation at inlet. Repair settlement, cracking, or piping holes. Repair leaks or inadequate anchoring along pipe. Remove sediment and stabilize eroded areas at outlet-extend if necessary.

### SITE CONDITIONS FOR REMOVAL:

Remove concurrently with upstream diversion device after slope has been stabilized. Stabilize the exposed areas where the slope drain and diversion device were removed.

### STANDARD DRAWING: RM - 4

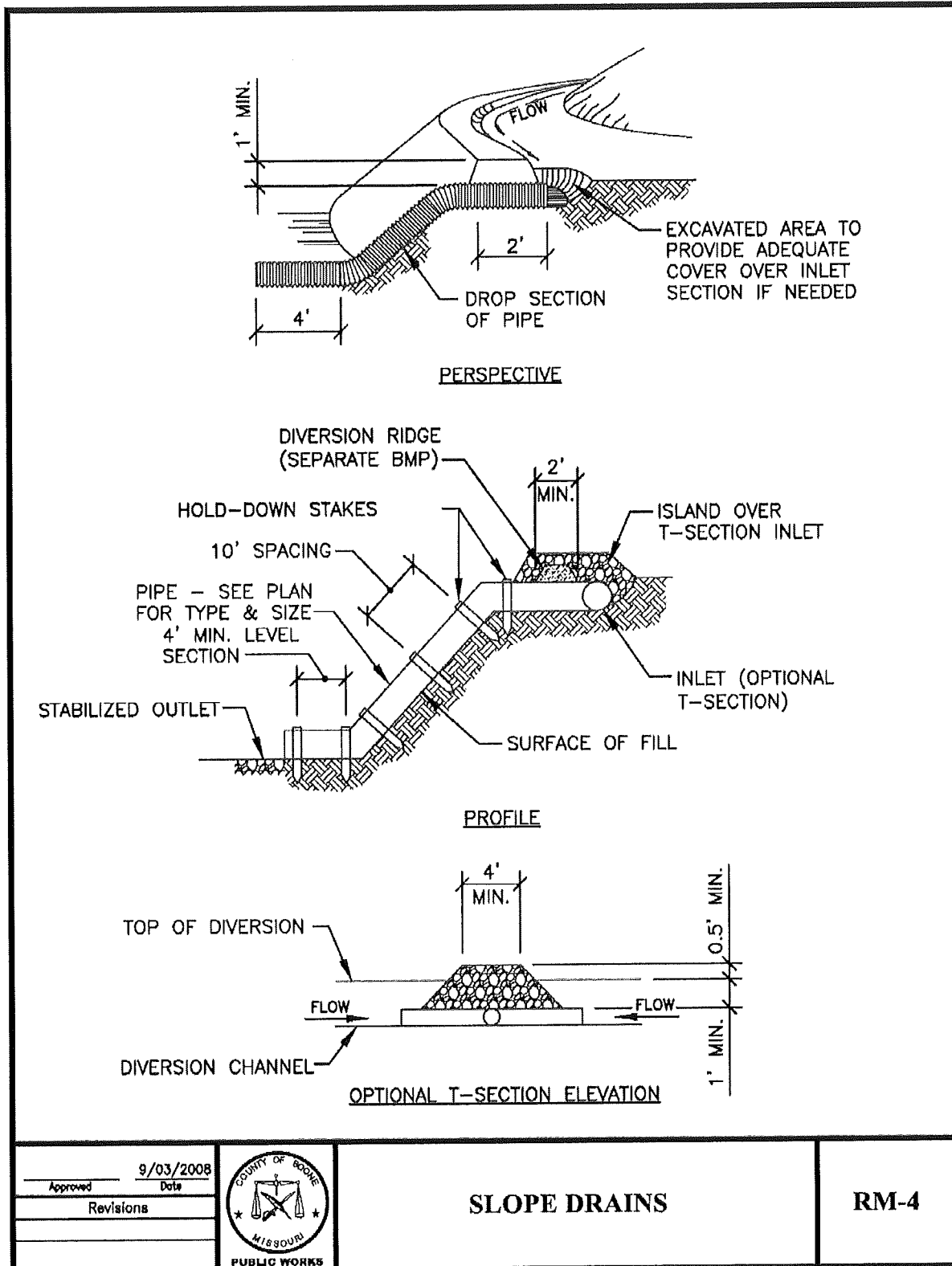

Approved	9/03/2008
	Date
Revisions	



**SLOPE DRAINS**

**RM-4**



## **RM-5 SOIL ROUGHENING**

Soil roughening is a temporary erosion control practice often used in conjunction with grading. Soil roughening involves increasing the relief of a bare soil surface with horizontal grooves by either stair-stepping (running parallel to the contour of the land) or using construction equipment to track the surface. Slopes that are not fine graded and left in a roughened condition can reduce erosion by reducing runoff velocity, increasing infiltration, trapping sediment and preparing the soil for seeding and planting by giving seed an opportunity to take root and grow.

### APPROPRIATE APPLICATIONS:

Soil roughening is appropriate for all slopes, but works especially well on slopes greater than 3:1, on piles of excavated soil, and in areas with highly erodible soils. This technique is especially appropriate for soils that are frequently disturbed, because roughening is relatively easy.

### CONDITIONS FOR EFFECTIVE USE:

Type of Flow: Sheet flow.

Contributing Area: Unlimited on slopes <10%, slopes >10% require additional BMPs

### WHEN BMP IS TO BE INSTALLED:

Soil roughening should be done immediately after rough grading; prior to seeding or mulching.

### STANDARDS AND SPECIFICATIONS:

Methods for roughening soil differ depending on the type of slope and the available equipment. These methods include stair-step grading, grooving, and tracking. When choosing a method, consider factors such as slope steepness, mowing requirements, whether the slope is formed by cutting or filling, and available equipment. Soil roughening is not appropriate for rocky slopes. Tracked machinery can excessively compact the soil, therefore lightweight machinery should be used.

### OPERATION AND MAINTENANCE PROCEDURES:

Inspect at least every week and immediately after every storm. Rework the slope and regroove after sediment buildup is deeper than ½ the groove depth, or if rills have formed across the roughened surface.

### SITE CONDITIONS FOR REMOVAL:

The slope should be reworked to the design grades prior to final stabilization.



## **RM-6 FIBER ROLLS/WATTLES**

Fiber rolls (also called fiber logs or straw wattles) are tube-shaped erosion-control devices filled with straw, flax, rice, coconut fiber material, or composted material. Each roll is wrapped with UV-degradable polypropylene netting for longevity or with 100 percent biodegradable materials like burlap, jute, or coir. These devices reduce erosion on long or steep slopes by breaking up the slope length.

### APPROPRIATE APPLICATIONS:

Fiber rolls can be used in areas of low shear stress such as; along the toe, top, face, and at-grade breaks of exposed and erodible slopes to shorten slope length and spread runoff as sheet flow, at the end of a downward slope where it transitions to a steeper slope, along the perimeter of a project or stockpile, as check dams in unlined ditches, and downslope of exposed soil areas.

### CONDITIONS FOR EFFECTIVE USE:

Type of Flow: Sheet flow and concentrated flow.

### WHEN BMP IS TO BE INSTALLED:

Wattles should be installed immediately after rough grading; prior to seeding or mulching.

### STANDARDS AND SPECIFICATIONS:

On slopes, install fiber rolls along the contour with a slight downward angle at the end of each row to prevent ponding at the midsection. Turn the ends of each fiber roll upslope to prevent runoff from flowing around the roll. Determine the vertical spacing for slope installations on the basis of the slope gradient and soil type. A good rule of thumb is: 1:1 slopes=10 feet apart, 2:1 slopes=20 feet apart, 3:1 slopes=30 feet apart, and 4:1 slopes=40 feet apart. Stake fiber rolls securely into the ground and orient them perpendicular to the slope. Fiber rolls can also be used at projects with minimal slopes. Typically, the rolls are installed along sidewalks, on the bare lot side, to keep sediment from washing onto sidewalks and streets and into gutters and storm drains.

### OPERATION AND MAINTENANCE PROCEDURES:

Inspect at least every week and after every storm. Remove sediment accumulation when it reaches  $\frac{1}{2}$  the height of the roll/wattle. Repair or replace split, torn, unraveled, or slumping fiber rolls.

### SITE CONDITIONS FOR REMOVAL:

Fiber rolls are typically left in place on slopes. If they are removed after stabilization has been achieved, collect and dispose of the accumulated sediment.

### STANDARD DRAWING: RM-6

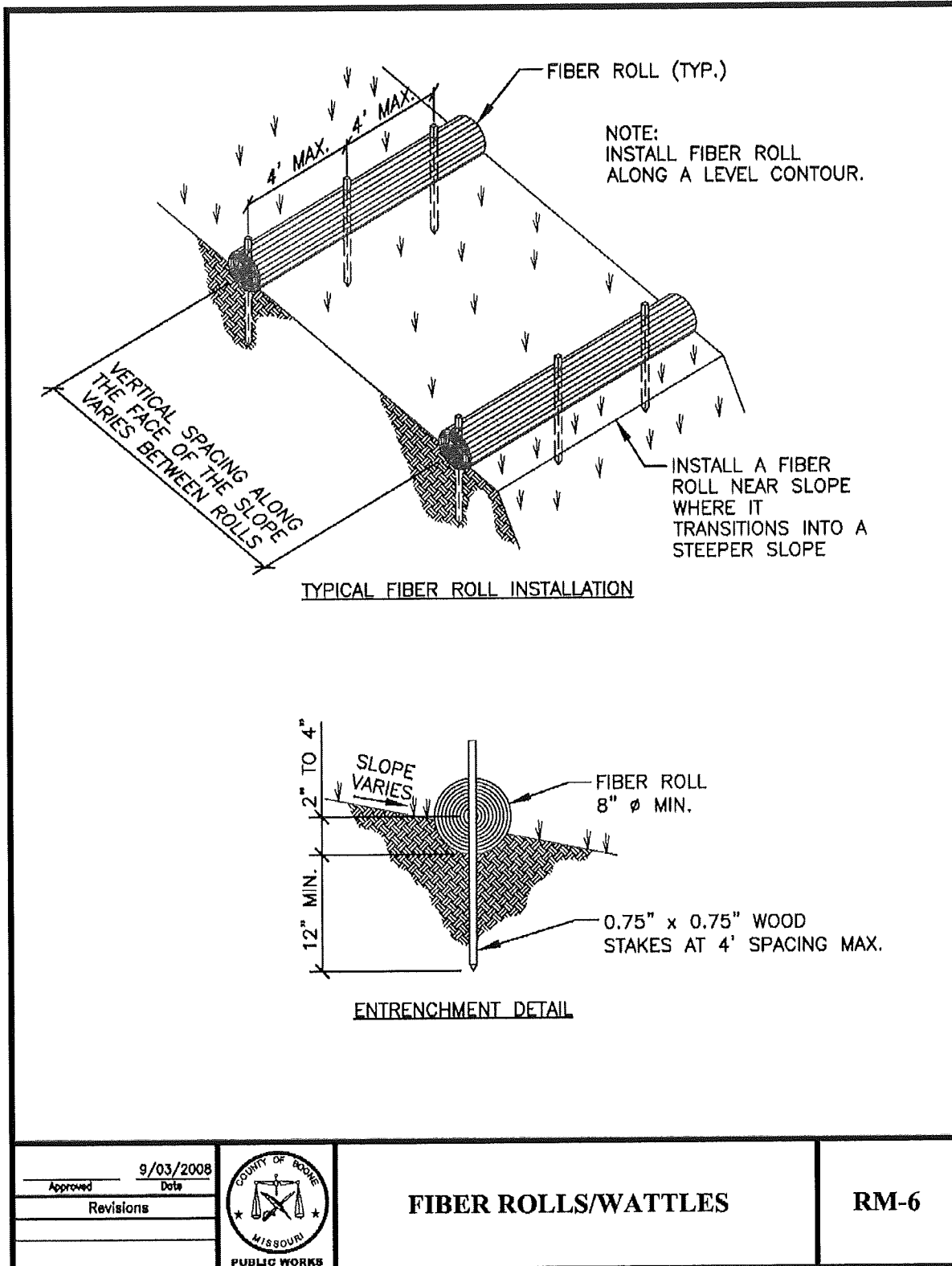



## **SC-1 VEGETATED FILTER STRIP**

Vegetated filter strips or buffers are areas of natural or established vegetation maintained to protect the water quality of neighboring areas. Buffer zones slow stormwater runoff, provide an area where runoff can permeate the soil, contribute to ground water recharge, and filter sediment. Slowing runoff also helps to prevent soil erosion and streambank collapse.

### APPROPRIATE APPLICATIONS:

Vegetated buffers can be used in any area able to support vegetation. They are most effective and beneficial on floodplains, near wetlands, along streambanks, and on unstable slopes. Filter strips can be used adjacent to low or medium density residential areas on gently sloping ground.

### CONDITIONS FOR EFFECTIVE USE:

Type of Flow: Overland sheet flow only-cannot treat high velocity flows.

### WHEN BMP IS TO BE INSTALLED:

Filter strips can be established immediately after rough grading to trap sediment during construction and/or immediately after final grading as a permanent measure to control surface runoff.

### STANDARDS AND SPECIFICATIONS:

Determine buffer widths after carefully considering slope, vegetation, soils, depth to impermeable layers, runoff sediment characteristics, type and amount of pollutants, and annual rainfall. Make sure buffer widths increase as slope increases. In areas where flows are more concentrated and fast, combine buffer zones with other practices such as level spreaders, infiltration areas, or diversions to prevent erosion and rilling. Fence off any undisturbed vegetated strips to be preserved. No activity, including parking/storing vehicles or equipment, shall be permitted in the vegetated/woody strip. If a grass filter strip is constructed, it must be completed and vegetated before construction in a contributing area is started.

### OPERATION AND MAINTENANCE PROCEDURES:

Inspect at least every week and after every storm. Remove sediment accumulation once it reaches 6" in depth. Fill and compact eroded areas and reseed, mulch and fertilize or establish other vegetation in the affected areas. After improvements are complete, regrade and reseed the top edge of the filter strip to remove sediment trapped during construction and prolong the effective use of the filter strip.



## **SC-2 SILT FENCE**

A silt fence is a length of filter fabric stretched between anchoring posts spaced at regular intervals along the site at low/downslope areas. The filter fabric should be entrenched in the ground at least 6". When installed correctly and inspected frequently, silt fences encourages the ponding of runoff and can be an effective barrier to sediment leaving the site.

### APPROPRIATE APPLICATIONS:

Installed along slopes, at base of slopes, and around the perimeter of a site as a final barrier to sediment being carried off site. Silt fence should not be used in areas of concentrated flow or as check dams.

### CONDITIONS FOR EFFECTIVE USE:

Type of Flow: Sheet flow only

Contributing Area: Drainage area should not exceed 0.25 acres per 100-foot fence length.

Slope Length: The slope length above the fence should not exceed 100 feet.

### WHEN BMP IS TO BE INSTALLED:

Silt fence should be installed prior to disturbance of natural vegetation and at intervals during construction of fill slopes.

### STANDARDS AND SPECIFICATIONS:

If a standard-strength fabric is used, it can be reinforced with wire mesh behind the filter fabric. This increases the effective life of the fence. The maximum life expectancy for synthetic fabric silt fences is about 6 months, depending on the amount of rainfall and runoff. The fence should be designed to withstand the runoff from a 10-year peak storm event. Generally, drive posts for fence line, dig trench to required dimensions in front of posts for fabric burial, attach wire mesh to posts (if necessary), attach fabric to posts-allowing required length below ground level to run fabric along bottom of trench, and backfill and compact soil in trench to protect and anchor fabric. Alternate (and actually preferred) construction procedures include installing the fence by slicing it into the ground with specialized equipment.

### OPERATION AND MAINTENANCE PROCEDURES:

Inspect at least every week and after every storm. Monitor and remove sediment buildup that is deeper than ½ the fence height. Replace torn/clogged fabric; repair loose fabric. Repair unstable or broken posts. Stabilize any areas susceptible to undermining. Add additional fencing if necessary to provide adequate protection.

### SITE CONDITIONS FOR REMOVAL:

After permanent vegetation of slope is established, remove fence, regrade trench area and vegetate.



STANDARD DRAWING: SC-2a and SC-2b

1. EXCAVATE A 6"x4" TRENCH

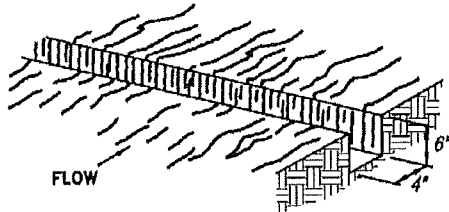

2. SET THE STAKES ALONG THE DOWN SLOPE SIDE OF THE TRENCH.

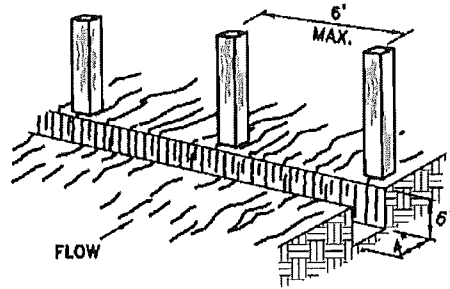

3. STAPLE GEOTEXTILE MATERIAL TO STAKES AND EXTEND IT INTO AND AROUND THE BOTTOM OF THE TRENCH.

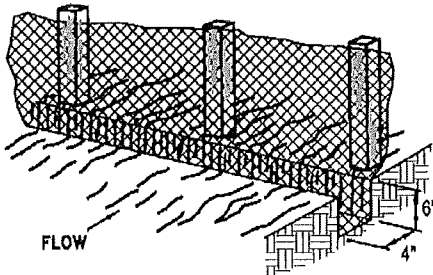

4. BACK FILL AND COMPACT THE EXCAVATED SOIL OVER THE GEOTEXTILE IN THE TRENCH.

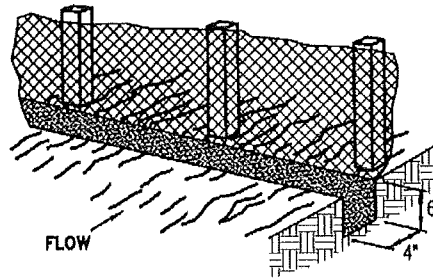

**SHEET FLOW INSTALLATION  
(PERSPECTIVE VIEW)  
NOT TO SCALE**

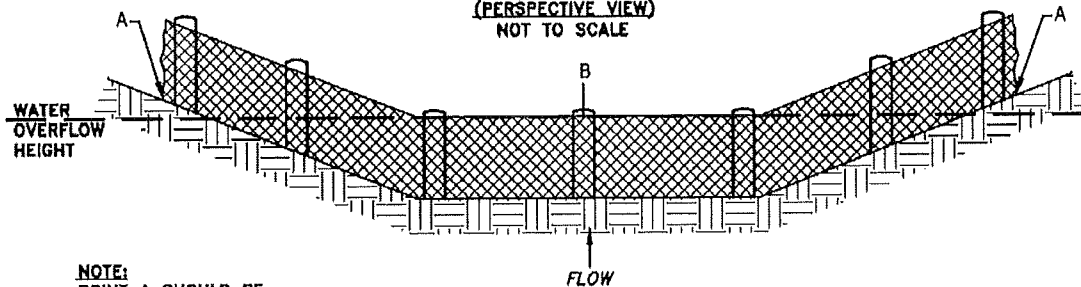

**NOTE:**  
POINT A SHOULD BE  
HIGHER THAN POINT B.

**DRAINAGE WAY INSTALLATION  
(FRONT ELEVATION)  
NOT TO SCALE**

<p>Approved _____ Date <u>9/03/2008</u></p>		<p><b>SILT FENCE</b></p>	<p><b>SC-2A</b></p>
<p>Revisions _____</p>			



**SILT FENCE NOTES:**

**A) INSTALLATION**

1. THE HEIGHT OF SILT FENCE SHALL BE A MINIMUM OF 16 INCHES ABOVE THE ORIGINAL GROUND SURFACE AND SHALL NOT EXCEED 34 INCHES ABOVE THE GROUND SURFACE.
2. THE FABRIC SHALL BE PURCHASED IN A CONTINUOUS ROLL CUT TO LENGTH OF THE BARRIER TO AVOID THE USE OF JOINTS. WHEN JOINTS ARE UNAVOIDABLE, FILTER CLOTH SHALL BE SECURELY SPLICED TOGETHER ONLY AT SUPPORT POSTS, WITH A MAX 6 INCH OVERLAP.
3. DIG A TRENCH AT LEAST 6 INCHES DEEP AND 4 INCHES WIDE ALONG THE TRENCH ALIGNMENT.
4. DRIVE POSTS AT LEAST 24 INCHES INTO THE GROUND ON THE DOWNSLOPE SIDE OF THE TRENCH. SPACE POSTS A MAXIMUM OF 6 FEET APART.
5. THE SEDIMENT FABRIC SHALL BE FASTENED SECURELY TO THE UPSLOPE SIDE OF THE POSTS USING A MINIMUM OF ONE INCH LONG, HEAVY-DUTY WIRE STAPLES OR TIE-WIRES, AND EIGHT INCHES OF THE FABRIC SHALL BE EXTENDED INTO THE TRENCH. THE FABRIC SHALL NOT BE STAPLED TO EXISTING TREES.
6. PLACE THE BOTTOM 1 FOOT OF FABRIC IN THE MINIMUM-OF-6-INCH DEEP TRENCH, LAPPING TOWARD THE UPSLOPE SIDE. BACK FILL WITH COMPACTED EARTH OR GRAVEL.
7. IF A SILT FENCE IS TO BE CONSTRUCTED ACROSS A DITCH LINE OR SWALE, IT MUST BE OF SUFFICIENT LENGTH TO ELIMINATE ENDFLOW, AND THE PLAN CONFIGURATION SHALL RESEMBLE AN ARC OR HORSESHOE, PLACED ON A CONTOUR, WITH THE ENDS ORIENTED UPSLOPE. EXTRA-STRENGTH SEDIMENT FABRIC SHALL BE USED WITH A MAXIMUM 3-FOOT SPACING OF POSTS.
8. TO REDUCE MAINTENANCE, EXCAVATE A SHALLOW SEDIMENT STORAGE AREA IN THE UPSLOPE SIDE OF THE FENCE. PROVIDE GOOD ACCESS IN AREA OF HEAVY SEDIMENTATION FOR CLEAN OUT AND MAINTENANCE.
9. SILT FENCES SHALL BE REMOVED WHEN THEY HAVE SERVED THEIR USEFUL PURPOSE, BUT NOT BEFORE THE UPSLOPE AREA HAS BEEN PERMANENTLY STABILIZED.
10. INSTALLATION WITH SLICING METHOD IS PREFERRED.

**B) TROUBLESHOOTING:**

1. DETERMINE THE EXACT LOCATION OF UNDERGROUND UTILITIES, BEFORE FENCE INSTALLATION SO UTILITIES ARE NOT DISTURBED.
2. GRADE ALIGNMENT OF FENCE NEEDED TO PROVIDE A BROAD, NEARLY LEVEL AREA UPSTREAM OF FENCE TO ALLOW SEDIMENT COLLECTION AREA.

**C) INSPECTION MAINTENANCE:**

1. INSPECT SILT FENCES AT LEAST ONCE A WEEK AND AFTER EACH 1/2" OF RAINFALL. MAKE ANY REQUIRED REPAIRS IMMEDIATELY.
2. SHOULD THE FABRIC OF A SEDIMENT FENCE COLLAPSE, TEAR, DECOMPOSE, OR BECOME INEFFECTIVE, REPLACE IT PROMPTLY.
3. REMOVE SEDIMENT DEPOSITS AS NECESSARY TO PROVIDE ADEQUATE STORAGE VOLUME FOR THE NEXT RAIN AND TO REDUCE PRESSURE ON THE FENCE, AVOID DAMAGING OR UNDERMINING THE FENCE DURING CLEANOUT. SEDIMENT ACCUMULATION SHOULD NOT EXCEED 1/2 THE HEIGHT OF THE FENCE.
4. REMOVE ALL FENCING MATERIALS AND UNSTABLE SEDIMENT DEPOSITS, AND BRING THE AREA TO GRADE AND STABILIZE IT AFTER THE CONTRIBUTING DRAINAGE AREA HAS BEEN PROPERLY AND COMPLETELY STABILIZED.

<p>9/03/2008 Approved Date</p> <p>Revisions</p>		<p><b>SILT FENCE NOTES</b></p>	<p><b>SC-2B</b></p>
---	---	--------------------------------	---------------------



### **SC-3 STRAW BALE DIKE**

A straw bale dike consists of a series of straw (or hay) bales butted firmly end to end and anchored in place with stakes placed along the low/downslope areas of a site. The straw bales should be entrenched in the ground. When installed correctly and inspected frequently, straw bale dikes encourage the ponding of runoff and can be an effective barrier to prevent sediment from leaving the site in stormwater runoff.

#### APPROPRIATE APPLICATIONS:

Installed along slopes, at base of slopes, and around the perimeter of a site as a final barrier to sediment being carried off site. Straw bale dikes should not be used in areas of significant concentrated flow as check dams.

#### CONDITIONS FOR EFFECTIVE USE:

Type of Flow: Sheet flow and minimal concentrated flow.

Contributing Area: Drainage area should not exceed 0.25 acres per 100-foot fence length. For minor swales where the dike will serve as a ditch check, the drainage area shall not exceed 2 acres.

Slope Length: The slope length above the fence should not exceed 100 feet. Reduce this as the area above the dike steepens.

#### WHEN BMP IS TO BE INSTALLED:

Straw bale dikes should be installed prior to disturbance of natural vegetation and at intervals during construction of fill slopes.

#### STANDARDS AND SPECIFICATIONS:

The maximum life expectancy for straw bale dikes is about 3 months, depending on the amount of rainfall and runoff. The dike should be designed to withstand the runoff from a 10-year peak storm event. The dike should be installed on level ground at least 10 feet from the toe of the slope. Excavate a trench at least 4" deep and a bale width wide and long enough that the end bales are upslope of the sediment pool. Anchor bales by driving two 36" long 2"x2" hardwood stakes through each bale until nearly flush with the top. Drive the first stake toward the previously laid bale to force the bales together. Wedge loose straw into any gaps between the bales. Backfill and compact the excavated soil against the bales to ground level on the downslope side and to 4" above ground level on the upslope side.

#### OPERATION AND MAINTENANCE PROCEDURES:

Inspect at least every week and after every storm. Remove sediment buildup that is deeper than ½ the dike height. Replace deteriorated or damaged bales. Repair unstable or broken stakes.



Stabilize any areas susceptible to undermining. Add additional bales if necessary to provide adequate protection.

SITE CONDITIONS FOR REMOVAL:

After permanent vegetation of slope is established, remove the dike, regrade trench area and vegetate.

STANDARD DRAWING: SC-3

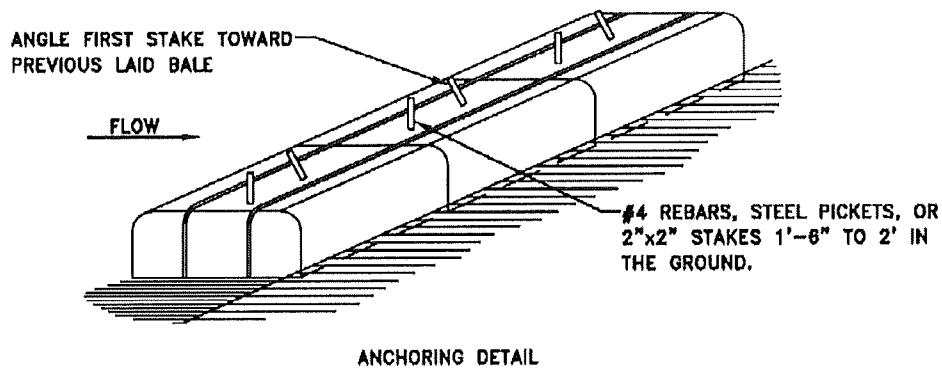
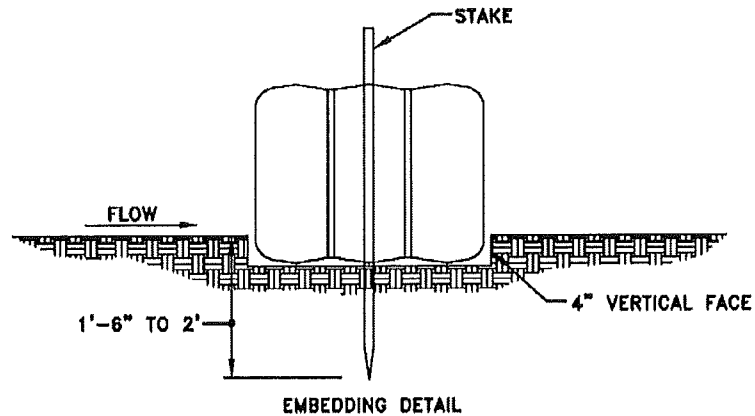

1. BALES SHALL BE PLACED IN A ROW WITH ENDS TIGHTLY ABUTTING THE ADJACENT BALES.
2. EACH BALE SHALL BE EMBEDDED IN THE SOIL A MINIMUM OF 4".
3. BALES SHALL BE SECURELY ANCHORED IN PLACE BY STAKES OR RE-BARS DRIVEN THROUGH THE BALES. THE FIRST STAKE IN EACH BALE SHALL BE ANGLED TOWARD PREVIOUSLY LAID BALE TO FORCE BALES TOGETHER.
4. INSPECTION SHALL BE AT LEAST ONCE A WEEK AND AFTER EACH 1/2" RAIN. REPAIR OR REPLACEMENT SHALL BE MADE PROMPTLY.
5. BALES SHALL BE REMOVED BY THE OWNER WHEN THEY HAVE SERVED THEIR USEFULNESS SO AS NOT TO BLOCK OR IMPEDE STORM FLOW OR DRAINAGE.

	9/03/2008 Approved Date		<h2>STRAW BALE DIKE</h2>	<h2>SC-3</h2>
	Revisions			



## **SC-4 COMPOST FILTER SOCKS**

A compost filter sock is a type of contained compost filter berm. It is a mesh tube filled with composted material that is placed perpendicular to sheet-flow runoff to control erosion and retain sediment in disturbed areas.

### APPROPRIATE APPLICATIONS:

Compost filter socks are generally placed along the perimeter of a site, or at intervals along a slope, to capture and treat stormwater that runs off as sheet flow. Filter socks can also be used on pavement as inlet protection for storm drains and as small check dams to slow water flow in small ditches. Filter socks used for erosion control are usually 12 inches in diameter, although 8 inch, 18 inch, and 24 inch– diameter socks are used in some applications.

### CONDITIONS FOR EFFECTIVE USE:

Type of Flow: Sheet flow and small concentrated flow

Contributing Area: Drainage area should not exceed 0.25 acres per 100-foot fence length.

Slope Length: The slope length above the fence should not exceed 100 feet.

### WHEN BMP IS TO BE INSTALLED:

Filter socks can be used prior to disturbance of natural vegetation and at intervals during construction of fill slopes.

### STANDARDS AND SPECIFICATIONS:

The diameter of the filter sock will vary depending upon the steepness and length of the slope. In areas of concentrated flow, filter socks are sometimes placed in an inverted V going up the slope, to reduce the velocity of water running down the slope. The project engineer may also consider placing filter socks at the top and base of the slope or placing a series of filter socks every 15 to 25 feet along the vertical profile of the slope. Generally, the filter sock is filled, put in place, and anchored using stakes, so no trenching is required. During installation, the ends of the sock should be directed upslope

### OPERATION AND MAINTENANCE PROCEDURES:

Inspect at least every week and after every storm. Remove sediment buildup that is deeper than  $\frac{1}{2}$  the filter sock height. Repair unstable or broken posts. Stabilize any areas susceptible to undermining. Add additional socks if necessary to provide adequate protection.

### SITE CONDITIONS FOR REMOVAL:

Remove the sock after permanent vegetation of slope is established. Regrade trench area and vegetate.



## **SC-5 COMPOST FILTER BERMS**

A compost filter berm is a dike of compost or a compost product that is placed perpendicular to sheet flow runoff to control erosion in disturbed areas and retain sediment. It can be used in place of a traditional control tool such as a silt fence or compost filter socks.

### APPROPRIATE APPLICATIONS:

Vegetated compost filter berms are generally placed along the perimeter of a site, or at intervals along a slope. A filter berm also can be used as a check dam in small drainage ditches.

### CONDITIONS FOR EFFECTIVE USE:

Type of Flow: Sheet flow and small concentrated flow.

Contributing Area: Drainage area should not exceed 0.25 acres per 100-foot fence length.

### WHEN BMP IS TO BE INSTALLED:

Install the compost berm prior to disturbance of natural vegetation and at intervals during construction of fill slopes.

### STANDARDS AND SPECIFICATIONS:

The compost filter berm dimensions should be modified based on site-specific conditions, such as soil characteristics, existing vegetation, site slope, and climate, as well as project-specific requirements. Generally the berms are trapezoidal in cross section with the base twice the height of the berm. The compost should be uniformly applied to the soil surface, compacted, and shaped to into a trapezoid. Compost filter berms can be installed on frozen or rocky ground. The filter berm may be vegetated by hand, by incorporating seed into the compost prior to installation, or by hydraulic seeding following berm construction.

### OPERATION AND MAINTENANCE PROCEDURES:

Inspect at least every week and after every storm. Remove sediment buildup deeper than ½ the filter berm. Any areas that have been washed away should be replaced. If the berm has experienced significant washout, the filter berm alone may not be the appropriate BMP for the area or the size of the berm may need to be increased.

### SITE CONDITIONS FOR REMOVAL:

Vegetated filter berms are normally left in place and provide long-term filtration of stormwater as a post-construction best management practice (BMP). If temporary, break down the berm once construction is complete and spread the compost around the site as a soil amendment or mulch.



## **SC-6 SEDIMENT BASIN**

A temporary settling basin designed to slowly release runoff, detaining it long enough to allow most of the sediment to settle out. Basins should be used in conjunction with additional BMPs, such as temporary seeding, to reduce the total amount of sediment washing into the structure. Sediment basins may also be designed to be converted from a temporary basin to a permanent storm water detention basin after construction has ended.

### APPROPRIATE APPLICATIONS:

Should be located as close to the sediment source as possible. A sediment basin should not be used in areas of continuously running water (live streams) nor areas where failure of the embankment will result in loss of life, damage to homes or structures, or prevent the use of roadways or utilities.

### CONDITIONS FOR EFFECTIVE USE:

Type of Flow: Sheet flow and concentrated flow.

Basin Volume: Volume of 10 year, 20 minute storm plus silt load of 1800 cf/acre below riser top.

### WHEN BMP IS TO BE INSTALLED:

Sediment basins should be placed prior to the disturbance of natural vegetation.

### STANDARDS AND SPECIFICATIONS:

For permanent structures, a qualified professional engineer experienced in designing dams should complete the basin design. Excavate basin to length, width, depth and slopes specified on plans. Place and compact fill to construct dam to elevation at least 1 foot above crown of outlet pipe. Install outlet pipe and compact clay soil around pipe. Install the perforated riser pipe, wrap with fabric, and surround with uniformly graded gravel. Install energy dissipation at downstream end of outlet pipe. Complete installation of dam to an elevation 10% above design height to allow for settling. Grade and stabilize spillway. Install monitoring post near outlet of basin. Mark maximum allowable sediment depth.

### OPERATION AND MAINTENANCE PROCEDURES:

Inspect at least every week and after every ½” storm. Remove trash accumulation at outlet. Remove sediment accumulations once sediment reaches design depth, as indicated on monitoring posts. Repair and re-vegetate any erosion damage on spillway. Repair settlement, cracking, piping holes, or seepage at embankment. Replace gravel around riser if basin does not drain properly.

### SITE CONDITIONS FOR REMOVAL:

Remove after upstream areas are stabilized. Regrade as appropriate and vegetate immediately.



STANDARD DRAWING: SC-6

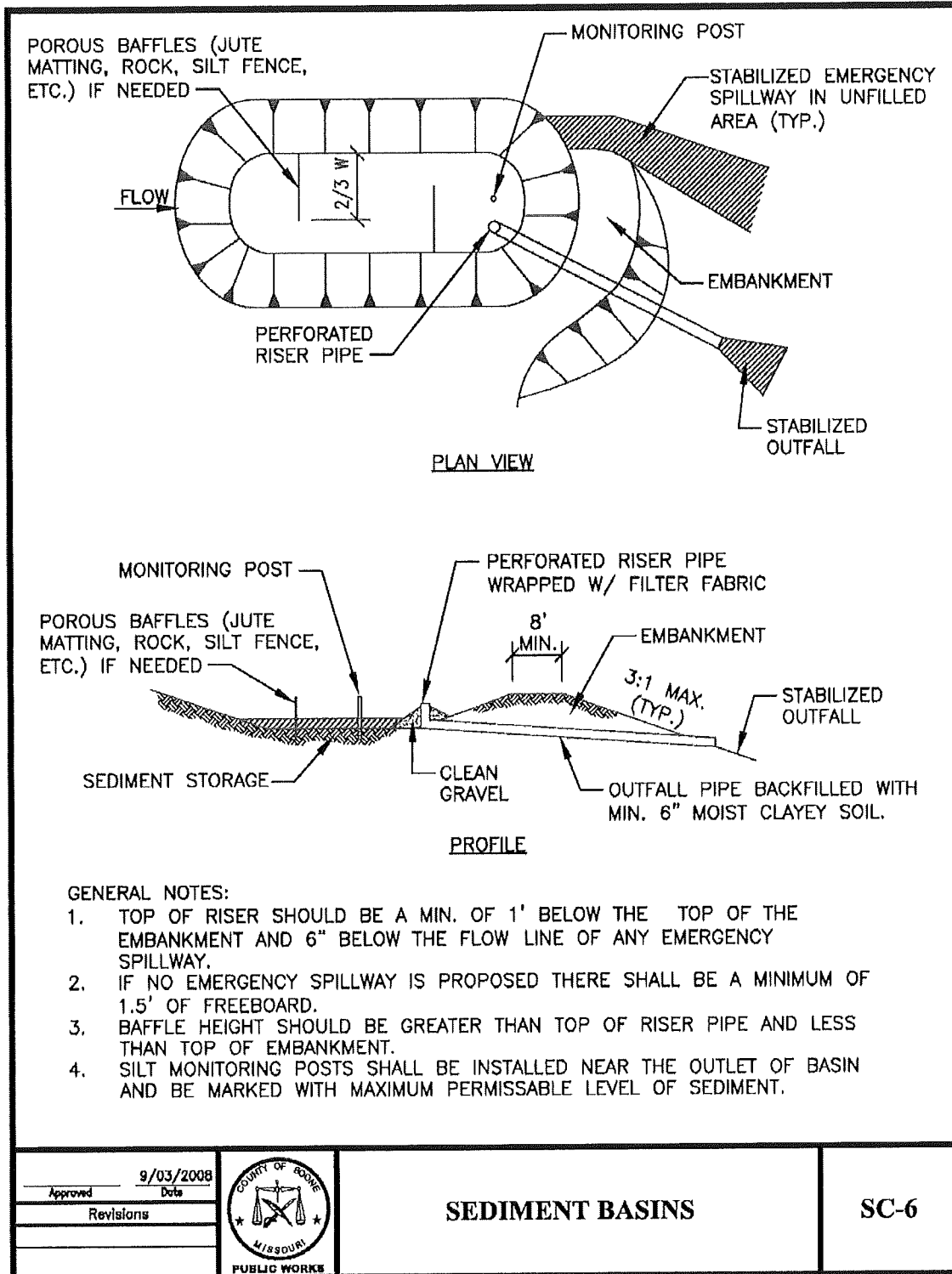



## **SC-7 SEDIMENT TRAP**

A sediment trap is a temporary containment area that allows sediment in collected storm water to settle out during infiltration or before the runoff is discharged.

### APPROPRIATE APPLICATIONS:

Sediment traps are commonly used at the outlets of stormwater diversion structures, channels, slope drains, construction site entrances, vehicle wash areas, or other runoff conveyances.

### CONDITIONS FOR EFFECTIVE USE:

Type of Flow: Sheet flow and concentrated flow.

Contributing Area: Maximum of 5 acres.

Trap Volume: Silt load of 1800 cf/acre.

### WHEN BMP IS TO BE INSTALLED:

Install sediment traps prior to disturbance of natural vegetation.

### STANDARDS AND SPECIFICATIONS:

Take care to situate sediment traps for easy access by maintenance crews. Excavate an area for the sediment trap, making sure the side slopes are no steeper than 2:1 and the embankment height no more than 5 feet from the original ground surface. Install dewatering pipe, if necessary. Place and compact fill to construct embankments and the spillway. To reduce flow rate from the trap, line the outlet with rip rap and gravel over the dewatering pipe, if necessary. The spillway weir for each temporary sediment trap should be at least 4 feet long for a 1-acre drainage area and increase by 2 feet for each additional drainage acre added, up to a maximum drainage area of 5 acres. Install monitoring posts in the trap which mark  $\frac{1}{2}$  the design depth for sediment accumulation.

### OPERATION AND MAINTENANCE PROCEDURES:

Inspect at least every week and after every  $\frac{1}{2}$ " storm. Remove trash accumulation. Remove sediment accumulations once sediment reaches design depth, as indicated on monitoring posts. Repair and revegetate any erosion damage. Repair settlement, cracking, piping holes, or seepage at embankment.

### SITE CONDITIONS FOR REMOVAL:

Remove after upstream areas are stabilized. Regrade as appropriate and vegetate immediately.

### STANDARD DRAWING: SC-7a and SC-7b

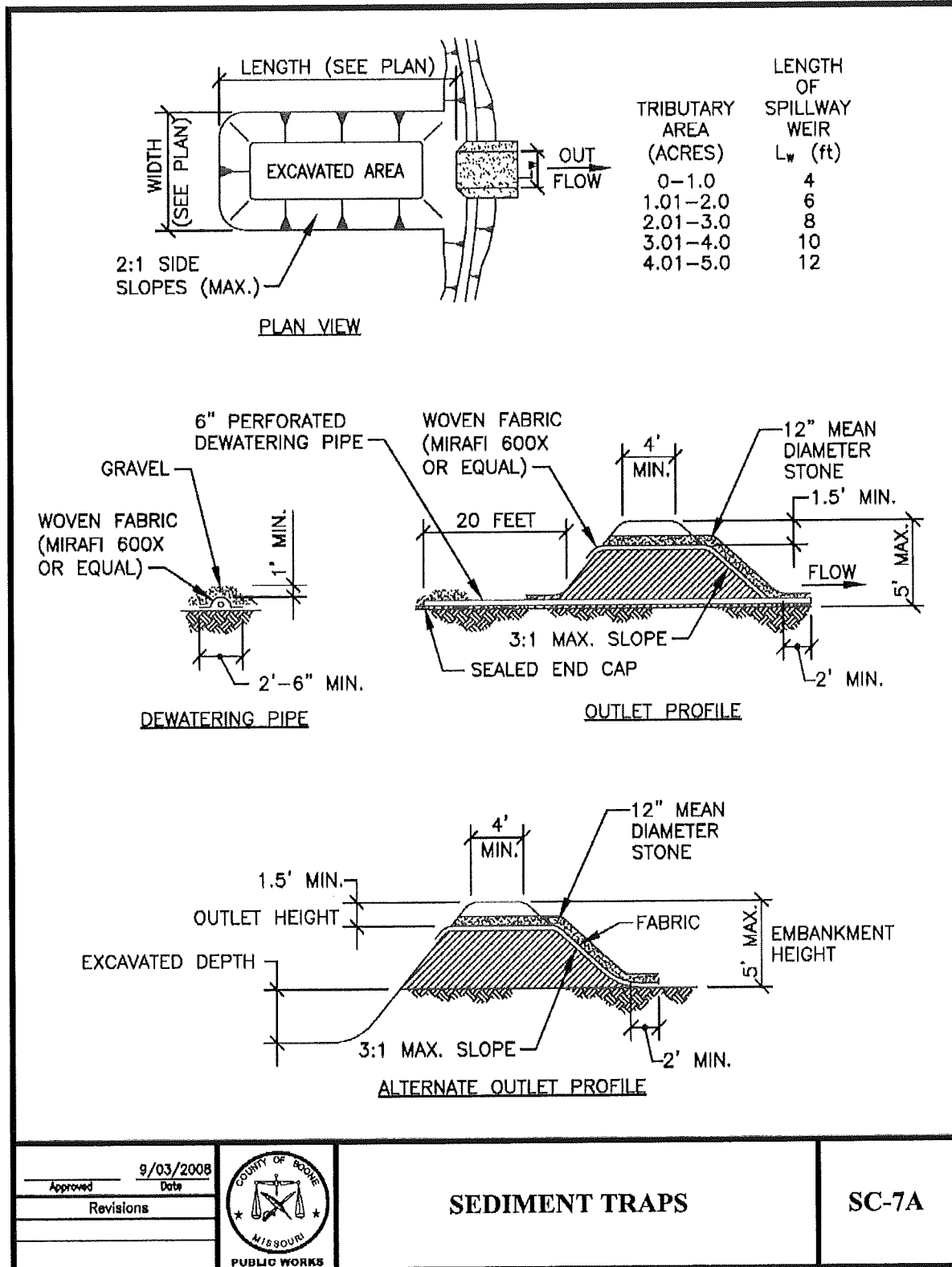

Approved	9/03/2008
Date	
Revisions	



# SEDIMENT TRAPS

SC-7A



TEMPORARY SEDIMENT TRAP NOTES:

A) CONSTRUCTION SPECIFICATIONS:

1. THE AREA UNDER THE EMBANKMENT SHALL BE CLEARED, GRUBBED, AND STRIPPED OF ANY VEGETATION AND ROOT MAT.
2. FILL MATERIAL FOR THE EMBANKMENT SHALL BE FREE OF ROOTS OR OTHER WOODY VEGETATION, ORGANIC MATERIAL, LARGE STONES, AND OTHER OBJECTIONABLE MATERIAL. THE EMBANKMENT SHOULD BE COMPACTED IN 6-INCH LAYERS BY TRAVERSING WITH CONSTRUCTION EQUIPMENT.
3. THE EARTHEN EMBANKMENT SHALL BE SEEDED WITH TEMPORARY OR PERMANENT VEGETATION IMMEDIATELY AFTER INSTALLATION
4. CONSTRUCTION OPERATION SHALL BE CARRIED OUT TO MINIMIZE EROSION AND WATER POLLUTION.
5. ALL CUT AND FILL SLOPES SHALL BE 2H:1V OR FLATTER EXCEPT FOR EXCAVATED, WET STORAGE AREAS WHICH MAY BE AT A MAXIMUM 1H:1V GRADE.

B) INSPECTION AND MAINTENANCE

1. INSPECT THE TEMPORARY SEDIMENT TRAP WEEKLY AND AFTER EACH STORM EVENT OF 1/2-INCH OR GREATER.
2. REMOVE AND PROPERLY DISPOSE OF SEDIMENT WHEN IT ACCUMULATES TO ONE-HALF THE DESIGN VOLUME.
3. PERIODICALLY CHECK THE EMBANKMENT, SPILLWAY, AND OUTLET APRON FOR EROSION DAMAGE, SETTLING SEEPAGE, OR SLUMPING ALONG THE TOE AND REPAIR IMMEDIATELY.
4. REPLACE THE SPILLWAY GRAVEL FACING IF IT BECOMES CLOGGED.
5. INSPECT VEGETATION AND RESEED IF NECESSARY.
6. REPLACE ANY DISPLACED RIPRAP SO THAT NO REPLACEMENT ROCK IS ABOVE THE DESIGN GRADE.
7. REMOVE THE TEMPORARY SEDIMENT TRAP AFTER THE DRAINAGE AREA HAS BEEN PERMANENTLY STABILIZED, INSPECTED, AND APPROVED. DO SO BY DRAINING ANY WATER, REMOVING THE SEDIMENT TO A DESIGNATED DISPOSAL AREA, AND GRADING THE SITE TO BLEND WITH THE SURROUNDING AREA; THEN STABILIZE.

<u>Approved</u>	9/03/2008 <small>Date</small>	 <b>SEDIMENT TRAPS</b>	<b>SC-7B</b>
<u>Revisions</u>			



## **SC-8 CURB AND GUTTER INLET PROTECTION**

A temporary sediment control barrier consisting of a filter media, such as compost filter socks, gravel and mesh, sandbags, gravel bags, etc., around a curb and gutter inlet designed to prevent sediment from entering the storm sewer. Shallow temporary ponding may occur during and after rainfall events.

### APPROPRIATE APPLICATIONS:

Place protection at inlets where runoff may contain sediment-laden water.

### CONDITIONS FOR EFFECTIVE USE:

Type of Flow: Sheet flow and concentrated flow.

Contributing Area: Maximum of 1 acre.

### WHEN BMP IS TO BE INSTALLED:

Install inlet protection immediately after installation of the inlet, or prior to land disturbing activities beginning on the contributing upstream area to the inlet.

### STANDARDS AND SPECIFICATIONS:

Typical types of curb and gutter inlet protection include: fabricated inlet filters (follow manufacturer's instructions), compost filter sock (make sure that both ends of the sock are anchored accordingly), gravel and wire mesh (construct and anchor wood frame, fasten wire mesh and fabric to frame and place the gravel on top of the entire structure), sandbags and gravel bags (may be placed either as a j-hook on the upstream end of the inlet or as a full barrier, sometimes stacked 2 bags high, across the entire opening of the inlet). Incorporate an overflow bypass into the inlet protection structure in areas, such as heavy traffic streets, where excessive ponding of water around the inlet may become a safety issue. Sediment controls behind the curb will be necessary to prevent the discharge of sediment in these bypasses.

### OPERATION AND MAINTENANCE PROCEDURES:

Inspect inlet protection of all media types weekly and after each ½" rainfall event to make sure they are functioning properly. Remove trash and debris. Remove sediment from the inlet protection when half of the protection structure height has been filled. Repair elements to original configuration as needed.

### SITE CONDITIONS FOR REMOVAL:

Remove after contributing drainage areas have been adequately stabilized.

### STANDARD DRAWING: SC-8

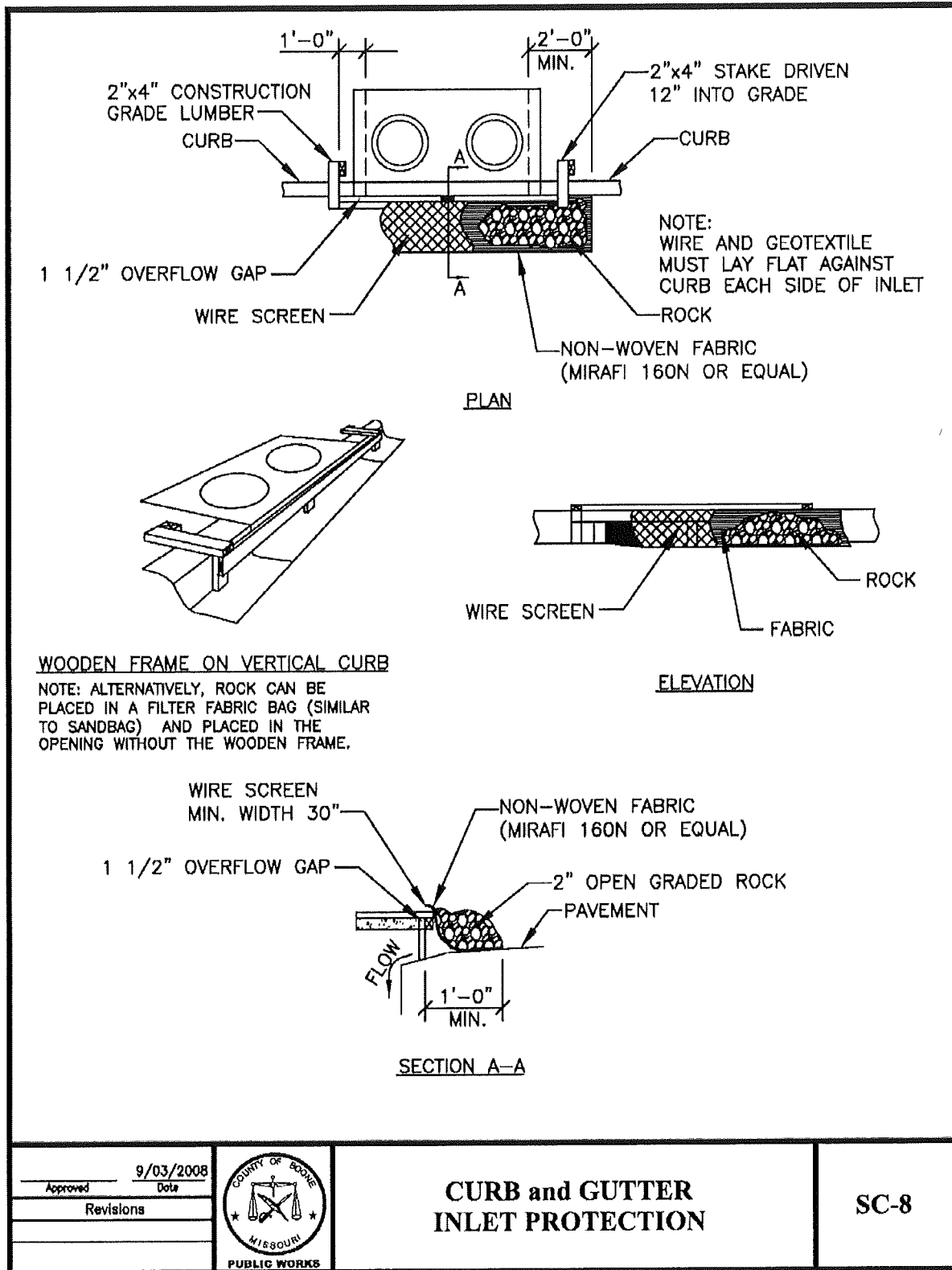



## **SC-9 DROP INLET PROTECTION**

A temporary sediment control barrier consisting of a filter fabric around a recessed area inlet designed to prevent sediment from entering the storm sewer. Shallow temporary ponding may occur during and after rainfall events.

### APPROPRIATE APPLICATIONS:

At recessed area or yard inlets where runoff may contain sediment-laden water.

### CONDITIONS FOR EFFECTIVE USE:

Type of Flow: Sheet flow and concentrated flow.

Contributing Area: Maximum of 1 acre.

### WHEN BMP IS TO BE INSTALLED:

Place inlet protection immediately after installation of the inlet, or prior to land disturbing activities beginning on the contributing upstream area to the inlet.

### STANDARDS AND SPECIFICATIONS:

Typical types of drop inlet protection include: manufactured filtering product or silt fence frames. Follow the manufacture's instruction for placement of proprietary products. For the silt fence protection, install a wood frame, dig a trench around the inlet for fabric to be buried, fasten fabric tightly to frame, backfill and compact trench. Alternatively, a sod filter can be installed by preparing and fertilizing the soil around the inlet and installing sod for a distance of at least 4 feet in each direction. The sod should be staked, stapled and/or netted at the corners and center of sod strips as required and then watered immediately. For safety, inlet protection structures which pond water onto streets, parking lots or driveways should be designed to have some method for allowing excess water from large storms to bypass or overflow.

### OPERATION AND MAINTENANCE PROCEDURES:

Inspect inlet protection of all media types weekly and after each significant rainfall event to make sure they are functioning properly. Remove trash and debris. Remove sediment from the inlet protection when half of the protection structure height has been filled. Repair elements to original configuration as needed.

### SITE CONDITIONS FOR REMOVAL:

Remove after contributing drainage areas have been adequately stabilized.

### STANDARD DRAWING: SC-9a and SC-9b

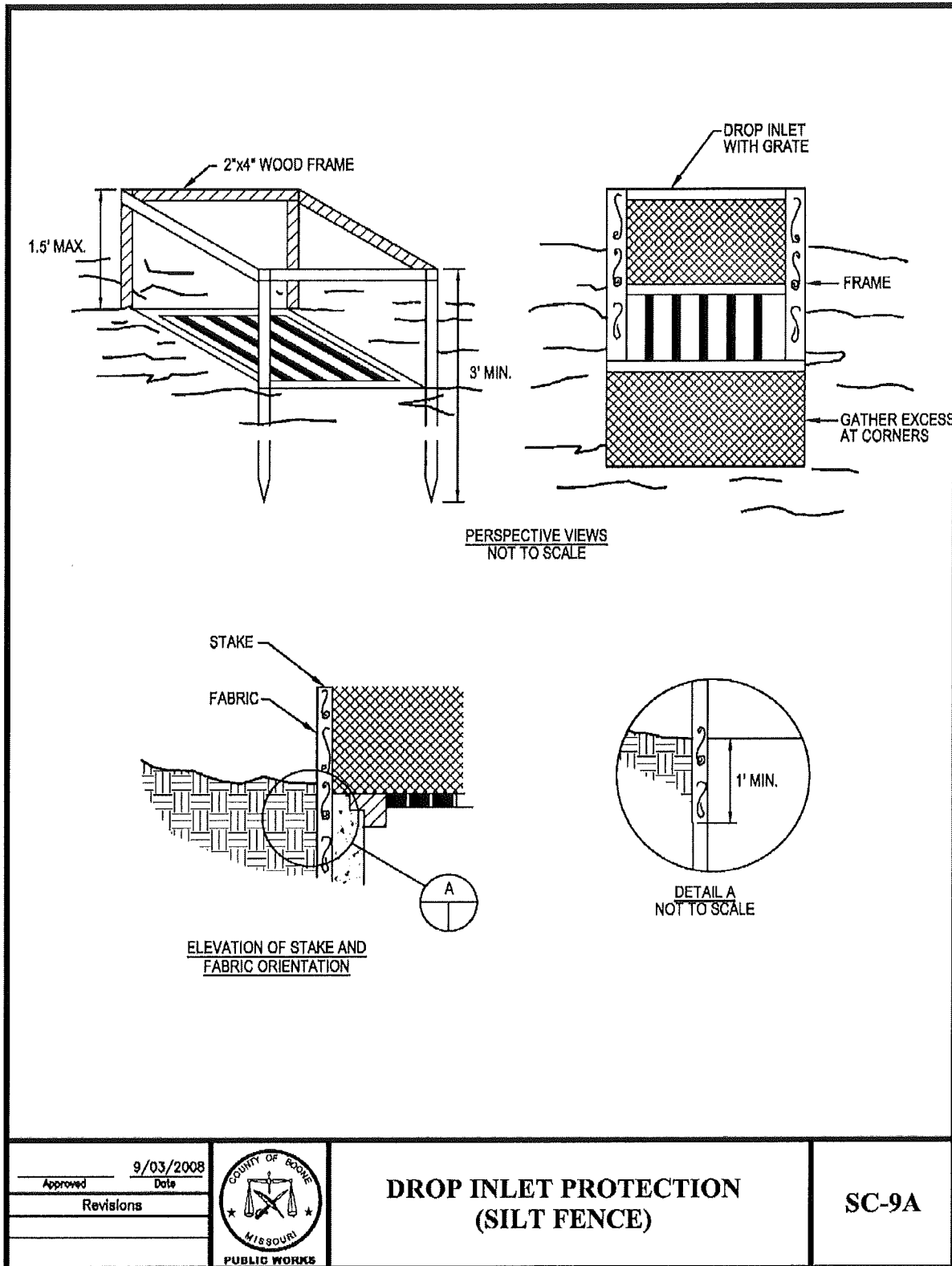



**SEDIMENT FENCE DROP INLET PROTECTION NOTES:**

**A) CONSTRUCTION SPECIFICATIONS:**

1. SEDIMENT FENCE SHALL BE CUT FROM A CONTINUOUS ROLL TO AVOID JOINTS.
2. FOR STAKES, USE 2X4 WOOD OR EQUIVALENT METAL WITH A MINIMUM LENGTH OF 3 FEET.
3. SPACE STAKES EVENLY AROUND THE PERIMETER OF THE INLET A MAXIMUM OF 3 FEET APART, AND SECURELY DRIVE THEM INTO THE GROUND, APPROXIMATELY 18 INCHES DEEP.
4. TO PROVIDE NEEDED STABILITY TO THE INSTALLATION, FRAME WITH 2X4 WOOD STRIPS AROUND THE CREST OF THE OVERFLOW AREA AT A MAXIMUM OF 1.5 FEET ABOVE THE DROP INLET CREST.
5. PLACE THE BOTTOM 12 INCHES OF THE FABRIC IN A TRENCH AND BACK FILL THE TRENCH WITH 12-INCHES OF COMPACTED SOIL.
6. FASTEN FABRIC SECURELY BY STAPLES, OR WIRE IT TO THE STAKES AND FRAME. JOINTS MUST BE OVERLAPPED TO THE NEXT STAKE.

**B) INSPECTION AND MAINTENANCE:**

1. THE STRUCTURE SHALL BE INSPECTED WEEKLY AND AFTER EACH RAIN EVENT OF 1/2 INCH OR GREATER AND REPAIRS MADE AS NEEDED.
2. SEDIMENT SHALL BE REMOVED AND THE TRAP RESTORED TO ITS ORIGINAL DIMENSIONS WHEN THE SEDIMENT HAS ACCUMULATED TO ONE HALF THE DESIGN DEPTH OF THE TRAP. REMOVED SEDIMENT SHALL BE DEPOSITED IN A SUITABLE AREA AND IN SUCH A MANNER THAT IT WILL NOT ERODE.
3. STRUCTURES SHALL BE REMOVED AND THE AREA STABILIZED WHEN THE REMAINING DRAINAGE AREA HAS BEEN PROPERLY STABILIZED.

_____ Approved	9/03/2008 Date	 <p><b>DROP INLET PROTECTION (SILT FENCE) NOTES</b></p>	<p><b>SC-9B</b></p>
_____ Revisions			
_____ _____			



## **TC-1 CONSTRUCTION ENTRANCE/EXIT**

A stabilized entrance to a construction site which is designed to minimize the amount of sediment tracked from the site on vehicles and equipment. Mud and sediment fall off of tires as they travel along the stabilized entrance.

### APPROPRIATE APPLICATIONS:

At locations where it is safe for construction vehicles and equipment to access existing streets, preferably at the location of future streets or drives.

### CONDITIONS FOR EFFECTIVE USE:

Site conditions will dictate design and need. Ditches or pipes, if needed, sized for 15 year, 20 minute storm; HGL 6" below surface of entrance.

### WHEN BMP IS TO BE INSTALLED:

Install stabilized construction entrance/exit prior to vehicles or equipment accessing unpaved areas. This will most likely be the first BMP to be installed on the site.

### STANDARDS AND SPECIFICATIONS:

Limit the points of entrance/exit to the construction site. Properly grade and compact each construction entrance/exit to prevent runoff from leaving the site. Install culvert under entrance if needed to maintain positive drainage. Place fabric and cover with aggregate, forming a diversion across the entrance, if needed, to direct runoff away from the roadway. Require all employees, subcontractors, and suppliers to utilize the stabilized construction access.

### OPERATION AND MAINTENANCE PROCEDURES:

Inspect routinely for damage and assess effectiveness of the BMP. Remove sediment and clods of dirt from construction entrance continuously. Replace rock, as necessary, to maintain a clean surface for traffic. Repair any areas that have settled. Keep all temporary roadway ditches clear. Immediately remove any mud or debris tracked onto paved surfaces.

### SITE CONDITIONS FOR REMOVAL:

Remove when vehicles and equipment will no longer require access to unpaved areas.

### STANDARD DRAWING: TC-1

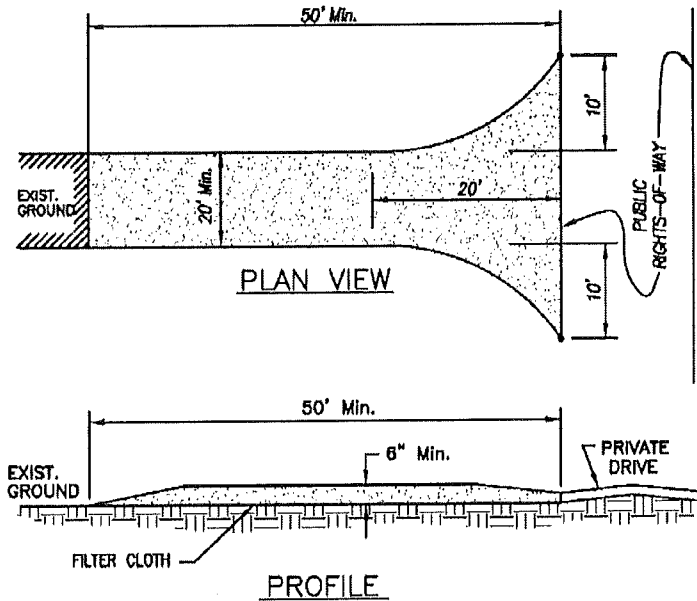

**CONSTRUCTION SPECIFICATIONS**

1. STONE SIZE - USE 2" STONE.
2. LENGTH - AS REQUIRED, BUT NOT LESS THAN 50 FEET.
3. THICKNESS - NOT LESS THAN SIX (6) INCHES.
4. WIDTH - TWENTY (20) FOOT MINIMUM, BUT NOT LESS THAN THE FULL WIDTH AT POINTS WHERE INGRESS OR EGRESS OCCURS.
5. FILTER CLOTH - WILL BE PLACED OVER THE ENTIRE AREA PRIOR TO PLACING OF STONE.
6. SURFACE WATER - ALL SURFACE WATER FLOWING OR DIVERTED TOWARD CONSTRUCTION ENTRANCES SHALL BE PIPED ACROSS THE ENTRANCE. IF PIPING IS IMPRACTICAL, A MOUNTABLE BERM WITH 3:1 SLOPES WILL BE PERMITTED.
7. MAINTENANCE - THE ENTRANCE SHALL BE MAINTAINED IN A CONDITION WHICH WILL PREVENT TRACKING OR FLOWING OF SEDIMENT ONTO PUBLIC RIGHTS-OF-WAY. THIS MAY REQUIRE PERIODIC TOP DRESSING WITH ADDITIONAL STONE AS CONDITIONS DEMAND AND REPAIR AND/OR CLEANOUT OF ANY MEASURES USED TO TRAP SEDIMENT. ALL SEDIMENT SPILLED, DROPPED, WASHED OR TRACKED ONTO PUBLIC RIGHTS-OF-WAY MUST BE REMOVED IMMEDIATELY.
8. PERIODIC INSPECTION AS NEEDED MAINTENANCE SHALL BE PROVIDED WEEKLY AND AFTER EACH RAIN EVENT GREATER THAN 1/2".

<p>Approved _____ 9/03/2008 Date</p> <p>Revisions _____</p>		<p><b>CONSTRUCTION ENTRANCE/EXIT</b></p>	<p><b>TC-1</b></p>
---	--	--	--------------------



## **TC-2 WASHDOWN STATION**

An area located at stabilized construction access points to remove sediment from tires and undercarriages, and to prevent sediment from being transported onto public roadways.

### APPROPRIATE APPLICATIONS:

Tire washes may be used on construction sites where dirt and mud tracking onto public roads by construction vehicles may occur.

### CONDITIONS FOR EFFECTIVE USE:

A downstream sediment trapping BMP is needed to treat dirty runoff from the washdown station. These stations require a supply of wash water and a turnout or doublewide exit to avoid having entering vehicles drive through the wash area.

### WHEN BMP IS TO BE INSTALLED:

Washdown stations should be installed along with the stabilized construction entrance/exit, prior to vehicles or equipment accessing unpaved areas.

### STANDARDS AND SPECIFICATIONS:

Grade and compact area for drainage under washdown pad. Install wash rack, which should be designed and constructed/manufactured for anticipated traffic loads. Provide a drainage ditch, grade that will convey the runoff from the wash area to a sediment trapping device. The drainage ditch should be of sufficient grade, width, and depth to carry the wash runoff. Install water supply and hose. Post signs in advance of the station indicating that all muddy vehicles and equipment must use the station prior to exiting the site.

### OPERATION AND MAINTENANCE PROCEDURES:

Remove accumulated sediment in wash rack and/or sediment trap on a daily basis or as needed to maintain system performance. Repair any areas that have settled. Replace rock if necessary to maintain a clean surface.

### SITE CONDITIONS FOR REMOVAL:

Remove when vehicles and equipment will no longer access unpaved areas.

### STANDARD DRAWING: TC-2

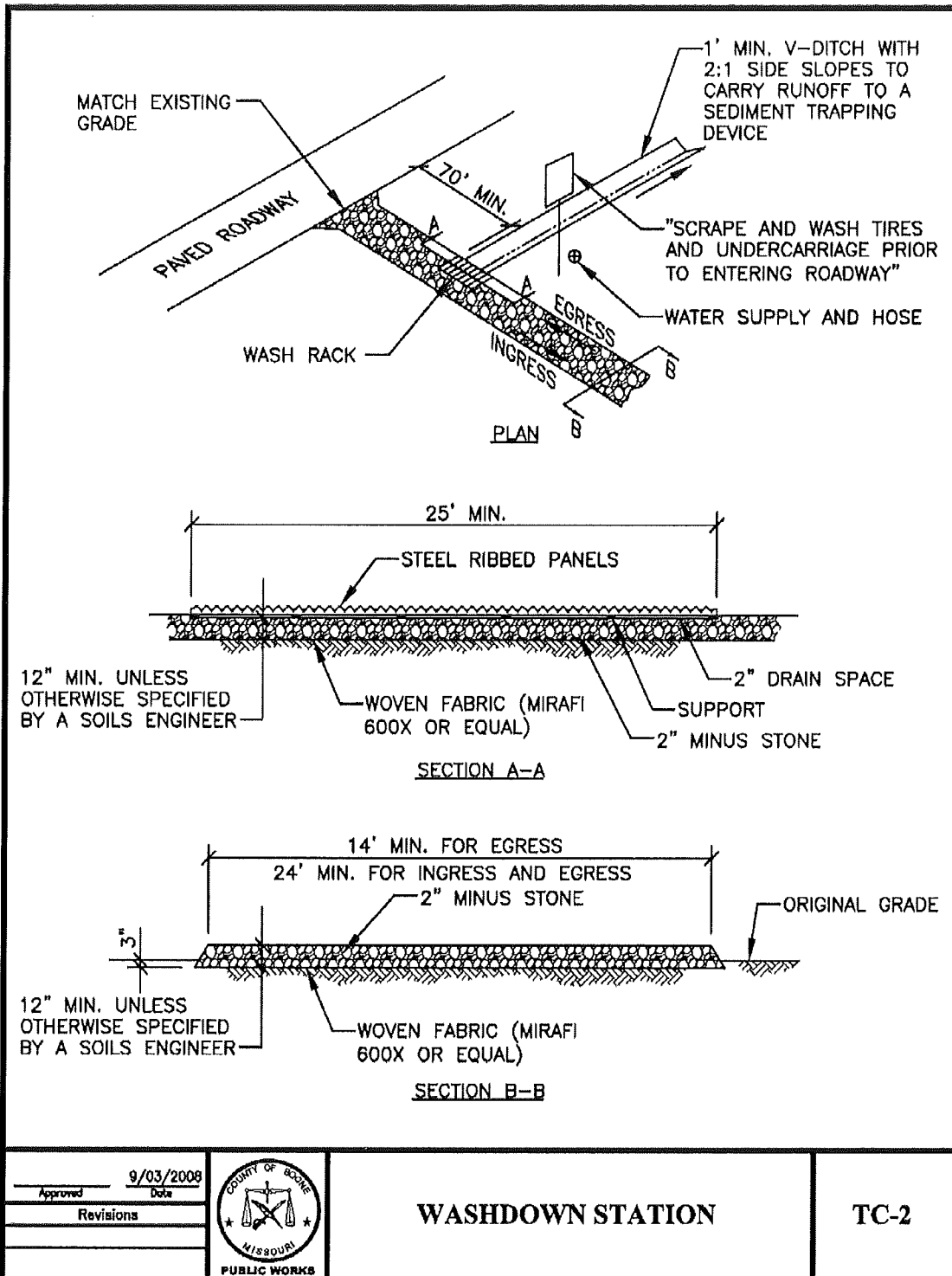



## **PP-1 NON-SEDIMENT POLLUTION CONTROL**

These control measures are designed to prohibit chemicals, hazardous materials, solid waste, human waste and construction debris from polluting stormwater. Pollutants carried in solution or as surface films on runoff will be carried through most erosion control and sediment capture BMPs. Keeping substances like fuel, oil, asphalt, paint, solvents, fertilizer, soil additives, concrete wash water, solid waste, human waste and construction debris from polluting runoff can be accomplished to a large extent through good housekeeping on the site and following the manufacturer's recommendations for disposal.

### APPROPRIATE APPLICATIONS:

Temporary sanitary facilities, collection, storage and fueling areas should be located onsite in an area that does not receive a substantial amount of runoff from upland areas and does not drain directly to lakes, creeks, streams, rivers, sewers, groundwater, wetlands, or road ditches.

### CONDITIONS FOR EFFECTIVE USE:

An effective management system requires training and signage to promote proper storage, handling and disposal of materials, and follow up observations of actions and inspection of storage areas by management. Plans should contain notes clearly stating requirements for addressing potential pollutants.

### WHEN BMP IS TO BE INSTALLED:

Pollution control practices should begin immediately and continue throughout the project.

### STANDARDS AND SPECIFICATIONS:

Place waste receptacles near area of work. All fueling facilities present on the site shall adhere to applicable federal and state regulations concerning underground storage, above ground storage, and dispensers. Hazardous wastes shall be managed according to Missouri Hazardous Waste Laws and Regulations. Install appropriate signage. Post guidelines for proper handling, storage and disposal of materials, and emergency spill cleanup on site. Provide sufficient temporary toilet facilities to serve the number of workers on the site.

### OPERATION AND MAINTENANCE PROCEDURES:

Inspect activities on a regular basis. Inspect storage areas and control devices at least every week and after every storm. Maintenance of temporary toilet facilities should be frequent and thorough. Make necessary corrections and repairs.

### SITE CONDITIONS FOR REMOVAL:

Remove after contributing drainage areas have been adequately stabilized.

### STANDARD NOTES:

General pollution notes:



1. Handling and disposal of hazardous materials:

DO: Prevent spills  
Use up products completely  
Follow label directions for disposal  
Remove lids from empty bottles and cans when disposing in trash  
Recycle wastes whenever possible

DON'T: Don't pour waste into sewers or waterways on the ground  
Don't pour waste down the sink, floor drain or septic tanks  
Don't bury chemicals or containers, or dispose of them with other waste  
Don't burn chemicals or containers  
Don't mix chemicals together

2. Containers shall be provided for collection of all waste material including construction debris, trash, petroleum products and any hazardous materials to be used onsite. All waste material shall be disposed of at facilities approved for that material.

3. No waste materials shall be buried on-site.

4. Mixing, pumping, transferring or otherwise handling construction chemicals such as fertilizer, lime, asphalt, concrete drying compounds, and all other potentially hazardous materials shall be performed in an area away from any watercourse, ditch or storm drain.

5. Equipment fueling and maintenance, oil changing, etc., shall be performed only in an area designated for that purpose. The designated area is equipped for recycling oil and catching spills.

6. Concrete wash water shall not be allowed to flow directly to storm sewers, streams, ditches, lakes, etc without being treated. A sump or pit shall be constructed to contain concrete wash water.

7. All paint, solvents, petroleum products and petroleum waste products, and storage containers (such as drums, cans, or cartons) shall be stored according to BMPs. The materials exposed to precipitation shall be stored in watertight, structurally sound, closed containers. All containers shall be inspected for leaks or spillage during the once per week inspection of BMPs. If substances such as oil, diesel fuel, hydraulic fluid, antifreeze, etc. are spilled, leaked, or released onto soil, the soil shall be dug up and properly disposed of. Spills on pavement shall be absorbed with sawdust, kitty litter or product designed for that purpose and disposed of at a licensed sanitary landfill. Hazardous or industrial wastes such as most solvents, gasoline, oil-based paints, and cement curing compounds require special handling. These materials will be removed from the site and recycled or disposed of in accordance with MoDNR requirements.

8. State law requires the party responsible for a petroleum product spill in excess of 50 gallons to report the spill to MoDNR (537-634-2436) as soon as practical after discovery.



Federal law requires the responsible party to report any release of oil if it reaches or threatens a sewer, lake, creek, stream, river, groundwater, wetland, or area, like a road ditch, that drains into one of the above.

9. Sufficient temporary toilet facilities to serve the number of workers on the site shall be provided. The facilities shall be serviced frequently to maintain a sanitary condition.