

COLE COUNTY DEPARTMENT OF PUBLIC WORKS



LAKESWOOD SUBDIVISION STORMWATER
IMPROVEMENTS
Project No. 2022-201-1

BID DATE: January 13, 2023

BIDDING DOCUMENTS

TABLE OF CONTENTS

| | PAGE NO. |
|---|-----------------|
| SECTION 1 | |
| Advertisement for Bids | 1-1 |
| Notice to Bidders | 1-3 |
| SECTION 2 | |
| Instructions to Bidders | 2-1 |
| SECTION 3 | |
| Plan Holder Contact Information Form | 3-1 |
| Bid Proposal Form | 3-3 |
| Anti-Collusion Statement | 3-9 |
| Contractor's Affidavit | 3-11 |
| SECTION 4 | |
| Construction Contract | 4-1 |
| Certificate of Insurance | 4-7 |
| Performance and One-Year Guarantee Bond | 4-9 |
| SECTION 5 | |
| Current Prevailing Wage Rate | 5-1 |
| SECTION 6 | |
| Job Special Provisions | 6-1 |
| SECTION 7 | |
| General Special Provisions | 7-1 |
| SECTION 8 | |
| Technical Specifications | 8-1 |
| SECTION 9 | |
| MoDNR Land Disturbance Permit | 9-1 |
| SECTION 10 | |
| Cole County Storm Water Pollution Prevention Plan (SWPPP) | 10-1 |
| SECTION 11 | |
| Plan Sheets | 11-1 |

ADVERTISEMENT FOR BIDS

NOTICE TO BIDDERS

SEALED PROPOSALS consisting of:

**LAKWOOD SUBDIVISION STORMWATER IMPROVEMENTS
PROJECT NO. 2022-201-1**

Located on Lakewood Road and Dawnwood Circle in Sec 22, T44N, R12W
in Cole County, Missouri, and

WILL be received and opened publicly at the office of Cole County Commission,
Courthouse Annex, Room 200, 311 East High Street, Jefferson City, Missouri 65101 at

9:00 A.M. on Friday, January 13, 2023

Any and all bids received after the time specified above will be returned unopened.

The proposed work consists of removals, clearing and grubbing, grading, excavating,
drainage structures, seeding and mulching, erosion control, and miscellaneous work on
Lakewood Road and Dawnwood Circle near Jefferson City.

Plans and specifications may be viewed and downloaded online in the bids section at
www.colecounty.org. A hard copy of the specifications will not be provided but an 11"x17"
hard copy of the plans will be provided upon request in advance.

All contractors wishing to bid on this project shall submit the plan holder contact
information form found in the specifications to ccpwprojects@colecounty.org prior to the
bid opening.

The Owner reserves the right to reject any and all bids and to waive informalities therein,
to determine the lowest and best bid and to approve the bond. E.O.E.

News Tribune: 12/18/22; 12/25/22 and 1/1/23

NOTICE TO BIDDERS

Sealed proposals will be received at the office of the Cole County Commission, Courthouse Annex, Room 200, 311 East High Street, Jefferson City, Missouri, 65101, until 9:00 A.M., **Friday, January 13, 2023**. The bids will be opened and read aloud at the Cole County Commission, Courthouse Annex, Room 200, 311 East High Street at 9:00 A.M. on that same day.

The proposed work consists of removals, clearing and grubbing, grading, excavating, drainage structures, seeding and mulching, erosion control, and miscellaneous work on Lakewood Road and Dawnwood Circle near Jefferson City for:

LAKWOOD SUBDIVISION STORMWATER IMPROVEMENTS PROJECT NO. 2022-201-1

All equipment, material, and workmanship must be in accordance with the plans, specifications, and contract documents on file with the Director of Cole County Public Works, 5055 Monticello Road, Jefferson City, Missouri 65109.

Plans and specifications may be viewed and downloaded online in the bids section at www.colecounty.org. A hard copy of the specifications will not be provided but a hard copy of the plans will be provided upon request in advance. All contractors wishing to bid on this project shall submit the plan holder contact information form found in the specifications to ccpwprojects@colecounty.org prior to the bid opening.

All wages paid for work under this contract shall comply with requirements of the prevailing wage law of the State of Missouri, Section 290.210 through 290.340, RSMo. 1986.

A certified check on a solvent bank or a bid bond by a satisfactory surety in an amount to five percent (5%) of the total amount of the bid must accompany each proposal.

A one-year Performance and Guarantee Bond is required.

The County reserves the right to reject any or all bids and to waive informalities therein to determine which is the lowest and best bid and to approve the bond.

COUNTY OF COLE



Mattheuw Prenger, P.E.
County Engineer

INSTRUCTIONS TO BIDDERS

2-1 Scope of Work

The proposed work consists of removals, clearing and grubbing, grading, excavating, drainage structures, seeding and mulching, erosion control, and miscellaneous work on Lakewood Road and Dawnwood Circle near Jefferson City.

2-2 Inspection of Plans, Specifications, and Site of Work

The bidder is required to examine carefully the site of the proposed work, the proposal, plans, specifications, supplemental specifications, special provisions, and contract forms before submitting a proposal.

2-3 Interpretation of Contract Documents

If the bidder has any questions which arise concerning the true meaning or intent of the Plans, Specifications, or any part thereof, which affect the cost, quality, quantity, or character of the project, he shall request in writing that an interpretation be made and an addendum be issued by the Engineer, which shall then be delivered to all bidders to whom Plans and Specifications have been issued. Failure to have requested an addendum covering any questions affecting the interpretations of the Plans and Specifications shall not relieve the Contractor from delivering the completed project in accordance with the intent of the Plans and Specifications to provide a workable project.

2-4 Qualifications of Bidders

The County of COLE may make such investigations as deemed necessary to determine the ability of the bidder to perform the work and the bidder shall furnish to the County of COLE all such information and data for this purpose as the County of COLE may request. The County of COLE reserves the right to reject any bid if the evidence submitted by the bidder or investigation of such bidder fails to satisfy the County of COLE that such bidder is properly qualified to carry out the obligations of the Contract and to complete the work contemplated therein.

2-5 Equivalent Material

Wherever definite reference is made in these Specifications to the use of any particular material or equipment, it is to be understood that any equivalent material or equipment may be used which will perform adequately the duties imposed by the general design, subject to the approval of the Engineer.

2-6 Bid Security

Each bid must be accompanied by a certified check or bid bond made payable to the County of COLE for five percent (5%) of the amount of the base bid. Bid securities will be returned after award of contract except to the successful bidder.

Should the successful bidder or bidders fail or refuse to execute the bond and the contract required within ten (10) days after he has received Notice of Acceptance of his bid, he shall forfeit to the County of COLE as liquidated damages for such failure or refusal, the security deposited with his bid.

2-7 Preparation of Bids

Bid must be made upon prescribed forms attached at the back of these Specifications. Only sealed bids will be considered, all bids otherwise submitted will be rejected as irregular.

Do NOT include federal excise tax or sales and use taxes in the bid prices. This project will be a **SALES TAX EXEMPT** project. A copy of the federal tax exemption certificate will be furnished if required.

All blank spaces in the bid must be filled in and no change shall be made in the phraseology of the bid or addition to the items mentioned therein. Any conditions, limitation, or provisions attached to bids will render them informal and may be considered cause for their rejection.

2-8 Prices

The price submitted for each item of the work shall include all cost of whatever nature involved in its construction, complete in place, as described in the Specifications.

2-9 Addenda

Addenda may be issued on this project at any time up to 24 hours prior to the bid date and time. Occasionally an addendum may contain information that could affect a contractor's bid. It shall be the responsibility of the contractor to verify if any addenda have been issued prior to submitting their bid. The County assumes no liability if a contractor fails to incorporate addenda into their bid.

2-10 Approximate Quantities

In cases where any part or all of the bidding is to be received on a unit price basis, the quantities stated in the bid will not be used in establishing final payment due the successful Contractor. The quantities stated on which unit prices are so invited are approximate only and each bidder shall make his own estimate from the plans of the quantities required on each item and calculate his unit price bid for each item accordingly. Bids will be compared on the basis of number of units stated in the bid. Such estimated quantities, while made from the best information available, are approximate only. Payment on the Contract will be based on actual number of units installed on the completed work.

2-11 Lump Sum Items

Payment for each lump sum item shall be at the lump sum bid for the item, complete in place, and shall include the costs of all labor, materials, tools, and equipment to construct the item as described herein and to the limits shown on the Plans.

2-12 Submission of Bids

The Bid and the Bid Security guaranteeing the same shall be placed in a sealed opaque envelope and marked **LAKEWOOD SUBDIVISION STORMWATER IMPROVEMENTS, PROJECT NO. 2022-201-1**. The envelope shall be clearly marked with the project name, project number, and the bidder's name and address.

2-13 Alternate Bids

In making the award if alternate bids have been requested, that alternate bid will be used which will be to the best interest of the County of COLE.

2-14 Withdrawal of Bids

If a bidder wishes to withdraw his bid, he may do so before the time fixed for the opening, without prejudice to himself. No bidder may withdraw his bid for a period of ninety (90) days after the scheduled closing time for the receipt of bids.

2-15 Right to Reject Bids

The County of COLE reserves the right to reject any or all bids, to waive any informality in the bids received, or to accept the bid or bids that in its judgment will be for the best interest of the County of COLE.

2-16 Award of Contract

If within ten (10) days after he has received Notice of Acceptance of his bid, the successful bidder or bidders shall refuse or neglect to come to the office of the Director of Public Works and to execute the Contract and to furnish the required Contractor's Bond, properly signed by the Contractor and the Surety or Sureties satisfactory to the County of COLE as hereinafter provided, the bidder or bidders shall be deemed to be in default and shall forfeit the deposit.

2-17 Performance, Payment and One Year Guarantee Bond

A Performance, Payment and One Year Guarantee Bond in an amount equivalent to one hundred percent (100%) of the Contract price, must be furnished and executed by the successful bidder or bidders, this bond to be in the form contained in this Contract.

The Surety shall be a corporate Surety Company or companies of recognized standing licensed to do business in the State of Missouri and acceptable to the County of COLE.

2-18 Indemnification and Insurance

The Contractor agrees to indemnify and hold harmless the County and the Engineer from all claims and suits for loss of or damage to property, including loss of all judgments recovered therefore, and from all expense in defending said claims, or suits, including court costs, attorney fees, and other expense caused by any act or omission of the Contractor and/or his subcontractors, their respective agents, servants, or employees.

Certificate of Insurance

The Contractor shall be required to provide the County of COLE with a "Certificate of Insurance."

2-19 Bid Security Returned to Successful Bidder

Upon the execution of the Contract and approval of Bond, the Bid Security will be returned to the bidder unless the same shall have been presented for collection prior to such time, in which case the amount of the deposit will be refunded by the County of COLE.

2-20 Nondiscrimination in Employment

Contracts for work under this bid will obligate the Contractor and subcontractors not to discriminate in employment practices.

2-21 Prevailing Wage Law

The principal contractor and all subcontractors shall pay not less than the prevailing wage hourly rate for each craft or type of workman required to execute this contract as determined by the Department of Labor and Industrial Relations of Missouri, pursuant to Sections 290.210 through 290.340, RSMo. 1986. (See Determination herewith included in Section 5.)

2-22 Guarantee

The Contractor guarantees that the equipment, materials, and workmanship furnished under this contract will be as specified and will be free from defects for a period of one (1) year from the date of final acceptance. In addition, the equipment furnished by the Contractor shall be guaranteed to be free from defects in design.

Within the guarantee period and upon notification of the Contractor by the County, the Contractor shall promptly make all needed adjustments, repairs, or replacements arising out of defects which, in the judgment of the Engineer, or the County, become necessary during such period.

The cost of all materials, parts, labor, transportation, supervision, special tools, and supplies required for replacement of parts, repair of parts, or correction of abnormalities shall be paid by the Contractor, or by his surety under the terms of the Bond.

The Contractor also extends the terms of this guarantee to cover repaired parts and all replacement parts furnished under the guarantee provisions for a period of one (1) year from the date of installation thereof.

If within ten (10) days after the County gives the Contractor notice of a defect, failure, or abnormality of the work, the Contractor neglects to make, or undertake with due diligence to make, the necessary repairs or adjustments themselves or order the work to be done by a third party, the costs of the work shall be paid by the Contractor.

In the event of an emergency where, in the judgment of the County, delays would cause serious loss or damage, repairs or adjustments may be made by the County, or a third party chosen by the County, without giving notice to the Contractor, and the cost of the work shall be paid by the Contractor, or by his surety under the terms of the Bond.

2-23 Notice to Proceed

A written notice to begin construction work will be given to the Contractor by the County of COLE after the Contractor has executed the Contract Documents. No direct payment will be made to the Contractor for any reason of their compliance with this provision. The Contractor shall have no claim, or basis for any claim or suit whatsoever, resulting from this notice to proceed.

2-24 Work Schedule

To insure that the work will proceed continuously through the succeeding operations to its completion with the least possible interference to traffic and inconvenience to the public, the Contractor shall submit for approval a complete schedule of his proposed construction procedure, stating the sequence in which various operations of work are to be performed. The Contractor may not change the work sequence without the prior approval of the Engineer. Additional detailed information can be found in the job special provisions.

2-25 Section 292.675 RSMo. Safety Training Requirements

In 2008 the Missouri General Assembly adopted HB 1549, creating additional requirements affecting public works contracts by requiring all contractors and subcontractors doing work on a project to provide and require their on-site employees to complete a ten (10) hour course in construction safety and health that is approved by the federal Occupational Safety and Health Administration ("OSHA") or a similar program approved by the Missouri Department of Labor and Industrial Relations, which is at least as stringent as an approved OSHA program; and

The following items will be required in this contract:

Section One: Any contractor for Cole County for purposes of construction of public works and any subcontractor to such contractor shall comply with the provisions of section 292.675, RSMo. and provide a ten-hour OSHA construction safety program for the on-site employees which includes a course in construction safety and health approved by OSHA or a similar program approved by the Missouri Department of Labor and Industrial Relations that is at least as stringent as an approved OSHA program, unless such employees have previously completed the required program.

Section Two: All employees who have not previously completed this course must do so within sixty (60) days of beginning work on a Cole County construction project.

Section Three: Any employee found on a work site subject to this ordinance without documentation of successfully completing this course shall have twenty (20) days to produce such documentation before being subject to removal from the project.

2-26 Excessive Unemployment Law and Restrictive States

Bidders are hereby notified that the excessive unemployment law is in effect. During times of high unemployment, state law permits the Department's Division of Labor Standards to declare that excessive unemployment is in effect, allowing only workers from certain states to work on the Missouri's public works projects. Public works projects are construction projects funded wholly or partially from public funds, or are projects that benefit the public such as but not limited to schools, parks, fire houses, and government buildings. The excessive unemployment law does not apply to projects funded in part by Federal Funds.

Restrictive states have laws in place restricting Missouri workers to work on their public works projects. Workers from these states are also not allowed to work on Missouri's public works projects.

Only Missouri laborers and laborers from nonrestrictive states are allowed by law to be employed on Missouri's public works projects when the unemployment rate exceeds **5 percent** for two consecutive months. **(See Sections 290.550 through 290.580 RSMo).**

Restrictive States - workers from these states are **NOT** allowed to be employed on Missouri public works projects: Alaska, Arizona, California, Colorado, Connecticut, Delaware, District of Columbia, Florida, Idaho, Illinois, Iowa, Maine, Massachusetts, Mississippi, Montana, Nevada, New Jersey, North Dakota, South Dakota, and the U.S. Virgin Islands, West Virginia and Wyoming.

Non-Restrictive States - workers from these states are allowed to be employed on Missouri public works projects: Alabama, Arkansas, Georgia, Hawaii, Indiana, Kansas, Kentucky, Louisiana, Maryland, Michigan, Minnesota, Nebraska, New Hampshire, New Mexico, New York, North Carolina, Ohio, Oklahoma, Oregon, Pennsylvania, Rhode

Island, South Carolina, Tennessee, Texas, Utah, Vermont, Virginia, Washington and Wisconsin.

2-27 Contract Time

This contract shall be a completion date contract. The contract shall be completed by no later than **May 19, 2023**. Additional information pertaining to the completion date can be found in the Job Special Provisions.

2-28 Liquidated Damages

Liquidated damages shall be assessed at the rate of **Seven Hundred Dollars (\$700.00)** per calendar day until the project is complete, should the project not be completed with the specified time period.

All information pertaining to the liquidated damages can be found in the Job Special Provisions.

2-29 Pre-Construction Meeting

A pre-construction meeting will be scheduled before construction begins. The contractor's project manager, work zone manager and foreman shall be required to attend.

PLAN HOLDER CONTACT INFORMATION

COUNTY OF COLE, MISSOURI

**LAKWOOD SUBDIVISION STORMWATER IMPROVEMENTS
PROJECT NO. 2022-201-1**

All potential bidders **SHALL** complete this form and submit it to the Cole County Public Works email address listed below in order to provide contact information required. All other plan holders may submit this form at their own option. Addenda will be posted on the county website. In the event of disruption of website services, all such information will be communicated to all registered plan holders.

Any bids received from individuals/companies that do not submit this form in advance will not be opened.

Project Name: Lakewood Subdivision Stormwater Improvements
Project No. 2022-201-1
Bid Opening Date/Time: January 13, 2023
Plans and Specifications: Free Download Below

<https://colecouny.org/Bids.aspx?CatID=29&txtSort=Category&showAllBids=on&Status>

Contact Information: (All Information is Required)

Company Name (If Applicable): _____

Plan Holder Name / Contact: _____

Address: _____

City, State, Zip Code: _____

Phone: _____

Email: _____

Email this completed form to: ccpwprojects@colecouny.org

PROPOSAL FORM

COUNTY OF COLE, MISSOURI

**LAKWOOD SUBDIVISION STORMWATER IMPROVEMENTS
PROJECT NO. 2022-201-1**

Name of Bidder: _____

Address of Bidder: _____

To: Cole County Department of Public Works
5055 Monticello Road
Jefferson City, MO 65109

THE UNDERSIGNED BIDDER, having examined the Plans, Specifications, Regulations of the Contract, Special Conditions and other proposed Contract Documents, and all addenda thereto; and being acquainted with and fully understanding (a) the extent and character of the work covered by this Proposal; (b) the location, arrangement, and specified requirements for the proposed work; (c) the location, character, and condition of existing streets, roads, highways, railroads, pavement, surfacing, walks, driveways, curbs, gutters, trees, sewers, utilities, drainage courses and structures, and other installation, both surface and underground which may affect or be affected by the proposed work; (d) the nature and extent of the excavations to be made, and the type, character, and general condition of materials to be excavated; (e) the necessary handling and re-handling of excavated materials; (f) the location and extent of necessary or probable dewatering requirements; (g) storm and flood water; (h) local conditions relative to labor, transportation, hauling, and rail delivery facilities; and (i) all other factors and conditions affecting or which may be affected by the work.

HEREBY PROPOSED to furnish all required materials, supplies, equipment, tools, and plant; to perform all necessary labor and supervision; and to construct, install, erect, and complete all work stipulated in, required by, and in accordance with the proposed Contract Documents and the drawings, Specifications, and other documents referred to therein (as altered, amended, or modified by addenda), in the manner and time prescribed and that he will accept in full payment sums determined by applying to the quantities of the following items, the following unit prices and/or any lump sum payments provided, plus or minus any special payments and adjustments provided in the Specifications and he understands that the estimated quantities herein given are not guaranteed to be the exact or total quantities required for the completion of the work shown on the drawings and described in the Specifications, and that increases or decreases may be made over or under the Contract estimated quantities to provide for needs that are determined during progress of the work and that prices bid shall apply to such increased or decreased quantities as follows:

**LAKWOOD SUBDIVISION STORMWATER IMPROVEMENTS
PROJECT NO. 2022-201-1**

| BID PROPOSAL FORM | | | | | |
|--------------------------|-------------------------------------|-------|--------------|------------|--------|
| ITEM | DESCRIPTION | UNITS | NO. OF UNITS | UNIT PRICE | AMOUNT |
| 1 | MOBILIZATION | LS | 1 | | |
| 2 | REMOVAL OF IMPROVEMENTS | LS | 1 | | |
| 3 | EARTHWORK | LS | 1 | | |
| 4 | 15" HDPP STORMWATER PIPE | LF | 16 | | |
| 5 | 24" HDPP STORMWATER PIPE | LF | 95 | | |
| 6 | 30" HDPP STORMWATER PIPE | LF | 81 | | |
| 7 | 24" FES (GALVANIZED) | EA | 1 | | |
| 8 | 30" FES (GALVANIZED) | EA | 2 | | |
| 9 | 8' X 3' TYPE A INLET (I-1) | EA | 1 | | |
| 10 | 4' X 3' TYPE A INLET (I-2) | EA | 1 | | |
| 11 | 8' X 3' TYPE A INLET (I-3) | EA | 1 | | |
| 12 | 4' X 3' TYPE A INLET (I-4) | EA | 1 | | |
| 13 | SADDLE T PIPE CONNECTION | EA | 1 | | |
| 14 | 8" NON-REINFORCED CONCRETE PAVEMENT | SY | 115 | | |
| 15 | SEGMENTAL BLOCK RETAINING WALL | SF | 200 | | |
| 16 | TYPE 2 ROCK DITCH LINER | CY | 10 | | |
| 17 | LAWN RESTORATION | LS | 1 | | |
| 18 | EROSION CONTROL | LS | 1 | | |
| TOTAL BID | | | | | |

BIDDER recognizes and acknowledges the receipt of the following Addenda:

| <u>DATE</u> | <u>Addendum Number</u> | <u>DATE</u> | <u>Addendum Number</u> |
|-------------|------------------------|-------------|------------------------|
|-------------|------------------------|-------------|------------------------|

If the Bidder intends to use any subcontractor in the course of the construction, he shall list them. (If necessary, attach additional pages to list all subcontractors.)

| <u>Company Name</u> | <u>Address</u> | <u>City, State, Zip</u> | <u>Work To Be Performed</u> | <u>% of Bid</u> |
|---------------------|----------------|-------------------------|-----------------------------|-----------------|
|---------------------|----------------|-------------------------|-----------------------------|-----------------|

TIME OF COMPLETION:

The undersigned hereby agrees to complete the project by no later than **May 19, 2023**, subject to the stipulations of the regulations of the Contract and the Special Conditions.

It is understood that the specifications governing the construction of the work contemplated are those known and designated as the "Missouri Highway & Transportation Commission Standard Specifications for Highway Construction" approved by the Missouri Highways & Transportation Commission, together with the special provisions, job and general, if any attached to this proposal.

It is understood and agreed that if this Proposal is accepted, the prices quoted above include all applicable state taxes and that said taxes shall be paid by the Contractor.

The undersigned, as Bidder, hereby declares that the only persons or firms interested in the Proposal as principal or principals is or are named herein and that no other persons or firms than herein mentioned have any interest in this Proposal or in the Contract to be entered into; and this Proposal is made without connection with any other person, company, or parties making a bid or proposal; and that it is in all respects fair and in good faith, without collusion or fraud.

The undersigned agrees that the accompanying bid deposit shall become the property of the County should he fail or refuse to execute the Contract or furnish Bond as called for in the specifications within the time provided.

If written notice of the acceptance of this bid is mailed, telegraphed, or delivered to the undersigned within ninety (90) days after the date of opening of bids, or any time thereafter before this bid is withdrawn, the undersigned will, within ten (10) days after the

date of such mailing, telegraphing, or delivering of such notice, execute and deliver a Contract in the form of Contract attached.

The undersigned hereby designates as his office to which such notice of acceptance may be mailed, telegraphed, or delivered:

| Contact Person | Company Name | Mailing Address | City, State & Zip Code |
|----------------|--------------|-----------------|------------------------|
|----------------|--------------|-----------------|------------------------|

It is understood and agreed that this bid may be withdrawn at any time prior to the scheduled time for the opening of bids or any authorized postponement thereof.

Attached hereto is a Bid Bond for the sum of _____

_____ (\$ _____)

Dollars (cashier's check), made payable to the County of COLE.

SIGNATURE AND IDENTITY OF BIDDER

The undersigned states that the correct LEGAL NAME and ADDRESS of (1) the individual bidder, (2) each partner or joint venturer (whether individuals or corporation, and whether doing business under a fictitious name), or (3) the corporation (with the state in which it is incorporated) are shown below; and that (if not signing with the intention of binding himself to become the responsible and sole contractor) he is the agent of, and duly authorized in writing to sign for the Bidder or Bidders; and that he is signing and executing this (as indicated in the proper spaces below) as the proposal of

AN INDIVIDUAL:

Name of Individual

Residence Street Address

Social Security Number

City, State & Zip Code

Firm Name, If Any

Business Address

Business Telephone Number

City, State & Zip Code

Signature

Date

A PARTNERSHIP:

Name of Partnership

(State Names & Addresses of All Partners)

Partner

Residence Address

Partner

Residence Address

Business Address

City, State & Zip Code

Business Telephone Number

Signature of At Least One Partner

Date

A CORPORATION:

Name of Corporation

Incorporated under the laws of the State
of _____

Name and Title of Officer

Corporate License No. _____
(If a corporation organized in state other
than Missouri, attach Certificate of _____
Authority to do business in the State of
Missouri.)

Business Telephone Number

Business Address

City, State & Zip Code

Signature of Officer

Date

ATTEST:

Signature of Secretary (SEAL)

Date

CONSTRUCTION CONTRACT

THIS CONTRACT, made and entered into this _____ day of _____, 2023, by and between **[INSERT CONTRACTOR'S NAME]**, hereinafter called "Contractor," and the **County of Cole, Missouri**, hereinafter called "County."

WITNESSETH: That Whereas, the Contractor has become the lowest responsible bidder for furnishing the supervision, labor, tools, equipment, materials, and supplies and for constructing the following County improvements:

**LAKWOOD SUBDIVISION STORMWATER IMPROVEMENTS
PROJECT NO. 2022-201-1**

NOW, THEREFORE, the parties to this contract agree to the following:

1. **Manner and Time for Completion** The Contractor agrees with the County to furnish all supervision, labor, tools, equipment, materials, and supplies; to perform all necessary labor and supervision; and to construct, install, erect and complete all work stipulated in, required by and in accordance with the contract documents and drawings, specifications and other documents referred therein (as altered, amended or modified by addenda) and with any applicable County regulations and state and federal laws, within ten (10) working days from the date Contractor is ordered to proceed, which order shall be issued by the Director of Public Works in accordance with the contract documents.

2. **Prevailing Wages** All labor utilized in the construction of the aforementioned improvements shall be paid a wage of no less than the "prevailing hourly rate of wages" for work of a similar character in this locality, as established by the Department of Labor and Industrial Relations of the State of Missouri. Contractor acknowledges that Contractor knows the prevailing hourly rate of wages for this project because Contractor has obtained the prevailing hourly rate of wages from the contents of **ANNUAL WAGE ORDER NUMBER 29 - COLE COUNTY** in which the rate of wages is set forth. The Contractor further agrees that Contractor will keep an accurate record showing the names and occupations of all workmen employed by Contractor in connection with the work to be performed under the terms of this contract. The record shall show the actual wages paid to the workmen in connection with the work to be performed under the terms of this contract. A copy of the record shall be delivered to the Director of Public Works each week. In accordance with Section 290.250 RSMo., Contractor shall forfeit to the County One Hundred Dollars (\$100.00) for each workman employed, for each calendar day or portion thereof that the workman is paid less than the stipulated rates for any work done under this contract, by the Contractor or any subcontractor under the Contractor.

3. **Contract Sum** The County shall pay the Contractor for the prompt, faithful, and efficient performance of the conditions and undertakings of this contract, subject to additions, and deductions as provided, herein, in current funds the sum of **[Insert Construction Amount]**.

TOTAL CONTRACT AMOUNT.....\$0,000,000

The County hereby accepts and reserves and the Contractor is hereby bound thereby, Unit Prices of the Proposal submitted as follows:

UNIT PRICES:

For changing specified quantities of work from those indicated by the plans and specifications, upon written instructions of the County, the following unit prices shall prevail. The unit prices include all labor, overhead and profit, materials, equipment, appliances, bailing, shoring, shoring removal, etc., to cover the finished work of the several kinds called for. Only a single unit price shall be given and it shall apply for either MORE or LESS work than shown on the plans and called for in the specifications. In the event of more or less units than so indicated or included, change orders shall be issued for the increased or decreased amount.

Itemized Quantities shall be placed here in awarded contract

4. Insurance Contractor shall procure and maintain at its own expense during the life of this contract:

(a) **Workers Compensation Insurance** for all of its employees to be engaged in work under this contract.

(b) **Contractor's Public Liability Insurance** in an amount not less than \$1,000,000 for all claims arising out of a single occurrence and \$100,000 for any one person in a single accident or occurrence, except for those claims governed by the provisions of the Missouri workers compensation law, Chapter 287, RSMo., and Contractor's Property Damage Insurance in an amount not less than \$800,000 for all claims arising out of a single accident or occurrence and \$100,000 for any one person in a single accident or occurrence.

(c) **Automobile Liability Insurance** in an amount not less than \$1,000,000 for all claims arising out of a single accident or occurrence and \$100,000 for any one person in a single accident or occurrence.

(d) **Owner's Protective Liability Insurance** The Contractor shall also obtain at its own expense and deliver to the County a Owner's Protective Liability Insurance Policy

naming the County of Cole as the insured, in an amount not less than \$1,000,000 for all claims arising out of a single accident or occurrence and \$100,000 for any one person in a single accident or occurrence, except for those claims governed by the provisions of the Missouri workmen's compensation law, Chapter 387, RSMo. No policy will be accepted which excludes liability for damage to underground structures or by reason of blasting, explosion, or collapse.

(e) Subcontracts In case any or all of this work is sublet, the Contractor shall require the Subcontractor to procure and maintain all insurance required in Subparagraphs (a), (b), and (c) hereof and in like amounts.

(f) Scope of Insurance and Special Hazard The insurance required under Subparagraphs (b) and (c) hereof shall provide adequate protection for the Contractor and its subcontractors, respectively, against damage claims which may arise from operations under this contract, whether such operations be by the insured or by anyone directly or indirectly employed by it, and also against any special hazards which may be encountered in the performance of this contract.

NOTE: Paragraph (f) is construed to require the procurement of Contractor's protective insurance (or contingent public liability and contingent property damage policies) by a general contractor whose subcontractor has employees working on the project, unless the general public liability and property damage policy (or rider attached thereto) of the general contractor provides adequate protection against claims arising from operations by anyone directly or indirectly employed by the Contractor.

5. Contractor's Responsibility for Subcontractors It is further agreed that Contractor shall be as fully responsible to the County for the acts and omissions of its subcontractors, and of persons either directly or indirectly employed by them, as Contractor is for the acts and omissions of persons it directly employs. Contractor shall cause appropriate provisions to be inserted in all subcontracts relating to this work, to bind all subcontractors to Contractor by all the terms herein set forth, insofar as applicable to the work of subcontractors and to give Contractor the same power regarding termination of any subcontract as the County may exercise over Contractor under any provisions of this contract. Nothing contained in this contract shall create any contractual relations between any subcontractor and the County or between any subcontractors.

6. Liquidated Damages The Director of Public Works may, at his discretion, deduct **Seven Hundred Dollars (\$700.00)** per day from any amount otherwise due under this contract for every day Contractor fails or refuses to prosecute the work, or any separable part thereof, with such diligence as will insure the completion by the time above specified, or any extension thereof, or fails to complete the work by such time, as long as the County does not terminate the right of Contractor to proceed. It is further provided that Contractor shall not be charged with liquidated damages because of delays in the completion of the work due to unforeseeable causes beyond Contractor's control and without fault or negligence on Contractor's part or the part of its agents.

7. Termination The County reserves the right to terminate this contract by giving at least five (5) days' prior written notice to the Contractor, without prejudice to any other rights or remedies of the County should the Contractor be adjudged as bankrupt, or if Contractor should make a general assignment for the benefit of its creditors, or if a receiver should be appointed for Contractor or for any of its property, or if Contractor should persistently or repeatedly refuse or fail to supply enough properly skilled workmen or proper material, or if Contractor should refuse or fail to make prompt payment to any person supplying labor or materials for the work under the contract, or persistently disregard instructions of the County or fail to observe or perform any provisions of the contract.

8. County's Right to Proceed In the event this contract is terminated pursuant to Paragraph 7, then the County may take over the work and prosecute the same to completion, by contract or otherwise, and Contractor and its sureties shall be liable to the County for any costs over the amount of this contract thereby occasioned by the County. In any such case the County may take possession of, and utilize in completing the work, such materials, appliance, and structures as may be on the work site and are necessary for completion of the work. The foregoing provisions are in addition to, and not in limitation of, the rights of the County under any other provisions of the contract, County regulations, and state and federal laws.

9. Indemnity The Contractor agrees to defend, indemnify, and save the County harmless from and against all claims, suits, and actions of every description, brought against the County and from all damage and costs by reason or on account of any injuries or damages received or sustained by any person or persons, or their property, by Contractor, its servants, agents, or subcontractors in the construction of said work, or by any negligence or carelessness in the performance of the same, or on account of any act or omission of Contractor, its servants, agents, or subcontractors, or arising out of the award of this contract to Contractor.

10. Payment for Labor and Materials The Contractor agrees and binds itself to pay for all labor done, and for all the materials used in the construction of the work to be completed pursuant to this contract. Contractor shall furnish to the County a bond to insure the payment of all materials and labor used in the performance of this contract. The Contractor is aware of, understands and agrees to abide by RSMo. 34.057.

11. Payment The County hereby agrees to pay the Contractor for the work done on a monthly basis pursuant to this contract according as set forth in the Contract Documents upon acceptance of said work by the Director of Public Works and in accordance with the rates and/or amounts stated in the proposal of Contractor dated January 13, 2023 which are by reference made a part hereof. No partial payment to the Contractor shall operate as approval or acceptance of work done or materials furnished hereunder.

12. Contract Time The project covered under this contract shall be completed by no later than **May 19, 2023**.

13. Contract Documents The contract documents shall consist of the following:

- a. This Contract
- b. Addenda
- c. Notice to Contractors
- d. Instructions to Bidders
- e. Signed Copy of Bid
- f. General Conditions
- g. Special Provisions
- h. Technical Specifications
- i. Drawings and/or Sketches

This contract and the other documents enumerated in this paragraph, form the Contract between the parties. These documents are as fully a part of the contract as if attached hereto or repeated herein.

14. Nondiscrimination The Contractor agrees in the performance of this contract not to discriminate on the ground or because of race, creed, color, national origin, or ancestry, sex, religion, handicap, age, or political opinion, or affiliation, against any employee of Contractor or applicant for employment and shall include a similar provision in all subcontracts let or awarded hereunder.

15. Anti-Discrimination Against Israel Act The Contractor certifies that it is not currently engaged in and shall not, for the duration of the contract, engage in a boycott of goods or services from the State of Israel; companies doing business in or with Israel or authorized by, licensed by, or organized under the laws of the State of Israel; or persons or entities doing business in the State of Israel.

16. Notices All notices required to be in writing may be given by first class mail addressed to Cole County Commission, Courthouse Annex, Room 200, 301 East High Street, Jefferson City, Missouri 65101, and **[INSERT CONTRACTOR'S NAME AND MAILING ADDRESS]**. The date of delivery of any notice shall be the second full day after the day of its mailing.

17. Jurisdiction This agreement and every question arising hereunder shall be interpreted according to the laws and statutes of the State of Missouri.

IN TESTIMONY WHEREOF, the parties have hereunto set their hands and seals as of the day and year below written.

Executed by the **COUNTY** this _____ day of _____, 2023.

Cole County Commission, Party of the First Part

Cole County Commission

ATTEST:

County Clerk (SEAL)

County Auditor
"I certify there is a balance otherwise unencumbered to the credit of the appropriation to which it is to be charged and a cash balance otherwise unencumbered in the treasury to the credit of the fund from which payment is to be incurred."

Executed by the **CONTRACTOR** this _____ day of _____, 2023.

CONTRACTOR, Party of the Second Part

By _____

Title

ATTEST:

Secretary (SEAL)

CERTIFICATE OF INSURANCE

Issued at the request of The County of COLE, Missouri

Address: Cole County Commission
Courthouse Annex, Room 200
311 East High Street
Jefferson City, Missouri 65101

THIS IS TO CERTIFY that the insured named below is at this date insured with as described in the following schedule, and in full compliance with the Contract Documents, including all contractual liability coverage.

DESCRIPTIVE SCHEDULE

Name of Insured: _____

Address of Insured: _____

Locations Covered: _____

Description of Work: _____

PERFORMANCE, PAYMENT AND ONE YEAR GUARANTEE BOND

KNOW ALL MEN BY THESE PRESENTS, that we, the undersigned _____
_____,
hereinafter referred to as "Contractor" and _____
a Corporation organized under the laws of the State of _____, and authorized to
transact business in the State of _____, as Surety, are held and firmly
bound unto the County of COLE, Missouri hereinafter referred to as "County" in the penal
sum of _____
_____ DOLLARS (\$_____),
lawful money of the United States of America for the payment of which sum, well and truly
to be made, we bind ourselves and our heirs, executors, administrators, successors, and
assigns jointly and severally by these presents.

THE CONDITION OF THE FOREGOING OBLIGATION IS SUCH THAT: WHEREAS,
the above bounden Contractor has on the _____ day of _____, 2023,
entered into a written contract with the aforesaid County for furnishing all materials,
equipment, tools, superintendence, labor, and other facilities and accessories, for the
construction of certain improvements as designated, defined, and described in the said
Contract and the Conditions thereof, and in accordance with the specifications and plans
therefore; a copy of said Contract being attached hereto and made a part hereof:

NOW THEREFORE, if the said Contractor shall and will, in all particulars, well, duly, and
faithfully observe, perform, and abide by each and every covenant, condition, and part of
the said Contract, and the Conditions, Specifications, Plans, Prevailing Wage Law, and
other Contract Documents thereto attached or, by reference, made a part thereof,
according to the true intent and meaning in each case, and if said contractor shall replace
all defective parts, material and workmanship for a period of one year after acceptance
by the County, then this Obligation shall be and become null and void; otherwise it shall
remain in full force and effect.

PROVIDED FURTHER, that if the said Contractor fails to duly pay for any labor, materials,
sustenances, provisions, provender, gasoline, lubricating oils, fuel oils, greases, coal
repairs, equipment, and tools consumed or used in said work, groceries and foodstuffs,
and all insurance premiums, compensation liability, and otherwise, or any other supplies
or materials used or consumed by such Contractor or his, their, or its subcontractors in
performance of the work contracted to be done, the Surety will pay the same in any
amount not exceeding the amount of this Obligation, together with interest as provided by
law:

PROVIDED FURTHER, that the said Surety, for value received, to be performed
thereunder, or the specifications accompanying the same, shall in any way affect its
obligation on this bond and it does hereby waive notice of any change, extension of time,
alteration, or addition to the terms of the Contract, or to the work, or to the specifications:

PROVIDED FURTHER, that if said Contractor fails to pay the prevailing hourly rate of wages, as shown in the attached schedule, to any workman engaged in the construction of the improvements as designated, defined and described in the said Contract, specifications and conditions thereof, the Surety will pay the deficiency and any penalty provided for by law which the Contractor incurs by reason of (his/its) act or omission, in any amount not exceeding the amount of this obligation together with interest as provided by law:

IN TESTIMONY WHEREOF, the said Contractor has hereunto set his hand, and the said Surety has caused these presents to be executed in its name, and its corporate seal to be hereunto affixed, by it attorney-in-fact duly authorized thereunto so to do, at _____ this the _____ day of _____, 20____.

SURETY COMPANY

CONTRACTOR

By _____ (SEAL)

By _____ (SEAL)

By _____ (SEAL)
Attorney-in-Fact

By _____ (SEAL)
(State Representative)

(Accompany this bond with Attorney-in-Fact's authority from the Surety Company certified to include the date of the bond.)

Missouri

Division of Labor Standards

WAGE AND HOUR SECTION



MICHAEL L. PARSON, Governor

Annual Wage Order No. 29

Section 026
COLE COUNTY

In accordance with Section 290.262 RSMo 2000, within thirty (30) days after a certified copy of this Annual Wage Order has been filed with the Secretary of State as indicated below, any person who may be affected by this Annual Wage Order may object by filing an objection in triplicate with the Labor and Industrial Relations Commission, P.O. Box 599, Jefferson City, MO 65102-0599. Such objections must set forth in writing the specific grounds of objection. Each objection shall certify that a copy has been furnished to the Division of Labor Standards, P.O. Box 449, Jefferson City, MO 65102-0449 pursuant to 8 CSR 20-5.010(1). A certified copy of the Annual Wage Order has been filed with the Secretary of State of Missouri.

Original Signed by _____

Todd Smith, Director
Division of Labor Standards

Filed With Secretary of State: _____ **March 10, 2022**

Last Date Objections May Be Filed: **April 11, 2022**

Prepared by Missouri Department of Labor and Industrial Relations

| OCCUPATIONAL TITLE | **Prevailing Hourly Rate |
|------------------------------|--------------------------------|
| Asbestos Worker | \$53.18 |
| Boilermaker | \$27.22* |
| Bricklayer | \$51.39 |
| Carpenter | \$47.88 |
| Lather | |
| Linoleum Layer | |
| Millwright | |
| Pile Driver | |
| Cement Mason | \$41.24 |
| Plasterer | |
| Communications Technician | \$55.00 |
| Electrician (Inside Wireman) | \$55.64 |
| Electrician Outside Lineman | \$74.20 |
| Lineman Operator | |
| Lineman - Tree Trimmer | |
| Groundman | |
| Groundman - Tree Trimmer | |
| Elevator Constructor | \$27.22* |
| Glazier | \$56.16 |
| Ironworker | \$61.89 |
| Laborer | \$41.21 |
| General Laborer | |
| First Semi-Skilled | |
| Second Semi-Skilled | |
| Mason | \$27.22* |
| Marble Mason | |
| Marble Finisher | |
| Terrazzo Worker | |
| Terrazzo Finisher | |
| Tile Setter | |
| Tile Finisher | |
| Operating Engineer | \$60.02 |
| Group I | |
| Group II | |
| Group III | |
| Group III-A | |
| Group IV | |
| Group V | |
| Painter | \$39.08 |
| Plumber | \$66.28 |
| Pipe Fitter | |
| Roofer | \$51.92 |
| Sheet Metal Worker | \$54.06 |
| Sprinkler Fitter | \$62.10 |
| Truck Driver | \$41.74 |
| Truck Control Service Driver | |
| Group I | |
| Group II | |
| Group III | |
| Group IV | |

*The Division of Labor Standards received fewer than 1,000 reportable hours for this occupational title. The public works contracting minimum wage is established for this occupational title using data provided by Missouri Economic Research and Information Center.

**The Prevailing Hourly Rate includes any applicable fringe benefit amounts for each occupational title as defined in Section 290.210 RSMo.

Heavy Construction Rates for
COLE County

Section 026

| OCCUPATIONAL TITLE | **Prevailing Hourly Rate |
|-------------------------------|--------------------------|
| Carpenter | \$53.63 |
| Millwright | |
| Pile Driver | |
| Electrician (Outside Lineman) | \$74.20 |
| Lineman Operator | |
| Lineman - Tree Trimmer | |
| Groundman | |
| Groundman - Tree Trimmer | |
| Laborer | \$43.21 |
| General Laborer | |
| Skilled Laborer | |
| Operating Engineer | \$58.94 |
| Group I | |
| Group II | |
| Group III | |
| Group IV | |
| Truck Driver | \$45.80 |
| Truck Control Service Driver | |
| Group I | |
| Group II | |
| Group III | |
| Group IV | |

Use Heavy Construction Rates on Highway and Heavy construction in accordance with the classifications of construction work established in 8 CSR 30-3.040(3).

Use Building Construction Rates on Building construction in accordance with the classifications of construction work established in 8 CSR 30-3.040(2).

If a worker is performing work on a heavy construction project within an occupational title that is not listed on the Heavy Construction Rate Sheet, use the rate for that occupational title as shown on the Building Construction Rate Sheet.

*The Division of Labor Standards received fewer than 1,000 reportable hours for this occupational title. The public works contracting minimum wage is established for this occupational title using data provided by Missouri Economic Research and Information Center.

**The Prevailing Hourly Rate includes any applicable fringe benefit amounts for each occupational title as defined in Section 290.210 RSMo.

OVERTIME and HOLIDAYS

OVERTIME

For all work performed on a Sunday or a holiday, not less than twice (2x) the prevailing hourly rate of wages for work of a similar character in the locality in which the work is performed or the public works contracting minimum wage, whichever is applicable, shall be paid to all workers employed by or on behalf of any public body engaged in the construction of public works, exclusive of maintenance work.

For all overtime work performed, not less than one and one-half (1½) the prevailing hourly rate of wages for work of a similar character in the locality in which the work is performed or the public works contracting minimum wage, whichever is applicable, shall be paid to all workers employed by or on behalf of any public body engaged in the construction of public works, exclusive of maintenance work or contractual obligation. For purposes of this subdivision, "**overtime work**" shall include work that exceeds ten hours in one day and work in excess of forty hours in one calendar week; and

A thirty-minute lunch period on each calendar day shall be allowed for each worker on a public works project, provided that such time shall not be considered as time worked.

HOLIDAYS

January first;
The last Monday in May;
July fourth;
The first Monday in September;
November eleventh;
The fourth Thursday in November; and
December twenty-fifth;

If any holiday falls on a Sunday, the following Monday shall be considered a holiday.

JOB SPECIAL PROVISIONS

JOB SPECIAL PROVISIONS TABLE OF CONTENTS

(Job Special Provisions shall prevail over General Special Provisions whenever in conflict therewith.)

- A. General
- B. Contract Liquidated Damages
- C. Work Zone Traffic Management Plan
- D. Emergency Provisions and Incident Management
- E. Project Contact for Contractor/Bidder Questions
- F. Utilities
- G. Earthwork
- H. Pre-Construction Conference
- I. Permits
- J. Construction Staking
- K. Property Corners and Monumentation
- L. Removal of Improvements
- M. Clearing and Grubbing
- N. Tree Removal
- O. Drainage
- P. Protection of Adjacent Properties
- Q. Topsoil in Areas to be Seeded or Sodded
- R. Lawn Restoration
- S. Removal and Replacement of Landscaping Features
- T. Roof Drains and Foundation Drains
- U. Pavement Removal and Replacement
- V. Segmental Block Retaining Wall

| | |
|---|---|
|  | <p>COLE COUNTY PUBLIC WORKS 5055 MONTICELLO RD. JEFFERSON CITY, MO 65109 Phone 573-636-3614</p> |
| | <p>PROJECT NUMBER: 2022-201-1 LAKEWOOD SUBDIVISION DATE PREPARED: 12-15-22</p> |
| <p>Date: 12-15-22</p> | <p>ADDENDUM DATE:</p> |
| <p>Only the following items of the Job Special Provisions (Roadway) are authenticated by this seal: All</p> | |

JOB SPECIAL PROVISIONS

A. GENERAL

1.0 The Technical Specification for this project shall consist of the latest effective version of the Missouri Standard Specifications for Highway Construction except as modified or contradicted by the County's Contract, Special Provisions, General Provisions, and Plans.

2.0 The standard drawings for this project shall consist of the latest effective edition of the City of Jefferson Standard Drawings except as modified or contradicted by the County's Contract, Special Provisions, General Provisions, and Plans.

2.1 Copies of the City of Jefferson Standard Drawings may be found on the City's website at https://www.jeffersoncitymo.gov/government/developer_resources_forms.php and are available upon request from the County.

3.0 The contractor shall familiarize himself with these drawings and specifications prior to bidding. Failure to do so shall not relieve the contractor from delivering the completed project in accordance with the intent of the Plans and Specifications to provide a workable project.

3.1 All construction details included with the plans and attached hereto shall be used in constructing this project.

B. CONTRACT LIQUIDATED DAMAGES

1.0 Description. Liquidated Damages for failure or delay in completing the work on time for this contract shall be in accordance with Sec 108.8.

2.0 Completion Date. Regardless of when the work is begun on this contract, all work shall be completed on or before the date specified below. Completion by this date shall be in accordance with the requirements of Sec 108.7.

Completion Date: May 19, 2023

2.1 Should the contractor, or in case of default, the surety, fail to complete the work before or by the above specified date, a deduction of the amount shown below will be made for each day that the contract remains uncompleted in accordance with the requirements of Sec 108.8. These damages are in addition to any other damages as specified elsewhere in this contract.

Liquidated Damages Per Day: \$700.00

C. WORK ZONE TRAFFIC MANAGEMENT

1.0 Description. Work zone traffic management supplied by the contractor shall be in accordance with applicable portions of Division 100 and Division 600 of the Standard Specifications, and specifically as follows.

2.0 Work Hour Restrictions. There are no work hour restrictions for this project. It shall be the responsibility of the engineer to determine if work hours may be modified. Working hours for evenings, weekends and holidays will be determined by the engineer.

JOB SPECIAL PROVISIONS

3.0 Lane Closures.

3.1 The contractor shall notify the emergency response agencies prior to any closures. The contractor shall submit a schedule of closure to the engineer **TWO WEEKS** prior to a lane closure. The engineer must approve the schedule prior to any work beginning.

3.2 The road may be closed to thru traffic during construction, but local traffic must have access to the area at all times.

3.3 When closing the road, the contractor shall place Type III Movable Barricades with R11-2 signs and Type C warning lights at the road closure. The contractor shall also place cones at all open cuts in the roadway until final pavement is in place. If the contractor has to do any miscellaneous work before and/or after the road closures, or when equipment is in the road, he shall provide temporary traffic control. All traffic control shall be in accordance with the latest edition of the Manual on Uniform Traffic Control Devices (MUTCD). This shall include, but not be limited to, signing, flagging, cones, etc.

4.0 Property Owner Coordination. Contractor must coordinate with adjacent property owners to schedule the work. Contractor shall provide property owners access to their property at all times by use of phased construction, shared entrances, temporary entrances, or other means necessary. Property access closures may be allowed with permission of property owner and approval of the engineer.

5.0 Basis of Payment. Any expenses incurred by the contractor by reason of their compliance with this provision shall be considered as completely covered by the contract unit price for "Traffic Control" per lump sum.

D. EMERGENCY PROVISIONS AND INCIDENT MANANGEMENT

1.0 The contractor shall have communication equipment on the construction site or immediate access to other communication systems to request assistance from law enforcement or other emergency agencies for incident management. In case of traffic accidents or the need for law enforcement to direct or restore traffic flow through the job site, the contractor shall notify law enforcement or other emergency agencies immediately as needed. The project contact's office shall also be notified when the contractor requests emergency assistance.

2.0 In addition to the 911 emergency telephone number for ambulance, fire or law enforcement services, the following agencies may also be notified for accident or emergency situation within the project limits.

| | |
|--------------------------------------|---|
| Cole County Sheriff | (573) 634-9160 |
| Cole County EMS | (573) 634-2616 |
| Cole County Fire Protection District | 911 (Emergency) (573) 634-9011 (Non-Emergency) |
| Missouri State Highway Patrol | (573) 751-1000 |

JOB SPECIAL PROVISIONS

2.1 This list is not all-inclusive. Notification of the need for wrecker or tow truck services will remain the responsibility of the appropriate law enforcement agency.

2.2 The contractor shall notify law enforcement and emergency agencies before the start of construction to request their cooperation and to provide coordination of services when emergencies arise during the construction at the project site. When the contractor completes this notification with law enforcement and emergency agencies, a report shall be furnished to the engineer on the status of incident management.

3.0 No direct pay will be made to the contractor to recover the cost of the communication equipment, labor, materials, or time required to fulfill the above provisions.

E. PROJECT CONTACT FOR CONTRACTOR/BIDDER QUESTIONS

1.0 All questions concerning the bidding process, specifications and plans for this project shall be forwarded to the project contact listed below.

Mattheuw Prenger, P.E., Project Contact
County Engineer
Cole County Public Works
5055 Monticello Road
Jefferson City, MO 65109

Telephone Number (573) 636-3614
Fax Number (573) 636-8389
E-mail: mprenger@colecourt.org

F. UTILITIES

1.0 The location and extent of the existing underground utilities and utilities are not shown on the plans. It shall be the sole responsibility of the contractor to locate, protect, and restore all existing utilities encountered on the project. Notify Missouri One Call (1-800-DIG-RITE or 811) for location of the utilities at least five days prior to construction.

1.1 The contractor shall be aware of the presence of utilities above and/or below the ground or in the vicinity of this project that may interfere with their operations. The contractor expressly acknowledges and assumes this risk even though the nature and extent is unknown to both the contractor and the owner at the time of bidding and award of the contract. The effect in cost or time of the presence of utilities above, below or in the vicinity of the contractor's work under this contract shall not be compensable.

1.3 The contractor shall be solely responsible and liable for incidental and consequential damage to any utility facilities or interruption of the service caused by it or its subcontractors operations. The contractor shall hold and save harmless the owner from damages to any utility facilities interruption of service by it or its subcontractor's operation.

1.4 The contractor shall coordinate with utility companies to allow the utilities to inspect any exposed lines that are to remain in place before being backfilled. Any damage to the utilities that occurred during construction shall be repaired or replaced at the expense of the contractor.

JOB SPECIAL PROVISIONS

2.0 Basis of Payment. No direct pay will be made to the contractor to recover the cost of the communication equipment, labor, materials or time required to fulfill the above provisions, unless otherwise noted.

G. EARTHWORK

1.0 Description. This work shall consist of all grading and excavation work required or necessary for the total completion of the project, except as noted elsewhere.

1.1 Typical earthwork items on this project shall consist of, but not be limited to:

- Excavation of poor soil in the yard areas.
- Furnishing and placing top soil in the yard areas.
- Excavation and backfill curb and gutter.
- Excavation and backfill at inlets.
- Fill areas for proper yard drainage.
- Excavating or filling to the limits shown on the plans.
- Excavation and backfill for pipe.
- Hauling of waste material off site.

2.0 Construction Requirements.

2.1 Grading activities shall conform to Sec 203 and other applicable areas of the Standard Specification.

2.2 All excavation that is required for storm sewer installation shall be included in the unit bid price of pipe per linear foot and also shall be included in the unit bid price of inlet per each. There will be no separate payment for any rock excavation that is encountered.

3.0 Method of Measurement. No measurements will be made and contract quantity will be used.

4.0 Basis of Payment. All costs incurred for equipment, labor, materials, or time required to fulfill this provision, except as noted above, shall be considered completely covered by the contract unit price for "Earthwork", per lump sum.

H. PRE-CONSTRUCTION CONFERENCE

1.0 Prior to starting work, a pre-construction conference will be held to discuss the project, it's scheduling and it's coordination with the work of others. It is expected that this conference will be attended by representatives of the Owner, the Engineer, the Contractor and his Subcontractors, and the Utilities, as well as representatives of any other affected agencies.

1.1 It shall be required that all of the contractor's designated foremen that will oversee field operations of the project will attend the conference.

1.2 The work schedule specified in the Instructions to Bidders will be submitted at the conference.

JOB SPECIAL PROVISIONS

I. PERMITS

1.0 MoDNR Land Disturbance Permit. The county of Cole has obtained a General Operating Permit (Permit No. MO-R100034) from the Missouri Department of Natural Resources, Water Protection for construction and land disturbance activity, which covers the work entailed in the project. The County's associated Storm Water Pollution Prevention Plan (SWPPP), which is a requirement to the General Operating Permit, is attached as part of the contract documents.

1.1 In signing the contract, the contractor obligates himself to follow the provisions of the permit and the associated Storm Water Pollution Prevention Plan. The Contractor shall obtain a copy of the permit and SWPPP prior to beginning construction. Specifically, the contractor shall be responsible for:

- a) All required inspections of erosion control BMP's.
- b) Maintaining records of precipitation.
- c) Maintaining logs of BMP Inspections, BMP Maintenance and BMP Corrective Actions taken to correct deficiencies identified during inspections.
- d) Documenting any changes made to the Erosion Control Plan.

2.0 Basis of Payment. All expenses incurred by the Contractor by reason of their compliance with this provision shall be considered as completely covered by each of the appropriate pay items included in the contract.

J. CONSTRUCTION STAKING

1.0 Construction staking for this project will be performed by the County or its agent. The contractor shall provide one week's notice of any staking he wishes to have performed. Any restaking required due to the destruction of the original stakes shall be the responsibility of the contractor.

K. PROPERTY CORNERS AND MONUMENTATION

1.0 It shall be the responsibility of the Contractor to protect all property lot corners and land survey corners and accessories. Should it be necessary to disturb any such monument, whether stake, pin, bar, disk, box, or other, the Contractor shall contact the County prior to construction. The County will reference such markers prior to removal and reset them after construction. The Contractor shall allow the County a minimum of two working days to reference such markers.

2.0 No direct payment will be made to the contractor for the requirements of this provision.

L. REMOVAL OF IMPROVEMENTS

1.0 All removal of improvements necessary for the completion of the project in accordance with the plans shall be considered completely covered by the contract unit price for "Removal of Improvements", per lump sum. These removal items shall consist of, but not be limited to:

- Concrete curb and gutter.
- Asphalt and concrete pavement.
- Pipe and inlet removal.

JOB SPECIAL PROVISIONS

- Trees, bushes and objectionable vegetation.
- Removal of existing corrugated metal pipe.
- Retaining wall and fence.
- Concrete flume.

M. CLEARING AND GRUBBING

1.0 There will be no direct payment for clearing and grubbing as needed on this project. All costs shall be completely covered by the unit prices for other items.

N. TREE REMOVAL

1.0 The contractor shall remove all trees as directed by the engineer in the field. Trees must be removed and hauled off. Stumps shall be removed completely or ground a minimum of 18" below the surface.

2.0 Basis of Payment. Any expenses incurred by the contractor by reason of their compliance with this provision shall be considered as completely covered by the contract unit price for "Removal of Improvements", per lump sum.

O. DRAINAGE

1.0 Description. This work includes installation of a storm sewer system consisting of pipes, inlets, junction boxes, and flared end sections.

2.0 Requirements. Dimensions and details of the inlets and junction boxes shall be according to the City of Jefferson Standard Details. Dimensions and details for the pipe shall be in accordance with the plans and specifications and the applicable section of the currently effective Missouri Standard Specifications for Highway Construction and Missouri Standard Plans for Highway Construction.

2.1 The construction and materials for any necessary removal and replacement of the inlet wall to facilitate the pipe installation shall conform to Sec 731.

2.2 The construction and materials for the concrete junction box shall conform to Sec 731. **The inlets shall be cast-in-place to allow for field adjustments as needed.**

2.3 Pipe. Corrugated plastic pipe shall be High Density Polypropylene (HDPP) and grey in color.

3.0 Method of Measurement. Measurement of pipe shall be to the nearest 1.0 linear foot. Flared end section shall be measured per each. Inlets shall be measured per each.

4.0 Basis of Payment. Excavation and backfill shall be included with the price for the pipe and inlets. If rock is encountered, there will be no additional payment.

4.1 All expenses incurred by the Contractor by reason of their compliance with this provision shall be considered completely covered by the contract unit prices for pipe, flared end section and inlets.

P. PROTECTION OF ADJACENT PROPERTIES

1.0 Surface water shall be diverted and otherwise prevented from entering or damaging adjacent property as a result of precipitation during construction.

Q. TOPSOIL IN AREAS TO BE SEEDED

1.0 The top six (6) inches of all areas of the project to be vegetated shall be free of rocks, stones and clods prior to seeding or sodding. This may require the contractor to utilize a mechanical rock rake, hand picking of stones, and/or placement of six (6) inches of clean topsoil in those areas to be vegetated. All areas to be vegetated shall be inspected prior to seeding and any deficiency shall be correct prior to application.

2.0 Basis of Payment. All costs associated with the work specified under this provision shall be considered completely covered by the various items of work in the contract.

R. LAWN RESTORATION

1.0 Description. Final grade shall be established and seeded, fertilized and mulched or sodded within 10 working days of proposed improvements being completed on a property unless approved otherwise by the Engineer.

1.1 All disturbed areas of the project no paved or concrete shall be seeded or sodded as noted on the plans.

2.0 Seeding.

2.1 The seed mixture shall be Turf Type Tall Fescue, sourced locally and commonly referred to as Triple T. The seeding rate shall be 350 lbs/acre (0.72 lb/sy).

2.2 Fertilizer shall be a standard commercial product which, when applied at the proper rates, shall supply the quantity of total nitrogen (N), available phosphoric acid (P₂O₅) and soluble potash (K₂O) to provide a final mixture of 13-13-13. The rate of application shall be 500 pounds per acre of 13-13-13 fertilizer. Material may be accepted on the basis of bag label analysis or supplier's certification, or on the basis of samples tested in the laboratory. For samples tested in the laboratory, tolerances in the nominal composition as shown by label or certification of 10 percent up to the maximum of two units (2% plant food) for the individual constituents, and minus 3 percent for the sum of the constituents will be permitted. There is no limit on the plus tolerances for such samples.

2.3 Type 1 Mulch (Vegetative) shall be applied at the rate of 1 ½ tons per acre.

3.0 Sodding.

3.1 Sodding shall be Black Beauty Tall Fescue sourced locally.

JOB SPECIAL PROVISIONS

4.0 Method of Measurement.

4.1 The contractor shall restore all disturbed areas as noted on the plans. A measurement will not be made. The contractor can control the extents of their restoration efforts based on their ability to minimize lawn disturbance.

5.0 Basis of Payment. All costs incurred by the contractor for labor, equipment and materials in compliance with the above requirements, including seedbed preparation, liming, furnishing and placing fertilizer and mulch, shall be considered completely covered by the contract unit price for "Lawn Restoration", per lump sum.

5.1 Payment for seeding work will be made on the following schedule:

- 50% paid after seeding, fertilizing and mulch or sodding is placed.
- 50% paid after seeding or sodding has been established and the County accepts it.

S. REMOVAL AND REPLACEMENT OF LANDSCAPING FEATURES

1.0 The contractor shall contact all property owners concerning the removal of any landscaping features impacted by construction prior to beginning work. Care shall be taken in order to cause the least disruption to yard areas, plants, shrubs, trees, etc. Any landscaping that is necessary to be removed shall be done so in a way such that the property owner can salvage it if desired. The contractor shall coordinate all removals with the property owner and if necessary shall assist the property owner with relocation.

2.0 No direct payment will be made to the contractor for the requirements of this provision.

T. ROOF DRAINS AND FOUNDATION DRAINS

1.0 Description. This work shall include connecting existing downspouts and other drains through and into the proposed curb, curb and gutter or storm sewer facility. Sump pumps shall be connected to a pipe or inlet in the storm sewer system. The location of some downspout drains may be shown on the plans, but other drains may exist that are not shown. The Contractor shall be responsible to connect all downspout drains regardless of whether or not they are shown on the plans.

2.0 Construction Methods. The Contractor shall exercise care in removing existing facilities so as to minimize damage to existing drains. New material of the same diameter as the existing drain shall be used.

3.0 Basis of Payment. All work associated with connecting downspout drains through or into the proposed curb, curb and gutter or storm sewer facility shall be subsidiary to the item to which it is connected. No direct payment will be made.

U. PAVEMENT REMOVAL AND REPLACEMENT

1.0 Description. This work consists of removing pavement in areas where storm sewer pipes cross the road and replacing with concrete.

JOB SPECIAL PROVISIONS

2.0 Construction Requirements. The Contractor shall remove the pavement in a manner approved by the Engineer. All saw cuts shall be neat and straight to provide a vertical face for concrete replacement.

2.1 All pavement removed for installation of cross road pipes shall be replaced with 8" of non-reinforced concrete over 4" of Type 5 Aggregate Base. All new pavement shall be doweled into the adjacent concrete pavement and top elevation and slope shall match that of surrounding pavement.

3.0 Basis of Payment. All expenses incurred by the Contractor for removal of existing pavement shall be considered as completely covered by the contract unit price for "Removal of Improvements", per lump sum.

3.1 All expenses incurred by the Contractor for pavement replacement, including the Type 5 Aggregate Base, shall be considered as completely covered by the contract unit price for "8" Non-Reinforced Concrete Pavement", per square yard.

V. SEGMENTAL BLOCK RETAINING WALL

1.0 Description. The existing segmental block retaining wall shall be removed and the blocks shall be stockpiled. Once pipe C-4 is installed, the segmental block retaining wall shall be reinstalled and constructed in accordance with Section 720, off of Right of Way as shown on the plans.

1.1 Any additional block needed to construct the replacement wall shall match the existing block in terms of color, size, and texture, or as directed by the Engineer.

2.0 Basis of Payment: All expenses incurred by the Contractor for removal and stockpiling of the segmental block retaining wall shall be considered as completely covered by the unit price for "Removal of Improvements", per lump sum.

2.1 All expenses incurred by the Contractor for reinstalling the wall shall be considered as completely covered by the contract unit price for "Segmental Block Retaining Wall", per square foot.

GENERAL SPECIAL PROVISIONS

The General Special Provisions for this particular Cole County project shall consist of the currently corrected (2004) version of the *Missouri Standard Specifications for Highway Construction*, Sections 101 through 110, except as modified or contradicted herein.

SECTION 101.2 - DEFINITION OF TERMS

Delete definition for “Commission” and substitute the following:

If the words "Commission" or "The Missouri Highway and Transportation Commission" are used in the *Missouri Standard Specifications for Highway Construction*, the word "Owner" shall be substituted, and shall mean the County of COLE acting by and through any of its authorized representatives.

Delete definition for “Contract” and substitute the following:

Contract. The written agreement between the Owner and the Contractor covering the performance of the work for the proposed construction. The contract shall include Notice to Contractors, Instruction to Bidders, Plans, Proposal, Addenda, Contract Bond, Contract Agreement, Acknowledgment, Special Provisions, Standard Specifications, Notice to Proceed, and all Supplemental Contracts and Change Orders. It may cover a single project, or a combination of projects awarded as a single unit.

Delete definition for “Engineer” and substitute the following:

If the words "Engineer" or "Chief Engineer" are used in the *Missouri Standard Specifications for Highway Construction*, the word "Engineer" shall be substituted, and shall mean the County Engineer acting by and through any of his authorized representatives.

Delete definition for “Laboratory” and substitute the following:

Laboratory. Any testing laboratory which may be designated by the Engineer, for inspecting and determining the suitability of materials.

Delete definition for “Plans” and substitute the following:

Plans. Drawings or reproductions thereof approved by the Owner, which show the location, character, and details of the work. Plans shall prevail over standard specifications, general special provisions, and job special provisions when in conflict therewith.

Insert the following definition for “Job Special Provision” where none currently exists:

Job Special Provisions. Directions or requirements, peculiar to the work and not otherwise thoroughly or satisfactorily detailed or set forth in the standard specifications.

Job special provisions shall prevail over general special provisions, and general special provisions shall prevail over standard specifications whenever in conflict therewith.

Delete definition for “State” and substitute the following:

If the words "State" or "State of Missouri" are used in such a manner which implies ownership of the project, the word "Owner" shall be substituted and shall mean the County of COLE acting by and through any of its authorized representatives.

SECTION 102 - BIDDING REQUIREMENTS AND CONDITIONS

Delete Sec. 102.1 and substitute the following:

102.1 Notice of Bid Opening. After the date is fixed for the receipt of bids, the Owner may, in addition to the notice required by law, give notice of such date by mail directly to interested Contractors. The Notice of Letting will contain a description of the proposed work, together with instructions and information to the potential bidder regarding proposal forms, plans, specifications, and the reservation of the right of the Owner to reject any and all bids.

Delete Sec. 102.2 thru Sec. 102.2.1 and substitute the following:

102.2 Bidder’s Qualifications. To demonstrate his qualifications for the project, each bidder must be prepared to submit within seven (7) calendar days of the Owner’s request, written evidence as to the Contractor’s financial status, equipment, previous experience and personnel.

Delete Sec. 102.2.2 and substitute the following:

102.2.2 Each prospective bidder shall execute the affidavit of labor standards compliance, stating that such bidder will fully comply with all written requests by the Missouri Department of Labor and Industrial Relations, Division of Labor Standards, to provide information for the purpose of establishing a prevailing wage.

Delete Sec. 102.2.3 and substitute the following:

102.2.3 The prospective bidder, if a corporation, shall submit a copy of its current annual registration report, or initial registration report if a new corporation, on file with the Corporation Division of the Missouri Secretary of State’s Office. Each corporation which is a party to a joint venture shall submit the same required report with its joint venture contractor.

Delete 102.6 and substitute the following:

102.6 Sales and Use Taxes. The sales tax exemption for public works contractors of certain entities, enacted in 1994 in Section 144.062 RSMo, may apply to contractors for the Owner or their subcontractors or suppliers. This exemption is for materials consumed in the construction of, or incorporated into this project. The Owner will judge

each project and determine if the sales tax exemption of the Owner will apply. If sales tax exemption is allowed on a project, it will be duly noted on the proposal form. The Owner will make the tax exemption certificate available, if applicable, to the successful bidder upon award of this contract. If the Owner does not allow the use of sales tax exemption, the contractor, subcontractor or suppliers shall pay all applicable state and local sales taxes or state use taxes on all material and supplies used on a project and should include those taxes in their bid.

Delete 102.7.2 in its entirety.

Delete Sec. 102.7.3 and substitute the following:

102.7.3 A bid of an individual, including those doing business under a fictitious name, shall include the signature and address of the individual.

Delete Sec. 102.7.4 and substitute the following:

102.7.4 A bid by a partnership or joint venture, including individuals doing business under fictitious names, or corporations, shall be executed by at least one of the partners followed by the title "Partner", or one of the joint venturers followed by the title "Joint Venturer" and the business address of the partnership or joint venturer shown. The true legal name and address of each partner and joint venturer shall also be shown.

Delete Sec. 102.7.5 and substitute the following:

102.7.5 A bid by a corporation whether acting alone or as a joint venturer, shall show the address and name of the corporation and shall include the signature and title of a person authorized by its board of directors to bind the corporation.

Add Section 102.7.9

102.7.9 All names must be typed or printed in ink below all signatures.

Add Section 102.7.10

102.7.10 The bid shall contain an acknowledgement of receipt of all addenda (the number and dates of which shall be filled in on the Proposal Form).

Add Section 102.7.11

102.7.11 All bidders shall complete and submit with their proposal the following forms included in the bid documents.

- (a) Proposal
- (b) Signature and Identity of Bidder
- (c) Bid Guaranty
- (d) Contractor's Affidavit
- (e) Anti-Collusion Statement

Delete Sec. 102.9 and substitute the following:

102.9 Bid Guaranty. No proposal will be considered unless accompanied by a certified check or cashier's check, on any bank or trust company, insured by the Federal Deposit Insurance Corporation, payable to the Owner, for not less than 5 percent of the amount of the bid, or by a bond secured by a qualified surety, or sureties, for not less than 5 percent of the amount of the bid. Surety companies shall furnish a Certificate of Authority in accordance with Section 103.4.2. Bid bonds may be submitted on forms furnished in these Contract documents. The proposal Guaranty shall be attached to the back of the bid proposal form.

Delete Sec. 102.10 and substitute the following:

102.10 Delivery of Proposals. Each proposal shall be submitted in a sealed, opaque envelope marked clearly "Construction Bid" and shall also be clearly marked with project title, project number, bid date, bid time and bidder's name and address. If sent by mail, the sealed bid shall be addressed to the Cole County Commission, Courthouse Annex, Room 200, 311 East High Street, Jefferson City, Missouri, 65101. All proposals shall be filed prior to the time and at the place specified in the Notice To Bidders. Proposals received after the time for opening of bids will be returned to the bidder unopened. No bids which are submitted by fax will be accepted.

SECTION 103 - AWARD AND EXECUTION OF CONTRACT

Delete Sec. 103.2.1 and substitute the following:

103.2.1 The contract will be awarded by the Owner to the lowest responsible bidder as soon as practicable after the opening of the bids. The responsibility of the Contractor will be determined by the Owner based upon, but not limited to the Contractor's previous work, financial standing, and record for the payment of local bills incurred by the Contractor, his employees, and subcontractors. The successful bidder will be notified by letter mailed to the address shown on the proposal that his bid has been accepted and that he has been awarded the contract.

Delete Sec. 103.4.1 and substitute the following:

103.4.1 The successful bidder shall, at the time of the execution of the contract, furnish a contract bond in a sum equal to the contract price. The bond shall be to the Owner, in a form and with surety, or sureties, acceptable to the Owner, to insure the proper and prompt completion of the work in accordance with the provisions of the contract, and to insure payment for all labor performed and materials consumed or used in the work. The bond, if executed by a surety which is a corporation organized in a state other than Missouri, shall be signed by an agent or broker licensed by the Missouri Division of Insurance. All proposals shall be submitted on the basis of furnishing a contract bond executed by an approved surety, or sureties, as herein set out.

SECTION 104 - SCOPE OF WORK

Add Sec. 104.6.3.5

104.6.3.5 All proposals shall be submitted to the Engineer. If so desired, the Contractor may submit a conceptual proposal for approval stating the basic proposal and approximate cost savings. The conceptual proposal will give the Contractor the opportunity to submit his idea without large initial development costs should the proposal be rejected.

Delete Sec. 104.11.2 and substitute the following:

104.11.2 The Contractor shall open and clean all existing channels and culverts leaving them free from all excess mud or silt, drift, brush, and debris of any kind. This work shall be considered incidental to the work, and no direct payment shall be made for work covered by this section.

Delete Sec. 104.13 in its entirety and substitute the following:

104.13 Warranty.

104.13.1 The Contractor shall warranty that the equipment, materials, and workmanship furnished under this contract will be as specified and will be free from defects for a period of one (1) year from the date of final acceptance. In addition, the equipment furnished by the Contractor shall be warranted to be free from defects in design.

104.13.2 Within the warranty period and upon notification of the Contractor by the Owner, the Contractor shall promptly make all needed adjustments, repairs, or replacements arising out of defects which, in the judgment of the Engineer, or the County, become necessary during such period.

104.13.3 The cost of all materials, parts, labor, transportation, supervision, special tools, and supplies required for replacement of parts, repair of parts, or correction of abnormalities shall be paid by the Contractor, or by his surety under the terms of the bond.

104.13.4 The Contractor shall extend the terms of this warranty to cover repaired parts and all replacement parts furnished under the guarantee provisions for a period of one (1) year from the date of installation thereof.

104.13.5 If within ten (10) days after the Owner gives the Contractor notice of a defect, failure, or abnormality of the work, the Contractor neglects to make, or undertake with due diligence to make, the necessary repairs or adjustments themselves or order the work to be done by a third party, the Owner may complete the work and the costs of the work shall be paid by the Contractor.

104.13.6 In the event of an emergency where, in the judgment of the Owner, delays would cause serious loss or damage, repairs or adjustments may be made by the Owner,

or a third party chosen by the Owner, without giving notice to the Contractor, and the cost of the work shall be paid by the Contractor, or by his surety under the terms of the bond.

104.13.7 No direct payment will be made for complying with the requirements of this section.

SECTION 105 - CONTROL OF WORK

Delete Sec. 105.5 and substitute the following:

105.5 Cooperation by Contractor. The Contractor will be supplied with four (4) sets of approved plans and contract assemblies including special provisions. Additional sets of approved plans and contract assemblies including special provisions may be purchased as provided in the notice to bidders. One (1) set of approved plans and contract documents including special provisions shall be kept available on the job at all times.

Add Sec. 105.5.3:

105.5.3 The Contractor shall notify the Engineer not less than four (4) working days prior to closing the road.

Delete Sec. 105.7.1 and substitute the following:

105.7.1 The Contractor shall cooperate with utility owners and the Engineer in the location and relocation of utility facilities to minimize effects upon Contractor's work, interruption to utility service and duplication of work by utility owners. The Contractor shall perform the necessary clearing and grubbing as soon as practicable after the notice to proceed is issued to allow the utilities to locate or relocate their facilities. Facilities or appurtenances that are to remain in place during construction shall be accounted for and protected by the Contractor's work procedures. Utility location and relocation shall be made in accordance with 7 CSR Division 10, Chapter 3, Utility Location and Relocation.

Add Section 105.7.7

105.7.7 The Contractor shall make suitable and timely verbal and written requests to all utility locating agencies, all railroad and utility owners, all pipe owners, and other parties affected, and endeavor to have all necessary locates and adjustments of public or private utility fixtures, pipe lines, and other appurtenances within or adjacent to the limits of construction, made as soon as practicable. One (1) copy of all requests shall be submitted to the Engineer.

Delete Sec. 105.8 thru Sec. 105.8.2 and substitute the following:

105.8 Construction Stakes, Lines and Grades. The Engineer will set initial field control consisting of bench marks and control monuments.

105.8.1 The Contractor shall be responsible for the preservation of all bench marks and control monuments, and if any of these bench marks or control monuments are

carelessly or willfully destroyed or disturbed, the cost of replacing them may be charged to the Contractor.

105.8.2 These bench marks and control monuments will constitute the initial field control by and in accordance with which the Contractor shall establish all other necessary controls and perform the work in the correct position to correspond to the information shown on the plans and given by the Engineer during the progress of the work. Elevations shown on the drawings and referred to in the specifications are based on the bench marks shown.

105.8.3 The Contractor shall employ competent personnel for making position, gradient and alignment determinations and measurements.

Delete Sec. 105.10.2 and substitute the following:

105.10.2 Inspections and job control tests will generally be made by the Engineer on the following items of work. It shall be the responsibility of the Contractor to notify the Engineer by 1:00 P.M. of the day preceding any operation which affects these items.

- Initial Layout
- Removal of Existing Structure
- Pile Driving
- Footing Excavation
- Reinforcing Steel Placement
- All Concrete Operations
- All Asphalt Operations
- Girder Erection
- Requests for Compaction Testing
- All Base Rock Operations
- All Earthwork Operations
- All Roadway Surfacing Operations
- Post-Tensioning Material Placement
- Post-Tensioning Stressing
- Cutting of Tendon Ends
- Grouting of Stressing Pockets

If any operation which affects the above mentioned items is to be performed on a Monday, notification must be made to the Engineer by 1:00 P.M. of the preceding Friday. The lack of supervision or inspection by the Engineer shall not relieve the Contractor of the responsibility to construct the project according to the plans and specifications. Any work performed or materials used without authorization by the Engineer may be ordered removed and replaced at the Contractor's expense.

Delete Sec. 105.11.2 and substitute the following:

105.11.2 All changes in the work or departures from the plans, will be considered unauthorized, and the Engineer may order such work removed and replaced at the expense of the Contractor unless, before proceeding with the work, the Contractor has a

copy of an Order Record signed by the Engineer, or a Change Order signed by all parties whose signatures are provided for, except the Federal Engineer. These forms will contain complete detailed instructions regarding the proposed changes. Any departure from the instructions contained in such written order shall be considered unauthorized.

Delete Sec. 105.11.3 and substitute the following:

105.11.3 All construction and materials which have been rejected or declared unsatisfactory shall be remedied or removed and replaced in an acceptable manner by the Contractor at his expense. All expense incurred by the Engineer due to corrections or removal and replacement of construction and materials shall be born by the Contractor, and will be deducted from any payment which is or may become due the Contractor. Upon failure of the Contractor to remedy or remove and properly dispose of rejected materials or work, or to replace them immediately after receiving written notice from the Engineer, the Engineer may employ labor to rectify the work, and the cost of rectification will be deducted from any payment due or which may become due the Contractor.

Delete Sec. 105.16.5 and Sec. 105.16.6 and substitute the following:

105.16.6 If the claim is against the Owner, the notice of claim shall be personally delivered or sent by certified mail to the Owner. If the claim is against the Contractor, the notice of the claim will be personally delivered or sent by certified mail to the Contractor at the address shown under the signature on the proposal. If the claim is against an assignee, notice of the claim will be personally delivered or sent by certified mail to the assignee at the address shown on the accepted notice of assignment. The party against whom a claim is filed shall file any counter claims within sixty (60) days after receipt of such notice. All notices of claims shall contain an itemized statement showing completely and fully the items and amounts forming the basis of the claim.

SECTION 106 - CONTROL OF MATERIAL

Add Sec. 106.1.4.1:

106.1.4.1 Unless otherwise specified, all materials shall be subject to visual inspection and job control tests, as determined by the Engineer, and shall be certified by the material supplier that the material supplied conforms to the requirements of these specifications. All certifications shall make reference to the specific project, and shall contain the supplier's name and address.

Delete Sec. 106.2.2 and substitute the following:

106.2.2 Contractor Furnished Sources. If sources of material are not designated in the plans or described in the contrast, or if the Contractor desires to use material from sources other than those designated, the Contractor shall acquire the necessary rights to take materials from the sources and shall pay all costs related thereto, including any which may result from testing of samples by an approved laboratory as required by the Engineer and for an increase in length of haul. All costs of exploring, meeting environmental requirements and developing such other sources shall be borne by the Contractor. The

use of material from other than designated sources which have not had prior approval of the Engineer shall be used at the Contractor's risk and may be considered as unacceptable and unauthorized and, if so considered, will not be paid for. Where practicable, borrow areas, gravel pits, and quarry sites shall be located so that they will not be plainly visible from the state highway or county road.

Delete Sec. 106.3 and substitute the following:

106.3 Samples, Tests, and Cited Specifications. The Contractor shall submit certifications and substantiating test reports, furnished by the supplier or fabricator, certifying that material and manufacturing procedures conform to the specifications. There shall be no direct charge to the Owner for materials taken as samples, either for field tests or for laboratory tests. If a specification of a recognized national standard agency (ASTM, AASHTO, AWWA, AWS, etc.) is designated, the material may, unless otherwise specified, meet either the designated specification or the latest revision thereof in effect at the time of letting of the contract. Unless otherwise specified, all sampling and testing required by the specifications shall be performed by the supplier or fabricator at no cost to the Owner in accordance with the methods specified in the contract or in accordance with the latest methods in effect at the time of letting of the contract, as prescribed by the national standard agency, and the results shall be signed, sealed and stamped according to laws related to professional Engineers. If appropriate methods have not been so prescribed, tests shall be performed in a manner determined by the Engineer.

Delete Sec. 106.8 and substitute the following:

106.8 Material Furnished by the Owner. If any material is to be furnished by the Owner, special provisions designating such materials and their locations will be included in the proposal. The cost of handling and placing all materials shall be considered as included in the contract price for the item in connection with which they are used. The Contractor will be responsible for all material provided to him, and deductions will be made from any monies due him to make good any shortages and deficiencies, from any cause whatsoever, and for any damage which may occur, and for any demurrage charges.

SECTION 107 – LEGAL RELATIONS AND RESPONSIBILITY TO THE PUBLIC

Delete Sec. 107.13 and substitute the following:

107.13 Insurance Requirements. The Contractor shall procure and maintain at its own expense, until acceptance by the Engineer, liability insurance for all damages and losses imposed by law and assumed under the contract, of the kinds and in the amounts specified in Secs 107.13.1 through 107.13.3. Before the Contractor commences the work, the Contractor shall require the insurance company or companies to furnish to the Engineer evidence of such insurance showing compliance with these specifications. All insurance required in Sec 107.13 shall be occurrence policies in a form acceptable to the Engineer, and shall remain in form until all work required to be performed under the terms of the contract is satisfactorily completed as evidenced by its formal acceptance by the Engineer. Each policy or its declaration pages shall provide that the policy shall not materially changed or canceled until the Engineer has been given at least 30 days

advance notice in writing. If any policy is canceled before the contract work is complete, a satisfactory replacement policy must be in force, with notice and evidence of insurance submitted to the Engineer, prior to the effective date of cancellation of the former policy. All evidence of insurance and notices shall be submitted to the Engineer. Upon request, the Contractor shall promptly furnish the Engineer with a complete copy of the policy. Failure to furnish evidence of proper insurance, or complete insurance policies when requested, will result in the temporary suspension of work as provided in Sec 108.6, and may result in order claims or actions for breach of contract or otherwise, as may be recognized at law or in equity.

Delete Sec. 107.13.2.3 and substitute the following:

107.13.2.3 Additional Insureds. Each policy of commercial general liability insurance shall name the Owner, Engineer and its members, agents and employees as additional insureds. Each commercial general liability insurance policy shall also contain a separation of insured conditions. The insurance afforded by the Contractor shall be primary insurance.

Delete Sec. 107.15 and substitute the following:

107.15 Personal Liability of Public Officials. There shall be no personal liability upon the public officials, or any member, employee or agent of the Owner in carrying out any of the provisions of the contract or in exercising any power or authority granted to them, it being understood that in such matters they acted as agents and representatives of the Owner with official and public duty doctrine immunity. If any provision of the contract appears to impose a duty on such an individual, the duty remains exclusively that of the Owner and is not a personal duty or obligation of the individual.

SECTION 108 - PROSECUTION AND PROGRESS

Delete Sec. 108.1.1 and substitute the following:

108.1.1 The Contractor shall not sublet, sell, transfer, assign, or otherwise dispose of the contract or contracts or any portion thereof, or of his right, title, or interest therein, without written consent of the Engineer. Requests for permission to sublet, assign, or otherwise dispose of any portion of the contract shall be in writing and shall be accompanied by evidence that the organization which will perform the work is particularly experienced and equipped for such work. In case such consent is given, the Contractor will be permitted to sublet a portion thereof, but shall perform with his own organization work amounting to not less than forty percent (40%) of the total contract cost, except that any items designated by the Engineer as specialty items may be performed by subcontract and the contract value of any such specialty items so performed by subcontract may be deducted from the total contract cost before computing the amount of work required to be performed by the Contractor with his own organization. The subcontractor shall not sublet, sell, transfer, assign, or otherwise dispose of the subcontract. Consent to a subcontract shall constitute the Owner's endorsement of the qualifications of the subcontractor.

Delete Sec. 108.4 and substitute the following:

108.4 Progress Schedules. The Contractor shall, if requested by the Engineer, submit a progress schedule for review and approval. The progress schedule shall be submitted to the Engineer within three (3) days of the receipt of the request. The progress schedule shall be used to establish the construction operations and to monitor the progress of the work although the Engineer's determination of the then major operation or controlling item of work shall always prevail. The progress schedule shall be in the form specified in Sec 108.4.1, unless the contract contains a different requirement. The progress schedule shall be based on the number of working days, calendar days or other increments as set forth in the contract that the Contractor expects to require in completing the project recognizing the capabilities of labor, equipment, arrangements for materials, mobilization, shop drawing preparation and approvals, and other relevant items.

Delete Sec. 108.4.2 and substitute the following:

108.4.2 Preparation of Initial Schedule. The Contractor shall, if requested by the Engineer, complete development of the initial activities schedule chart and written narrative and present a copy to the Engineer at least seven (7) days prior to the pre-construction conference.

Delete Sec. 108.7.2.2 and substitute the following:

108.7.2.2 The count of working days will start on the date the Contractor starts construction operations, or the authorization date in the Notice to Proceed, whichever is earlier. The Engineer will be the judge of the number of working days to be charged under the contract. In computing the working days charged against the Contractor in the execution of the work, allowance will be made for days that are not working days and for days during which work is suspended with the written approval of the Engineer. The Engineer may make allowance for working days lost due to causes he deems justified for the elimination of the count of working days. No allowance will be made for delay or suspension of the prosecution of the work due to fault of the Contractor. On or about the first of each month, the Engineer will give the Contractor written notice of the number of working days charged to the contract for the preceding time period. Any objection by the Contractor to the number of working days so charged shall be made in writing within five (5) days, setting forth his objections and specifying the reasons therefore, or those objections shall be forever waived and may not constitute the basis for an excusable or compensable delay.

SECTION 109 - MEASUREMENT AND PAYMENT

Delete Sec. 109.1 and substitute the following:

109.1 Measurement of Quantities. Unless otherwise specified hereinafter, all work performed under the contract will be paid for on contract quantity basis as set forth in these specifications. When the quantity of any item that is to be paid for on a contract quantity basis is found to include errors, or when an authorized revision of the plan is made, the quantity will be corrected before making final payment. The method of

measurement and computations to be used in determination of quantities of material furnished and of work performed under the contract will be those methods generally recognized as conforming to good engineering practice.

Add Sec. 109.5.9:

109.5.9 The Contractor shall not begin any work for which price payments are not provided in the contract without first bringing the matter to the attention of the Engineer, and no bills or charges for extra or force account work will be allowed except for that ordered in writing and approved by the Engineer.

Delete Sec 109.6 and substitute the following:

109.6 Method of Payment. Payment to the Contractor for furnishing all material and performing all work under the contract shall be made by check.

Delete Sec. 109.7 in its entirety and substitute the following:

109.7 Partial Payments

109.7.1 The engineer will make semi-monthly payment estimates in writing for the material in place and the work performed during the semi-monthly interval and the value thereof at the contract bid prices. For partially complete items, the proper percentage with relation to completion will be allowed.

109.7.2 The contractor may request in any payment estimate that the engineer include the value of any non-perishable material that will be finally incorporated in the completed work. The engineer shall make the final decision whether to allow a partial payment. Provisions shall be in accordance with Sec. 109.7.2 of the *Missouri Standard Specifications for Highway Construction*.

109.7.3 From the total amount of work items of each estimate, there will be deducted one (1) percent. The retained percentage will be released as provided in Sec. 109.9. The net amount due on the estimate will be certified to the Owner for payment.

109.7.4 Payment may be withheld or nullified in whole or part to such extent as may be necessary to protect the Owner from loss on account of:

- a. Failure to properly submit material certifications and substantiating test reports required under Sec. 106.1.4.1 and Sec. 106.3.
- b. Failure to properly submit certified copies of labor payrolls required under Sec. 110.
- c. Defective work not remedied.
- d. Failure of the Contractor to properly make payment to suppliers or subcontractors for material and/or labor (RSMo 34.057)

- e. A reasonable doubt that the contract can be completed for the balance then unpaid.
- f. Damage to another Contractor.

Delete Sec. 109.9.1 and substitute the following:

109.9.1 Withholding of Retained Percentage Prior to any release of retained percentage, the Contractor shall file with the Owner the following:

- a. An affidavit, to the effect that all payments have been made and all claims have been released for all materials, labor, and other items covered by the contract bond;
- b. Written consent of the surety to such payment;
- c. Certification regarding work performed by and payments made to Disadvantaged Business Enterprises (DBE's);
- d. Lien Waivers signed by each supplier furnishing materials to the project and/or each subcontractor providing services/materials for the project releasing all claims to said materials and services;
- e. The Contractor and all subcontractors shall file an affidavit stating that each has fully complied with the provisions and requirements of the Prevailing Wage Law;
- f. Any other documents which may be required by the contract, or the Engineer.

Add Sec. 109.9.1.3:

109.9.1.3 When the work has been completed and certified by the Owner, a final estimate will be executed and submitted, which will provide payment to the Contractor for the entire sum due him as set forth in these specifications, including the amount previously retained by the Owner. All prior partial estimates and payments shall be subject to correction by the Owner in this final estimate and payment.

SECTION 110 - STATE AND FEDERAL WAGE RATES AND OTHER REQUIREMENTS

Add Sec. 110.5:

110.5 The Contractor and all subcontractors shall maintain books, accounts, ledgers, invoices, drafts, documents, pages and other business records pertaining to the performance of the contract with such materials available at the Contractor's field or permanent business offices at all reasonable times during the performance of the contract and for four (4) years from the date of final payment under the contract, for inspection by authorized representatives.

Add Sec. 110.6:

110.6 The Contractor and each subcontractor shall be required to submit to the Engineer one certified copy of labor payrolls and a weekly statement of compliance (Form WH-347) for each week that work is in progress, within seven (7) days of the payment date of the payroll. If work is temporarily suspended, the last payroll shall be marked appropriately to note that it will be the last payroll until work is resumed.

Add Sec. 110.7:

110.7 Payrolls to be submitted shall be checked for compliance with the contract requirements and will be retained by the Owner for a period of three (3) years following final audit, during which time they will be open to inspection.

Add Sec. 110.8:

110.8 The Contractor shall be responsible for the submittal of payrolls and certifications for all subcontractors.

Add Sec. 110.9:

110.9 The Owner may check payrolls with the following checks, however, it will still be the Contractor's responsibility to ensure proper labor compliance:

- a. The employee's full name as shown on his social security card, his address and social security number shall be entered on each payroll.
- b. Check the payroll for correct employee classification.
- c. Check the payroll for correct hourly wage and, if applicable, the correct overtime hourly rate.
- d. Check the daily and weekly hours worked in each classification including actual overtime hours worked. (Not adjusted hours)
- e. All deductions are listed in the net wage shown. The Form WH-347 is to be used if fringe benefits are paid into established programs. However, if fringe benefits are paid in cash to the employee, the amount shall be indicated on the payroll.
- f. To assure that the payrolls are arithmetically correct, approximately ten percent (10%) of the extensions on the first three (3) payrolls shall be checked. The Contractor will be advised of any violations noted on the labor payroll. All the errors will be corrected by means of a supplementary payroll.
- g. All checking by the Owner will be made in red pencil and initialed by the checker.

- h. Final payroll will be marked "Final" or "Last Payroll".
- i. A record of all payrolls will be maintained by the Owner.

Add Sec. 110.10:

110.10 The contracts for construction projects require that certain applicable information be displayed in a conspicuous place within the project limits for the duration of the contract. The following is a list of required information to be posted both on the project and in the Owner's office:

- a. In the Owner's office:
 - 1. Missouri Equal Employment Opportunity Notice
 - 2. PR-1022, Title 18, Section 1020, Notice on False Statements
- b. On the Projects:
 - 1. State and Federal Wage Rates Notice
 - 2. Federal Equal Employment Opportunity Notice (English and Spanish version)
 - 3. PR-1022, Title 18, Section 1020, Notice on False Statements
 - 4. Form FHWA-1495, and FHWA-1495A, Wage Rate Information (Post with Federal Wage Rates, if applicable)
 - 5. Contractor's and Subcontractor's EEO Policy Statements and name, address, and telephone number of designated EEO Officers
 - 6. Notice to Labor Unions of Contractor's commitment to EEO (if applicable)
 - 7. Notice requesting referral of minorities by present employees

Add Sec. 110.11:

110.11 The Owner's personnel will generally conduct one wage rate interview on each project every month. Labor interviews are not required on railroad and other utility adjustments. The interviewer will determine the employee's name, the employer's name, the classification of the employee, the actual wage paid, and the posted wage.

TECHNICAL SPECIFICATIONS

The Technical Specifications for this project shall consist of the currently effective version of the *Missouri Standard Specifications for Highway Construction*, Sections 201-1092 except as modified or contradicted by the County's Contract, Job Special Provisions, General Provisions and Plans.

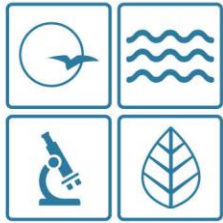

MISSOURI
DEPARTMENT OF
NATURAL RESOURCES

Michael L. Parson
Governor

Dru Buntin
Director

July 8, 2022

Andy Myers
Cole County Public Works
5055 Monticello Road
Jefferson City, MO 65101

Dear Permittee:

Pursuant to the Federal Water Pollution Control Act, under the authority granted to the State of Missouri and in compliance with the Missouri Clean Water Law, we have issued and are enclosing your Missouri State Operating Permit for Cole County, MOR-100034.

Please read and review your permit and attached Standard Conditions. They contain important information on site management and reporting requirements. Quarterly reports required by this report must be submitted through our Electronic Discharge Monitoring Report (eDMR) Submission System.

This permit may include requirements with which you may not be familiar. If you would like the Missouri Department of Natural Resources to meet with you to discuss how to satisfy the permit requirements, an appointment can be set up by contacting the permit writer at 573-526-1139. These visits are called Compliance Assistance Visits and focus on explaining the requirements to the permit holder.

This permit is both your Federal NPDES Permit and your new Missouri State Operating Permit and replaces all previous State Operating Permits issued for this facility under this permit number. In all future correspondence regarding this facility, please refer to your State Operating Permit number and facility name as shown on page one of the permit.

If you were adversely affected by this decision, you may be entitled to an appeal before the Administrative Hearing Commission (AHC) pursuant to 10 CSR 20-1.020 and 10 CSR 20-6.020; RSMo Section 621.250, 640.013, and 644.051.6. To appeal, you must file a petition with the AHC within thirty days after the date this decision was mailed or the date it was delivered, whichever date was earlier. If any such petition is sent by registered mail or certified mail, it will be deemed filed on the date it is mailed; if it is sent by any method other than registered mail or certified mail, it will be deemed filed on the date it is received by the AHC. Contact information for the AHC is: Administrative Hearing Commission, Truman State Office Building, Room 640, 301 W. High Street, P.O. Box 1557, Jefferson City, MO 65102, phone: 573-751-2422, fax: 573-751-5018; website: <http://ahc.mo.gov/>.



Andy Myers
Page 2

Please be aware that this facility may also be subject to any applicable county or other local ordinances or restrictions. If you have any questions concerning this permit, please do not hesitate to contact the Water Protection Program at P.O. Box 176, Jefferson City, MO 65102, 573-522-4502.

Sincerely,

WATER PROTECTION PROGRAM

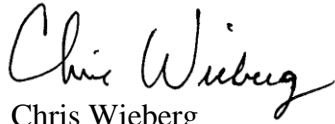
A handwritten signature in black ink that reads "Chris Wieberg". The signature is written in a cursive style with a large initial "C" and a long, sweeping underline.

Chris Wieberg
Director

CW:vs

Enclosure

STATE OF MISSOURI
DEPARTMENT OF NATURAL RESOURCES
MISSOURI CLEAN WATER COMMISSION



MISSOURI STATE OPERATING PERMIT

General Operating Permit

In compliance with the Missouri Clean Water Law, (Chapter 644 R.S. Mo as amended, hereinafter, the Law), and the Federal Water Pollution Control Act (Public Law 92-500, 92nd Congress) as amended,

Permit No MOR100034

Owner: Cole County
Address: 301 E High Street
Room 200
Jefferson City, MO 65109

Continuing Authority: Cole County Road and Bridge Department
5055 Monticello Rd.
Jefferson City, MO 65109

Facility Name: Cole County Public Works
Facility Address: 5055 Monticello Rd
JEFFERSON CITY, MO 65109

Legal Description: Sec. 04, T43N, R12W, Cole County
UTM Coordinates: 565135.257/4262453.883
Receiving Stream: Tributary to Moreau R. (U)
First Classified Stream - ID#: 100K Extent-Remaining Streams (C) 3960.00
USGS# and Sub Watershed#: 10300102 - 1206

is authorized to discharge from the facility described herein, in accordance with the effluent limitations and monitoring requirements as set forth herein.

FACILITY DESCRIPTION All Outfalls SIC #1629

All Outfalls - Construction or land disturbance activity (e.g., clearing, grubbing, excavating, grading, filling and other activity that results in the destruction of the root zone and/or land disturbance activity that is reasonably certain to cause pollution of waters of the state)

Issued to a city, county, state or federal agency, other governmental jurisdiction, or other private area-wide projects as determined by the Department on a case-by-case basis

This permit authorizes only wastewater, including storm water, discharges under the Missouri Clean Water Law and the National Pollutant Discharge Elimination System, it does not apply to other regulated areas. This permit may be appealed in accordance with RSMo Section 644.051.6 and 621.250, 10 CSR 20-6.020, and 10 CSR 20-1.020.

July 05, 2022

Issue Date

Chris Wieberg, Director
Water Protection Program

July 04, 2027

Expiration Date

I. APPLICABILITY

A. Permit Coverage and Authorized Discharges

1. This Missouri State Operating Permit (permit) authorizes the discharge of stormwater and certain non-stormwater discharges from land disturbance sites that disturb one or more acres, or disturb less than one acre when part of a larger common plan of development or sale that will disturb a cumulative total of one or more acres over the life of the project.

A Missouri State Operating Permit must be issued before any site vegetation is removed or the site disturbed. Any site owner/operator subject to these requirements for stormwater discharges and who disturbs land prior to permit issuance from the Missouri Department of Natural Resources (Department) is in violation of both State regulations per 10 CSR 20-6.200(1)(A) and Federal regulations per 40 CFR 122.26. The owner/operator of this permit is responsible for compliance with this permit [10 CSR 20-6.200 (3)(B)].

2. This general permit is issued to a city, county, state or federal agency, other governmental jurisdiction, or other private area-wide projects as determined by the Department on a case-by-case basis, for land disturbance projects performed by or under contract to the permittee.
3. This permit authorizes stormwater discharges from land disturbance support activities (e.g., equipment staging yards, material storage areas, excavated material disposal areas, borrow areas, concrete, or asphalt batch plants) provided appropriate stormwater controls are designed, installed, and maintained and the following conditions are met and addressed in the Stormwater Pollution Prevention Plan (SWPPP). The permittee is responsible for compliance with this permit for any stormwater discharges from construction support activity.
 - (a) The support activity is directly related to the construction site required to have permit coverage for stormwater discharges;
 - (b) The support activity is not a commercial operation or serve multiple unrelated construction sites;
 - (c) The support activity does not continue to operate beyond the completion of the construction activity at the project it supports;
 - (d) Sediment and erosion controls are implemented in accordance with the conditions of this permit; and
 - (e) The support activity is strictly stormwater discharges or non-stormwater discharges listed in PART I, APPLICABILITY, Condition A.4. Support activities which discharge process water shall apply for separate coverage (e.g., a concrete batch plant discharging process water shall be covered under a MOG49).
4. This permit authorizes non-stormwater discharges associated with your construction activity from the following activities provided that these discharges are treated by appropriate Best Management Practices (BMPs) where applicable and addressed in the permittee's site specific SWPPP required by this general permit:
 - (a) Discharges from emergency fire-fighting activities;
 - (b) Hydrant flushing and water line flushing, provided the discharged water is managed to avoid instream water quality impacts;
 - (c) Landscape watering, including to establish vegetation;
 - (d) Water used to control dust;
 - (e) Waters used to rinse vehicles and equipment, provided there is no discharge of soaps, solvents, or detergents used for such purposes;
 - (f) External building washdown, provided soaps, solvents, and detergents are not used, and external surfaces do not contain hazardous substances (e.g., paint or caulk containing polychlorinated biphenyls (PCBs))
 - (g) Pavement wash waters, provided spills or leaks of toxic or hazardous substances have not occurred (unless all spill material has been removed) and where soaps, solvents, and detergents are not used. Directing pavement wash waters directly into any water of the state, storm drain inlet, or stormwater conveyance (constructed or natural site drainage features), unless the conveyance is connected to an effective control, is prohibited;
 - (h) Uncontaminated air conditioning or compressor condensate;
 - (i) Uncontaminated, non-turbid discharges of ground water or spring water;
 - (j) Foundation or footing drains where flows are not contaminated with process materials; and
 - (k) Uncontaminated construction dewatering water discharged in accordance with requirements found in this permit for specific dewatering activities.

B. Permit Restrictions and Limitations

1. This permit does not authorize the discharge of process wastewaters, treated or otherwise.
2. For sites operating within the watershed of any Outstanding National Resource Water (which includes the Ozark National Riverways and the National Wild and Scenic Rivers System), sites that discharge to an Outstanding State Resource Water, or facilities located within the watershed of an impaired water as designated in the Clean Water Act (CWA) Section 303(d) list with an impairment for sedimentation/siltation:
 - (a) This permit authorizes stormwater discharge provided no degradation of water quality occurs due to discharges from the permitted facility per 10 CSR 20-7.031(3)(C).
 - (b) A site with a discharge found to be causing degradation or contributing to an impairment by discharging a pollutant of concern, during an inspection or through complaint investigations, may be required to become a no discharge facility or obtain a site-specific permit with more stringent monitoring and SWPPP requirements.
3. This permit does not allow placement of fill material into any stream or wetland, alteration of a stream channel, or obstruction of stream flow unless the appropriate CWA Section 404 permitting authority provides approval for such actions or determines such actions are exempt from Section 404 jurisdiction. Additionally, this permit does not authorize placement of fill in floodplains unless approved or determined exempt by appropriate federal and/or state floodplain development authorities.
4. This operating permit does not affect, remove, or replace any requirement of the National Environmental Policy Act; the Endangered Species Act; the National Historic Preservation Act; the Comprehensive Environmental Response, Compensation and Liability Act; the Resource Conservation and Recovery Act; or any other relevant acts. Determination of applicability to the above mentioned acts is the responsibility of the permittee. Additionally, this permit does not establish terms and conditions for runoff resulting from silvicultural activities listed in Section 402(1)(3)(a) of the Clean Water Act.
5. Compliance with all requirements in this permit does not supersede any requirement for obtaining project approval from an established local authority nor remove liability for compliance with county and other local ordinances.
6. The Department may require any facility or site authorized by a general permit to apply for a site-specific permit [10 CSR 20-6.010(13)(C)].
7. If a facility or site covered under a current general permit desires to apply for a site-specific permit, the facility or site may do so by contacting the Department for application requirements and procedures.
8. Any discharges not expressly authorized in this permit and not clearly disclosed in the permit application cannot become authorized or shielded from liability under CWA section 402(k) or Section 644.051.16, RSMo, by disclosure to EPA, state, or local authorities after issuance of this permit via any means, including any other permit applications, funding applications, the SWPPP, discharge monitoring reporting, or during an inspection. Discharges at the facility not expressly authorized by this permit must be covered by another permit, be exempt from permitting, or be authorized through some other method.

II. EXEMPTIONS FROM PERMIT REQUIREMENTS

1. Sites that discharge all stormwater runoff directly to a combined sewer system (as defined in 40 CFR 122.26 and 40 CFR 35.2005) connecting to a publicly owned treatment works which has consented to receive such a discharge are exempt from Department stormwater permit requirements.
2. Land disturbance activities that disturb less than one (1) acre of total land area which are not part of a common plan or sale where water quality standards are not exceeded are exempt from Department stormwater permit requirements.

3. Oil and gas related activities as listed in 40 CFR 122.26(a)(2)(ii) where water quality standards are not exceeded are exempt from Department stormwater permit requirements.
4. Linear, strip, or ribbon construction or maintenance operations meeting one (1) of the following criteria are exempt from Department stormwater permit requirements:
 - (a) Grading of existing dirt or gravel roads which does not increase the runoff coefficient and the addition of an impermeable surface over an existing dirt or gravel road;
 - (b) Cleaning or routine maintenance of roadside ditches, sewers, waterlines, pipelines, utility lines, or similar facilities;
 - (c) Trenches two (2) feet in width or less; or
 - (d) Emergency repair or replacement of existing facilities as long as BMPs are employed during the emergency repair.

III. REQUIREMENTS

1. The permittee shall post a public notification sign at the main entrance to the site, or a publically visible location, with the specific MOR100 permit number. The public notification sign must be visible from the public road that provides access to the site's main entrance. An alternate location is acceptable provided the public can see it and it is noted in the SWPPP. The public notification sign must remain posted at the site until the site is finalized.
2. The permittee shall be responsible for notifying the land owner and each contractor or entity (including utility crews and city employees or their agents) who will perform work at the site of the existence of the SWPPP and what actions or precautions shall be taken while on site to minimize the potential for erosion and the potential for damaging any BMP. The permittee is responsible for any damage a subcontractor may do to established BMPs and any subsequent water quality violation resulting from the damage.
3. Ensure the design, installation, and maintenance of effective erosion and sediment controls to minimize the discharge of pollutants. At a minimum, such controls must be designed, installed, and maintained to:
 - (a) Control stormwater volume, velocity, and peak flow rates to minimize soil erosion;
 - (b) Control stormwater discharges, including both peak flow rates and total stormwater volume, to minimize erosion at outlets and to minimize downstream channel and stream bank erosion and scour;
 - (c) Minimize the amount of exposed soil during construction activity;
 - (d) Minimize the disturbance of steep slopes;
 - (e) Minimize sediment discharges from the site. Address factors such as:
 - 1) The amount, frequency, intensity, and duration of precipitation;
 - 2) The nature of resulting stormwater runoff;
 - 3) Expected flow from impervious surfaces, slopes, and drainage features; and
 - 4) Soil characteristics, including the range of soil particle size expected to be present on the site.
 - (f) Provide and maintain natural buffers around surface waters as detailed in Part V. BMP REQUIREMENTS Condition 7, direct stormwater to vegetated areas to increase sediment removal and maximize stormwater infiltration and filtering, unless infeasible; and
 - (g) Minimize soil compaction and preserve topsoil where practicable.

A 2-year, 24-hour storm event can be determined for the project location using the National Oceanic and Atmospheric Administration's National Weather Service Atlas 14 which can be located at https://hdsc.nws.noaa.gov/hdsc/pfds/pfds_map_cont.html, or the permittee can determine local rainfall distribution for a 2-year, 24 hours storm event using multi-decade local high density rain gauge data, as approved by the Department.

4. BMPs for land disturbance [10 CSR 20-6.200(1)(D)2] are a schedule of activities, practices, or procedures that reduces the amount of soil available for transport or a device that reduces the amount of suspended solids in runoff before discharge to waters of the state. The term BMPs are also used to describe the sediment and erosion controls and other activities used to prevent stormwater pollution. BMPs are divided into two main categories: structural or non-structural; and they are also classified as temporary or permanent. Temporary BMPs may be added and removed as necessary with updates to the SWPPP as specified in the requirements below.

5. Installation of BMPs necessary to prevent soil erosion and sedimentation at the downgradient project boundary (e.g. buffers, perimeter controls, exit point controls, storm drain inlet protection) must be complete prior to the start of all phases of construction. By the time construction activity in any given portion of the site begins, downgradient BMPs must be installed and operational to control discharges from the initial site clearing, grading, excavating, and other earth-disturbing activities. Additional BMPs shall be installed as necessary throughout the life of the project.
6. All BMPs shall be maintained and remain in effective operating condition during the entire duration of the project, with repairs made within the timeframes specified elsewhere in this permit, until final stabilization has been achieved.
 - (a) Ensure BMPs are protected from activities that would reduce their effectiveness.
 - (b) Remove any sediment per the BMP manufacturer's instructions or before it has accumulated to one-half of the above-ground height of any BMP that collects sediment (i.e., silt fences, sediment traps, etc.)
 - (c) The project is considered to achieve final stabilization when Part V. BMP REQUIREMENTS, Condition 13 is met.
7. Minimize sediment trackout from the site and sediment transport onto roadways.
 - (a) Restrict vehicle traffic to designated exit points.
 - (b) Use appropriate stabilization techniques or BMPs at all points that exit onto paved roads or areas outside of the site.
 - (c) Use additional controls or BMPs to remove sediment from vehicle and equipment tires prior to exit from facility where necessary.
 - (d) Any sediment or debris that is tracked out past the exit pad or is deposited on a roadway after a precipitation event shall be removed by the shorter of either the same business day (for business days only), or by the end of the next business day if track-out occurs on a non-business day, and before predicted rain events. Remove the track-out sediment by sweeping, shoveling, or vacuuming these surfaces, or by using other similarly effective means of sediment removal. Sediment or debris tracked out on pavement or other impervious surfaces shall not be disposed of into any stormwater conveyance, storm drain inlet, or water of the state.
 - (e) Stormwater inlets susceptible to receiving sediment or other pollutants from the permitted land disturbance site shall have curb inlet protection. This may include inlets off the active area where track out from vehicles and equipment could impact the stormwater runoff to those inlets.
8. Concrete washout facilities shall be used to contain concrete waste from the activities onsite, unless the washout of trucks and equipment is managed properly at an off-site location. The washout facility shall be managed to prevent solid and/or liquid waste from entering waters of the state by the following:
 - (a) Direct the wash water into leak-proof containers or pits designed so that no overflows can occur due to inadequate sizing or precipitation;
 - (b) Locate washout activities away from waters of the state, stormwater inlets, and/or stormwater conveyances where practicable. If not practicable, use BMPs to reduce risk of waste leaving the washout facility;
 - (c) Washout facilities shall be cleaned, or new facilities must be constructed and ready for use, once the washout is 75% full;
 - (d) Designate the washout area(s) and conduct such activities only in these areas.
 - (e) Ensure contractors are aware of the location, such as by marking the area(s) on the map or signage visible to the truck and/or equipment operators.
9. Good housekeeping practices shall be maintained at all times to keep waste from entering waters of the state.
 - (a) Provide solid and hazardous waste management practices, including providing trash containers, regular site cleanup for proper disposal of solid waste such as scrap building material, product/material shipping waste, food/beverage containers, spent structural BMPs;
 - (b) Provide containers and methods for proper disposal of waste paints, solvents, and cleaning compounds.
 - (c) Manage sanitary waste. Portable toilets shall be positioned so that they are secure and will not be tipped or knocked over and so that they are located away from waters of the state and stormwater inlets and stormwater conveyances.
 - (d) Ensure the storage of construction materials be kept away from drainage courses, stormwater conveyances, storm drain inlets, and low areas.

10. All fueling facilities present shall at all times adhere to applicable federal and state regulations concerning underground storage, above ground storage, and dispensers.
11. Any hazardous wastes that are generated onsite shall be managed, stored, and transported according to the provisions of the Missouri Hazardous Waste Laws and Regulations.
12. Store all paints, solvents, petroleum products, petroleum waste products, and storage containers (such as drums, cans, or cartons) so they are not exposed to stormwater or provide other prescribed BMPs (such as plastic lids and/or portable spill pans) to prevent the commingling of stormwater with container contents. Commingled water may not be discharged under this permit. Provide spill prevention, control, and countermeasures to contain the spill. Any containment system used to implement this requirement shall be constructed of materials compatible with the substances contained and shall prevent the contamination of groundwater.
13. Implement measures intended to prevent the spillage or loss of fluids, oil, grease, fuel, etc. from vehicles and equipment to thereby prevent the contamination of stormwater from these substances. This may include prevention measures such as, but not limited to, utilizing drip pans under vehicles and equipment stored outdoors, covering fueling areas, using dry clean-up methods, use of absorbents, and cleaning pavement surfaces to remove oil and grease.
14. Spills, Overflows, and Other Unauthorized Discharges.
 - (a) Any spill, overflow, or other discharge not specifically authorized in the permit above are unauthorized.
 - (b) Should an unauthorized discharge cause or permit any contaminants, other than sediment, or hazardous substance to discharge or enter waters of the state, the unauthorized discharge must be reported to the regional office as soon as practicable but no more than 24 hours after the discovery of the discharge. If the spill or overflow needs to be reported after normal business hours or on the weekend, the facility must call the Department's Environmental Emergency Response hotline at (573) 634-2436. Leaving a message on a Department staff member voice-mail does not satisfy this reporting requirement.
 - (c) A record of all spills shall be retained with the SWPPP and made available to the Department upon request.
 - (d) Other spills not reaching waters of the state must be cleaned up as soon as possible to prevent entrainment in stormwater but are not required to be reported to the Department.
15. The full implementation of this operating permit shall constitute compliance with all applicable federal and state statutes and regulations in accordance with RSMo 644.051.16 and the CWA §402(k); however, this permit may be reopened and modified or alternatively revoked and reissued to comply with any applicable effluent standard or limitation issued or approved under Clean Water Act §§ 301(b)(2)(C) and (D), 304(b)(2), and 307(a)(2) if the effluent standard or limitation so issued or approved contains different conditions or is otherwise more stringent than any effluent limitation in the permit or controls any pollutant not limited in the permit. This permit may be modified, revoked and reissued, or terminated for cause. The filing of a request by the permittee for a permit modification, termination, notice of planned changes, or anticipated non-compliance does not stay any permit condition.

IV. STORMWATER POLLUTION PREVENTION PLAN (SWPPP) MANAGEMENT REQUIREMENTS

1. The primary requirement of this permit is the development and implementation of a SWPPP which incorporates site specific practices to best minimize the soil exposure, soil erosion, and the discharge of pollutants, including solids for each site covered under this permit.

The purpose of the SWPPP is to ensure the design, implementation, management, and maintenance of BMPs in order to prevent sediment and other pollutants in stormwater discharges associated with the land disturbance activities [40 CFR 122.44 (k)(4)] from entering waters of the state above established general and narrative criteria; compliance with Missouri Water Quality Standards; and compliance with the terms and conditions of this general permit.

- (a) **The SWPPP must be developed and implemented prior to conducting any land disturbance activities and must be specific to the land disturbance activities at the site.**
- (b) The permittee shall fully implement the provisions of the SWPPP required under this permit as a condition of this general permit throughout the term of the land disturbance project. Failure to develop, implement, and maintain a SWPPP may lead to immediate enforcement action.

- (c) The SWPPP shall be updated any time site conditions warrant adjustments to the project or BMPs.
 - (d) Either an electronic copy or a paper copy of the SWPPP, and any required reports, must be accessible to anyone on site at all times when land disturbance operations are in process or other operational activities that may affect the maintenance or integrity of the BMP structures and made available as specified under Part VIII. STANDARD PERMIT CONDITIONS, Condition 1 of this permit. The SWPPP shall be readily available upon request and should not be sent to the Department unless specifically requested
2. Failure to implement and maintain the BMPs chosen, which can be revised and updated, is a permit violation. The chosen BMPs will be the most reasonable and cost effective while also ensuring the highest quality water discharged attainable for the facility. Facilities with established SWPPPs and BMPs shall evaluate BMPs on a regular basis and change the BMPs as needed if there are BMP deficiencies.
 3. The SWPPP must:
 - (a) List and describe the location of all outfalls;
 - (b) List any allowable non-stormwater discharges occurring on site and where these discharges occur;
 - (c) Incorporate required practices identified below;
 - (d) Incorporate sediment and erosion control practices specific to site conditions;
 - (e) Discuss whether or not a 404 Permit is required for the project; and
 - (f) Name the person(s) responsible for inspection, operation, and maintenance of BMPs. The SWPPP shall list the names and describe the role of all owners/primary operators (such as general contractor, project manager) responsible for environmental or sediment and erosion control at the land disturbance site.
 4. The SWPPP briefly must describe the nature of the land disturbance activity, including:
 - (a) The function of the project (e.g., low density residential, shopping mall, highway, etc.);
 - (b) The intended sequence and timing of activities that disturb the soils at the site; and
 - (c) Estimates of the total area expected to be disturbed by excavation, grading, or other land disturbance support activities including off-site borrow and fill areas;
 5. In order to identify the site, the SWPPP shall include site information including size in acres. The SWPPP shall have sufficient information to be of practical use to contractors and site construction workers to guide the installation and maintenance of BMPs.
 6. The function of the SWPPP and the BMPs listed therein is to prevent or minimize pollution to waters of the state. A deficiency of a BMP means it was not effective in preventing or minimizing pollution of waters of the state.

The permittee shall select, install, use, operate and maintain appropriate BMPs for the permitted site. The following manuals are acceptable resources for the selection of appropriate BMPs.

Developing Your Stormwater Pollution Prevention Plan: A Guide for Construction Sites, (Document number EPA 833-R-06-004) published by the United States Environmental Protection Agency (USEPA) in May 2007. This manual as well as other information, including examples of construction SWPPPs, is available at the USEPA internet site at https://www.epa.gov/sites/production/files/2015-10/documents/sw_swppp_guide.pdf; and <https://www.epa.gov/npdes/developing-stormwater-pollution-prevention-plan-swppp>.

The latest version of *Protecting Water Quality: A field guide to erosion, sediment and stormwater best management practices for development sites in Missouri*, published by the Department. This manual is available at: <https://dnr.mo.gov/document-search/protecting-water-quality-field-guide>.

The permittee is not limited to the use of these guidance manuals. Other guidance publications may be used to select appropriate BMPs. However, all BMPs must be described and justified in the SWPPP. Although the use of these manuals or other resources is recommended and may be used for BMP selection, they do not supersede the conditions of this permit. They may be used to inform in the decision making process for BMP selection but they are not themselves part of the permit conditions.

The permittee may retain the SWPPP, inspection reports, and all other associated documents (including a copy of this permit) electronically pursuant to RSMo 432.255. The documents must be made available to all interested persons in either paper or electronic format as required by this permit and the permittee must remit a copy (electronic or otherwise) of the SWPPP and inspection reports to the Department upon request.

7. The SWPPP must contain a legible site map, multiple maps if necessary, identifying:
 - (a) Site boundaries of the property;
 - (b) Locations of all waters of the state (including wetlands) within the site and half a mile downstream of the site's outfalls;
 - (c) Location of all outfalls;
 - (d) Direction(s) of stormwater flow (use arrows) and approximate slopes before and after grading activities;
 - (e) Areas of soil disturbance and areas that will not be disturbed (or a statement that all areas of the site will be disturbed unless otherwise noted);
 - (f) Location of structural and non-structural BMPs, including natural buffer areas, identified in the SWPPP;
 - (g) Locations where stabilization practices are expected to occur;
 - (h) Locations of on-site and off-site material, waste, borrow, or equipment storage areas and stockpiles;
 - (i) Designated points where vehicles will exit the site;
 - (j) Location of stormwater inlets and conveyances including ditches, pipes, man-made conduits, and swales; and
 - (k) Areas where final stabilization has been achieved.

8. An individual shall be designated by the permittee as the environmental lead. This environmental lead shall have knowledge in erosion, sediment, and stormwater control principles, knowledge of the permit, and the site's SWPPP. The environmental lead shall ensure all personnel and contractors understand any requirements of this permit may be affected by the work they are doing. The environmental lead or designated inspector(s) knowledgeable in erosion, sediment, and stormwater control principles shall inspect all structures that function to prevent or minimize pollution of waters of the state.

9. Throughout coverage under this permit, the permittee shall amend and update the SWPPP as appropriate during the term of the land disturbance activity. All SWPPP modifications shall be signed and dated. The permittee shall amend the SWPPP to incorporate any significant site condition changes which impact the nature and condition of stormwater discharges. At a minimum, these changes include whenever the:
 - (a) Location, design, operation, or maintenance of BMPs is changed;
 - (b) Design of the construction project is changed that could significantly affect the quality of the stormwater discharges;
 - (c) The permittee's inspections indicate deficiencies in the SWPPP or any BMP;
 - (d) Department notifies the permittee in writing of deficiencies in the SWPPP;
 - (e) SWPPP is determined to be ineffective in minimizing or controlling erosion and sedimentation (e.g., there is visual evidence of excessive site erosion or sediment deposits in streams, lakes, or downstream waterways, sediment or other wastes off site); and/or
 - (f) Department determines violations of water quality standards may occur or have occurred.

10. Site Inspections: The environmental lead, or a designated inspector, shall conduct regularly scheduled inspections. These inspections shall be conducted by a qualified person, one who is responsible for environmental matters at the site, or a person trained by and directly supervised by the person responsible for environmental matters at the site. Site inspections shall include, at a minimum, the following:
 - (a) For disturbed areas that have not achieved final stabilization, all installed BMPs and other pollution control measures shall be inspected to ensure they are properly installed, appear to be operational, and are working as intended to minimize the discharge of pollutants.
 - (b) For areas on site that have achieved either temporary or final stabilization, while at the same time active construction continues on other areas, ensure that all stabilization measures are properly installed, appear to be operational, and are working as intended to minimize the discharge of pollutants.
 - (c) Inspect all material, waste, borrow, and equipment storage and maintenance areas that are covered by this permit. Inspect for conditions that could lead to spills, leaks, or other accumulations of pollutants on the site.
 - (d) Inspect all areas where stormwater typically flows within the site, including drainage ways designed to divert, convey, and/or treat stormwater.

- (e) All stormwater outfalls shall be inspected for evidence of erosion, sediment deposition, or impacts to the receiving stream. If a discharge is occurring during an inspection, the inspector must observe and document the visual quality of the discharge and take note of the characteristics of the stormwater discharge, including turbidity, color; odor; floating, settled, or suspended solids; foam; oil sheen; and other indicators of stormwater pollutants.
 - (f) When practicable the receiving stream shall also be inspected for a minimum of 50 feet downstream of the outfall.
 - (g) The perimeter of the site shall be inspected for evidence of BMP failure to ensure concentrated flow does not develop a new outfall.
 - (h) The SWPPP must explain how the environmental lead will be notified when stormwater runoff occurs.
11. Inspection Frequency: All BMPs must be inspected in accordance to one of the schedules listed below. The inspection frequency shall be documented in the SWPPP, and any changes to the frequency of inspections, including switching between the options listed below, must be documented on the inspection form:
- (a) At least once every seven (7) calendar days and within 48 hours after any storm event equal to or greater than a 2-year, 24-hour storm has ceased during a normal work day or within 72 hours if the rain event ceases during a non-work day such as a weekend or holiday; or
 - (b) Once every 14 calendar days and within 24 hours of the occurrence of a storm event of 0.25 inches of precipitation or greater, or the occurrence of runoff from snowmelt. To determine if a storm event of 0.25 inches or greater has occurred on the site, the permittee shall either keep a properly maintained rain gauge on site, or obtain the storm event information from a weather station near the site location.
 - 1) Inspections are only required during the project's normal working hours.
 - 2) An inspection must be conducted within 24 hours of a storm event which has produced 0.25 inches. The inspection shall be conducted within 24 hours of the event end, or within 72 hours if the rain event ceases during a non-work day such as a weekend or holiday.
 - 3) If it is elected to inspect every 14 calendar days and there is a storm event at the site that continues for multiple days, and each day of the storm produces 0.25 inches or more of rain, the permittee shall conduct an inspection within 24 hours of the end of the storm or within 72 hours if the rain event ceases during a non-work day such as a weekend or holiday.
 - (c) Areas on site that have achieved stabilization, while at the same time active construction continues on other areas, may reduce inspection frequency to monthly, for those stabilized areas, if the following conditions exist:
 - 1) For areas where disturbed portions have undergone temporary stabilization, inspections shall occur at least once a month while stabilized and when re-disturbed shall follow either frequency outlined in (a),(b), or (c) above.
 - 2) Areas on site that have achieved final stabilization must be inspected at least once per month until the permit is terminated.
 - (d) If construction activities are suspended due to frozen conditions, the permittee may temporarily reduce site inspections to monthly until thawing conditions begin to occur if all of the following are met:
 - 1) Land disturbances have been suspended; and
 - 2) All disturbed areas of the site have been stabilized in accordance with Part V. BMP REQUIREMENTS, Condition 13.
 - 3) The change shall be noted in the SWPPP.
 - (e) Any basin dewatering shall be inspected daily when discharge is occurring. The discharge shall be observed and dewatering activities shall be ceased immediately if the receiving stream is being impacted. These inspections shall be noted on a log or on the inspection report.

If weather conditions or other issues prevent correction of BMPs within seven calendar days, the reasons for the delay must be documented (including pictures), and there must be a narrative explaining why the work cannot be accomplished within the seven day time period. The documentation must be filed with the regular inspection reports. The corrections shall be made as soon as weather conditions or other issues allow.

12. Site Inspection Reports: A log of each inspection and/or copy of the inspection report shall be kept readily accessible and must be made available upon request by the Department. Electronic logs are acceptable as long as reports can be provided within 24 hours. If inspection reports are kept off site, the SWPPP must indicate where they are stored. The inspection report shall be signed by the environmental lead or designated inspector (electronically or otherwise).
- (a) The inspection report is to include the following minimum information:
 - 1) Inspector's name and title.
 - 2) Date and time of inspection.
 - 3) Observations relative to the effectiveness of the BMPs and stabilization measures. The following must be

documented:

- a. Whether BMPs are installed, operational, and working as intended;
 - b. Whether any new or modified stormwater controls are needed;
 - c. Facilities examined for conditions that could lead to spill or leak;
 - d. Outfalls examined for visual signs of erosion or sedimentation at outfalls. Excessive erosion or sedimentation may be due to BMP failure or insufficiency. Response to observations should be addressed in the inspection report.
- 4) Corrective actions taken or necessary to correct the observed problem.
 - 5) Listing of areas where land disturbance operations have permanently or temporarily stopped.
13. Any structural or maintenance deficiencies for BMPs or stabilization measures shall be documented and corrected as soon as possible but no more than seven (7) calendar days after the inspection.
- (a) Corrective action documentation shall be stored with the associated site inspection report.
 - (b) Immediately take all reasonable steps to address the condition, including cleaning up any contaminated surfaces so the material will not discharge in subsequent storm events.
 - (c) If weather conditions or other issues prevent correction of BMPs within seven calendar days, the reasons for the delay must be documented (this may include pictures) and there must be a narrative explaining why the work cannot be accomplished within the seven day time period. The permittee shall correct the problem as soon as weather conditions or issues allow.
 - (d) Corrective actions may be required by the Department. The permittee must comply with any corrective actions required by the Department as a result of permit violations found during an inspection.

V. BMP REQUIREMENTS

1. The information, practices, and BMP requirements in this section shall be implemented on site and, where noted, provided for in the SWPPP.
2. Existing vegetation and trees shall be preserved where practicable. The permittee is encouraged to preserve topsoil where practicable.
3. The permittee shall select appropriate BMPs for use at the site and list them in the SWPPP. When selecting effective BMPs, the permittee shall consider stormwater volume and velocity. A BMP that has demonstrated ineffectiveness in preventing or minimizing sediment or other pollutants from leaving a given site shall be replaced with a more effective BMP, or additional and sequential BMPs and treatment devices may be incorporated as site conditions allow. The permittee should consider a schedule for performing erosion control measures when selecting BMPs.
4. The SWPPP shall include a description of both structural and non-structural BMPs that will be used at the site.
 - (a) The SWPPP shall provide the following general information for each BMP which will be used one or more times at the site:
 - 1) Physical description of the BMP;
 - 2) Site conditions that must be met for effective use of the BMP;
 - 3) BMP installation/construction procedures, including typical drawings; and
 - 4) Operation and maintenance procedures and schedules for the BMP.
 - (b) The SWPPP shall provide the following information for each specific instance where a BMP is to be installed:
 - 1) Whether the BMP is temporary or permanent;
 - 2) When the BMP will be installed in relation to each phase of the land disturbance procedures to complete the project; and
 - 3) Site conditions that must be met before removal of the BMP if the BMP is not a permanent BMP.
5. Structural BMP Installation: The permittee shall ensure all BMPs are properly installed and operational at the locations and relative times specified in the SWPPP.
 - (a) Perimeter control BMPs for runoff from disturbed areas shall be installed before general site clearing is started. Note this requirement does not apply to earth disturbances related to initial site clearing and establishing entry, exit, or access of the site, which may require that stormwater controls be installed immediately after the earth

disturbance.

- (b) For phased projects, BMPs shall be properly installed as necessary prior to construction activities.
 - (c) Stormwater discharges which leave the site from disturbed areas shall pass through an appropriate impediment to sediment movement such as a sedimentation basin, sediment traps (including vegetative buffers), or silt fences prior to leaving the land disturbance site.
 - (d) A drainage course change shall be clearly marked on a site map and described in the SWPPP.
 - (e) If vegetative stabilization measures are being implemented, stabilization efforts are considered “installed” when all activities necessary to seed or plant the area are completed. Vegetative stabilization is not considered “operational” until the vegetation is established.
6. Install sediment controls along any perimeter areas of the site that are downgradient from any exposed soil or other disturbed areas. Prevent stormwater from circumventing the edge of the perimeter control. For sites where perimeter controls are infeasible, other practices shall be implemented to minimize discharges to perimeter areas of the site.
7. For surface waters of the state, defined in Section 644.016.1(27) RSMo, located on or adjacent to the site, the permittee must maintain a riparian buffer or structural equivalent in accordance with at least one of the following options. The selection and location must be described in the SWPPP.
- (a) Provide and maintain a 50-foot undisturbed natural buffer; or
 - (b) Provide and maintain an undisturbed natural buffer that is less than 50 feet and is supplemented by erosion and sediment controls that achieve the sediment load reduction equivalent to a 50-foot undisturbed natural buffer; or
 - (c) If infeasible to provide and maintain an undisturbed natural buffer of any size, implement erosion and sediment controls to achieve the sediment load reduction equivalent to a 50-foot undisturbed natural buffer.
 - (d) The permittee is not required to comply with (a), (b), or (c) above if one or more of the following exceptions apply and documentation is provided in the SWPPP:
 - 1) As authorized per CWA Section 404 Department of the Army permit and its associated Section 401 Water Quality Certification from the Department.
 - 2) If there is no discharge of stormwater to waters of the state through the area between the disturbed portions of the site and waters of the state located within 50 feet of the site. This includes situations where the permittee has implemented permanent control measures that will prevent such discharges, such as a berm or other barrier.
 - 3) Where no natural buffer exists due to preexisting development disturbances that occurred prior to the initiation of planning for the current development of the site.
 - a. Where some natural buffer exists but portions of the area within 50 feet of the waters of the state are occupied by preexisting development disturbances the permittee is required to comply with (a), (b), or (c) above.
 - 4) For linear projects where site constraints make it infeasible to implement a buffer or equivalent provided the permittee limit disturbances within 50 feet of any waters of the state and/or the permittee provides supplemental erosion and sediment controls to treat stormwater discharges from earth disturbances within 50 feet of the water of the state. The permittee must also document in the SWPPP the rationale for why it is infeasible for the permittee to implement (a), (b), or (c) and describe any buffer width retained and supplemental BMPs installed.
 - (e) Where the permittee is retaining a buffer of any size, the buffer should be measured perpendicularly from any of the following points, whichever is further landward from the water:
 - 1) The ordinary high water mark of the water body, defined as the line on the shore established by fluctuations of water and indicated by physical characteristics such as a clear, natural line impressed on the bank, shelving, changes in the character of soil, destruction of terrestrial vegetation, and/or the presence of litter and debris; or
 - 2) The edge of the stream or river bank, bluff, or cliff, whichever is applicable.
8. Slopes for disturbed areas must be identified in the SWPPP. A site map or maps defining the sloped areas for all phases of the project must be included in the SWPPP. The disturbance of steep slopes shall be minimized.
9. Manage stockpiles or land clearing debris piles composed, in whole or in part, of sediment and/or soil.
- (a) Locate the piles outside of any natural buffers zones, established under the condition above, and away from any stormwater conveyances, drain inlets, and areas where stormwater flow is concentrated;
 - (b) Install a sediment barrier along all downgradient perimeter areas;
 - (c) Divert surface flows around stockpiles to reduce and minimize erosion of the stockpile.

- (d) For piles that will be unused for 14 or more days, provide cover with appropriate temporary stabilization in accordance with Part V. BMP REQUIREMENTS, Condition 13.
 - (e) Rinsing, sweeping, or otherwise placing any soil, sediment, debris, or stockpiled product which has accumulated on pavement or other impervious surfaces into any stormwater conveyance, storm drain inlet, or water of the state is prohibited.
10. The site shall include BMPs for pollution prevention measures and shall be noted in the SWPPP. At minimum such measures must be designed, installed, implemented, and maintained to:
- (a) Minimize the discharge of pollutants from equipment and vehicle rinsing; no detergents, additives, or soaps of any kind shall be discharged. Rinse waters must be treated in a sediment basin or alternative control that provides equivalent or better treatment prior to discharge;
 - (b) Minimize the exposure of building materials, building products, construction wastes, trash, landscape materials, fertilizers, pesticides, herbicides, detergents, sanitary waste, and other materials present on the site to precipitation and to stormwater;
 - (c) Minimize the discharge of pollutants from spills and leaks and implement chemical spill and leak prevention and response procedures, including, but not limited to, the installation of containment berms and use of drip pans at petroleum product and liquid storage tanks and containers; and
 - (d) Prevent discharges from causing or contributing to an exceedance of water quality standards including general criteria.
11. Sedimentation Basins: The SWPPP shall include a sedimentation basin for each drainage area with ten or more acres disturbed at one time.
- (a) The sedimentation basin shall be sized, at a minimum, to treat a local 2-year, 24-hour storm.
 - (b) Sediment basins shall not be constructed in any waters of the state or natural buffer zones.
 - (c) Discharges from dewatering activities shall be managed by appropriate controls. The SWPPP shall include a description of any anticipated dewatering methods and specific BMPs designed to treat dewatering water.
 - 1) Appropriate controls include, but are not limited to, sediment socks, dewatering tanks, tube settlers, weir tanks, filtration systems (e.g. bag or sand filters), and passive treatment systems that are designed to remove or retain sediment.
 - 2) Erosion controls and velocity dissipation devices (e.g., check dams, riprap, and vegetated buffers) to minimize erosion at inlets, outlets, and discharge points from shall be utilized.
 - 3) Water with an oil sheen shall not be discharged and shall be marked in SWPPP.
 - 4) Visible floating solids and foam shall not be discharged.
 - (d) Until final stabilization has been achieved, sediment basins and impoundments shall utilize outlet structures or floating skimmers that withdraw water from the surface when discharging.
 - 1) Under frozen conditions, it may be considered infeasible to withdraw water from the surface and an exception can be made for that specific period as long as discharges that may contain sediment and other pollutants are managed by appropriate controls. If determined infeasible due to frozen conditions, documentation must be provided in the SWPPP to support the determination, including the specific conditions or time period when this exception applies.
 - (e) Accumulated sediment shall not exceed 50% of total volume or as prescribed in the design, whichever is less. Note in the SWPPP the locations for disposal of the material removed from sediment basins.
 - (f) Prevent discharges to the receiving stream causing excessive visual turbidity. For the purposes of this permit, visual turbidity refers to a sediment plume or other cloudiness in the water caused by sediment that can be identified by an observer.
 - (g) The SWPPP shall require the basin be maintained until final stabilization of the disturbed area served by the basin.

Where use of a sediment basin is infeasible, the SWPPP shall evaluate and specify other similarly effective BMPs to be employed to control erosion and sediment. These similarly effective BMPs shall be selected from appropriate BMP guidance documents authorized by this permit. The BMPs must provide equivalent water quality protection to achieve compliance with this permit. The SWPPP shall require both temporary and permanent sedimentation basins to have a stabilized spillway to minimize the potential for erosion of the spillway or basin embankment.

12. Soil disturbing activities on site that have ceased either temporarily or permanently shall initiate stabilization immediately in accordance with the options below. For soil disturbing activities that have been temporarily ceased on any portion of the site and will not resume for a period exceeding 14 calendar days:
 - (a) The permittee shall construct BMPs to establish interim stabilization; and
 - (b) Stabilization must be initiated immediately and completed within 14 calendar days.
 - (c) For soil disturbing activities that have been permanently ceased on any portion of the site, final stabilization of disturbed areas must be initiated immediately and completed within 14 calendar days.
 - 1) Allowances to the 14-day completion period for temporary and final stabilization may be made due to weather and equipment malfunctions. The use of allowances shall be documented in the SWPPP. Allowances may be determined unnecessary after review by the Department.
 - (d) Until stabilization is complete, interim sediment control shall consist of well-established and maintained BMPs that are reasonably certain to protect waters of the state from sediment pollution over an extended period of time. This may require adding more BMPs to an area than is normally used during daily operations. The types of BMPs used must be suited to the area disturbed, taking into account the number of acres exposed and the steepness of the slopes. If the slope of the area is greater than 3:1 (three feet horizontal to one foot vertical), then the permittee shall establish interim stabilization within seven days of ceasing operations on that part of the site. The following activities would constitute the immediate initiation of stabilization:
 - 1) Prepping the soil for vegetative or non-vegetative stabilization as long as seeding, planting, and/or installation of non-vegetative stabilization products takes place as soon as practicable;
 - 2) Applying mulch or other non-vegetative product to the exposed areas;
 - 3) Seeding or planting the exposed areas;
 - 4) Finalizing arrangements to have stabilization product fully installed in compliance with the deadlines for completing stabilization.
 - (e) If vegetative stabilization measures are being implemented, stabilization is considered “installed” when all activities necessary to seed or plant the area are completed. Installed does not mean established.
 - (f) If non-vegetative stabilization measures are being implemented, stabilization is considered “installed” when all such measures are implemented or applied.
 - 1) Non-vegetative stabilization shall prevent erosion and shall be chosen for site conditions, such as slope and flow of stormwater.
 - (g) Final stabilization is not considered achieved until vegetation has grown and established to meet the requirements below.
13. Prior to removal of BMPs, ceasing site inspections, and removing from the quarterly report, final stabilization must be achieved. Final stabilization shall be achieved as soon as possible once land disturbance activities have ceased. Document in the SWPPP the type of stabilization and the date final stabilization is achieved.
 - (a) The project is considered to have achieved final stabilization when perennial vegetation (excluding volunteer vegetation), pavement, buildings, or structures using permanent materials (e.g., riprap, gravel, etc.) cover all areas that have been disturbed. With respect to areas that have been vegetated, vegetation must be at least 70% coverage of 100% of the vegetated areas on site. Vegetation must be evenly distributed.
 - (b) Disturbed areas on agricultural land are considered to have achieved final stabilization when they are restored to their preconstruction agricultural use. If former agricultural land is changing to non-agricultural use, this is no longer considered agricultural land and shall follow condition (a).
 - (c) If the intended function of a specific area of the site necessitates that it remain disturbed, final stabilization is considered achieved if all of the following are met:
 - 1) Only the minimum area needed remains disturbed (i.e., dirt access roads, motocross tracks, utility pole pads, areas being used for storage of vehicles, equipment, materials). Other areas must meet the criteria above.

- 2) Permanent structural BMPs (e.g., rock checks, berms, grading, etc.) or non-vegetative stabilization measures are implemented and designed to prevent sediment and other pollutants from entering waters of the state.
- 3) Inspection requirements in Part IV. SWPPP MANAGEMENT REQUIREMENT, Condition 11 are met and documented in the SWPPP.
- (d) Winter weather and frozen conditions do not excuse any of the above final stabilization requirements. If vegetation is required for stabilization the permittee must maintain BMPs throughout winter weather and frozen conditions until thawing and vegetation meets final stabilization criteria above. Document stabilization attempts during frozen conditions in the SWPPP. Consider future freezing when removing vegetation and plan with temporary stabilization techniques before the ground becomes frozen.

VI. SITE FINALIZATION & PERMIT TERMINATION

1. Until a site is finalized, the permittee must comply with all conditions in the permit, including continuation of site inspections and reporting quarterly to the Department. To finalize the site and remove from this permit coverage, the site shall meet the following requirements:
 - (a) For any areas that (1) were disturbed during construction, (2) are not covered over by permanent structures, and (3) over which the permittee had control during the construction activities, the requirements for final vegetative or non-vegetative stabilization in Part V. BMP REQUIREMENTS, Condition 13;
 - (b) The permittee has removed and properly disposed of all construction materials, waste, and waste handling devices and has removed all equipment and vehicles that were used during construction, unless intended for long-term beyond construction phase;
 - (c) The permittee has removed all temporary BMPs that were installed and maintained during construction, except those that are intended for long-term use or those that are biodegradable; and
 - (d) The permittee has removed all potential pollutants and pollutant-generating activities associated with construction, unless needed for long-term use following the construction activities.
2. The permit may be terminated if;
 - (a) There has been a transfer of control of all areas of the site for which the current permittee is responsible under this permit to another operator, and that operator has obtained coverage under this permit;
 - (b) Active sites obtain coverage under an individual or alternative general NPDES permit, with land disturbance conditions; or
 - (c) This permit may be terminated when all projects covered under this permit are finalized. In order to terminate the permit, the permittee shall notify the Department by submitting a Request for Termination along with the final quarterly report for the current calendar quarter.

VII. REPORTING AND SAMPLING REQUIREMENTS

1. The permittee is not required to sample stormwater under this permit. The Department may require sampling and reporting as a result of illegal discharges, compliance issues related to water quality concerns, or evidence of off-site impacts from activities at a site. If such an action is needed, the Department will specify in writing the sampling requirements, including such information as location and extent. If the permittee refuses to perform sampling when required, the Department may terminate the general permit and require the facility to obtain a site-specific permit with sampling requirements.
2. Electronic Discharge Monitoring Report (eDMR) Submission System. The NPDES Electronic Reporting Rule, 40 CFR Part 127, reporting of any report required by the permit shall be submitted via an electronic system to ensure timely, complete, accurate, and nationally consistent set of data for the NPDES program. The eDMR system is currently the only Department-approved reporting method for this permit unless specified elsewhere in this permit, or a waiver is granted by the Department. The facility must register in the Department's eDMR system through the Missouri Gateway for Environmental Management (MoGEM) before the first report is due.
3. Permittees shall prepare a quarterly report with a list of active land disturbance sites including any off-site borrow or depositional areas associated with the construction project and submit the following information electronically as an

attachment to the eDMR system until such a time when the current or a new system is available to allow direct input of the data:

- (a) The name of the project;
- (b) The location of the project (including the county);
- (c) The name of the primary receiving water(s) for each project;
- (d) A description of the project;
- (e) The number of acres disturbed;
- (f) The percent of completion of the project; and
- (g) The projected date of completion.

The quarterly report(s) shall be maintained by the permittee and readily available for review by the Department at the address provided on the application as well as submitted quarterly via the Department’s eDMR system. The permittee shall submit quarterly reports according to Table A.

| Table A | Schedule for Quarterly Reporting |
|---|---|
| Activity for the months of: | Report is due: |
| January, February, March (1st Quarter) | April 28 |
| April, May, June (2nd Quarter) | July 28 |
| July, August, September (3rd Quarter) | October 28 |
| October, November, December (4th Quarter) | January 28 |

VIII. STANDARD PERMIT CONDITIONS

1. Records: The permittee shall retain copies of this general permit, the SWPPP and all amendments for the site named in the State Operating Permit, results of any monitoring and analysis, and all site inspection records required by this general permit.
 - (a) The records shall be accessible during normal business hours and retained for a period of at least three (3) years from the date of termination.
 - (b) The permittee shall provide a copy (electronic or otherwise) of the SWPPP to the Department, USEPA, or any local agency or government representative if they request a copy in the performance of their official duties within 24 hours of the request (or next working day), unless given more time by the representative.
 - (c) The permittee shall provide a copy of the SWPPP to those who are responsible for installation, operation, or maintenance of any BMP. The permittee, their representative, and/or the contractor(s) responsible for installation, operation and maintenance of the BMPs shall have a current copy of the SWPPP with them when on the project site.

2. Land Ownership and Change of Ownership: Federal and Missouri stormwater regulations [10 CSR 20-6.200(1) (B)] require a stormwater permit and erosion control measures for all land disturbances of one or more acres. These regulations also require a permit for less than one acre lots if the lot is part of a larger common plan of development or sale where that plan is at least one acre in size.
 - (a) If the permittee sells any portion of a permitted site to a developer for commercial, industrial, or residential use, this land remains a part of the common sale and the new owner must obtain a permit prior to conducting any land disturbance activity. Therefore, the original permittee must amend the SWPPP to show that the property has been sold and, therefore, no longer under the original permit coverage.
 - (b) Property of any size which is part of a larger common plan of development where the property has achieved final stabilization and the original permit terminated will require application of a new land disturbance permit for any future land disturbance activity unless the activity is by an individual residential building lot owner on a site less than one acre.
 - (c) If a portion of a larger common plan of development is sold to an individual for the purpose of building his or her own private residence, a permit is required if the portion of land sold is equal to or greater than one acre. No permit is required, however, for less than one acre of land sold.

3. Permit Transfer: This permit may not be transferred to a new owner.

4. Termination: This permit may be terminated when the project has achieved final stabilization, defined in Part VI. **SITE FINALIZATION & PERMIT TERMINATION.**
 - (a) In order to terminate the permit, the permittee shall notify the Department by submitting the form Request for Termination of Operating Permit Form MO 780-2814. The form should be submitted to the appropriate regional office or through an approved electronic system if it should become available.
 - (b) The Cover Page (Certificate Page) of the Master General Permit for Land Disturbance specifies the “effective date” and the “expiration date” of the Master General Permit. The “issued date” along with the “expiration date” will appear on the State Operating Permit issued to the applicant. **This permit does not continue administratively beyond the expiration date.**
5. Duty to Reapply: If the project or development completion date will be after the expiration date of this general permit, then the permittee must reapply to the Department for a new permit. This permit may be applied for and issued electronically in accordance with Section 644.051.10, RSMo.
 - (a) Due to the nature of the electronic permitting system, a period of time may be granted at the discretion of the Department in order to apply for a new permit after the new version is effective. Applicants must maintain appropriate best management practices and inspections during the discretionary period.
6. Duty to Comply: The permittee must comply with all conditions of this permit. Any permit noncompliance constitutes a violation of the Missouri Clean Water Law and Federal Clean Water Act and is grounds for enforcement action; for permit termination, revocation and reissuance, or modification; or denial of a permit renewal application.
7. Modification, Revocation, and Reopening:
 - (a) If at any time the Department determines that the quality of waters of the state may be better protected by reopening this permit, or revoking this permit and requiring the owner/operator of the permitted site to apply for a site-specific permit, the Department may revoke a general permit and require any person to obtain such an operating permit as authorized by 10 CSR20-6.010(13) and 10 CSR 20-6.200(1)(B).
 - (b) If this permit is reopened, modified, or revoked pursuant to this Section, the permittee retains all rights under Chapter 536 and 644 Revised Statutes of Missouri upon the Department’s reissuance of the permit as well as all other forms of administrative, judicial, and equitable relief available under law.
8. Other Information: Where the permittee becomes aware that it failed to submit any relevant facts in a permit application or submitted incorrect information in a permit application or in any report to the Department, it shall promptly submit such facts or information.
9. Duty to Provide Information: The permittee shall furnish to the Department, within 24 hours unless explicitly granted more time in writing, any information which the Department may request to determine whether cause exists for modifying, revoking and reissuing, or terminating this permit or to determine compliance with this permit. The permittee shall also furnish to the Department upon request, copies of records required to be kept by this permit.
10. Inspection and Entry: The permittee shall allow the Department, or an authorized representative (including an authorized contractor acting as a representative of the Department), upon presentation of credentials and other documents as may be required by law, to:
 - (a) Enter upon the permittee's premises where a regulated facility or activity is located or conducted or where records must be kept under the conditions of the permit;
 - (b) Have access to and copy, at reasonable times, any records that must be kept under the conditions of this permit;
 - (c) Inspect at reasonable times any facilities, equipment (including monitoring and control equipment), practices, or operations regulated or required under this permit; and
 - (d) Sample or monitor at reasonable times, for the purposes of assuring permit compliance or as otherwise authorized by the Federal Clean Water Act or Missouri Clean Water Law, any substances or parameters at any location.

11. Signatory Requirement:

- (a) All permit applications, reports required by the permit, or information requested by the Department shall be signed and certified. (See 40 CFR 122.22 and 10 CSR 20-6.010)
- (b) The Federal Clean Water Act provides that any person who knowingly makes any false statement, representation, or certification in any record or other document submitted or required to be maintained under this permit (including monitoring reports or reports of compliance or non-compliance) shall, upon conviction, be punished by a fine of not more than \$10,000 per violation, or by imprisonment for not more than six (6) months per violation, or by both.
- (c) The Missouri Clean Water Law provides that any person who knowingly makes any false statement, representation or certification in any application, record, report, plan, or other document filed or required to be maintained pursuant to sections 644.006 to 644.141 shall, upon conviction, be punished by a fine of not more than ten thousand dollars, or by imprisonment for not more than six months, or by both.

12. Property Rights: This permit does not convey any property rights of any sort or any exclusive privilege.

13. Notice of Right to Appeal: If you were adversely affected by this decision, you may be entitled to pursue an appeal before the administrative hearing commission (AHC) pursuant to Sections 621.250 and 644.051.6 RSMo. To appeal, you must file a petition with the AHC within thirty days after the date this decision was mailed or the date it was delivered, whichever date was earlier. If any such petition is sent by registered mail or certified mail, it will be deemed filed on the date it is mailed; if it is sent by any method other than registered mail or certified mail, it will be deemed filed on the date it is received by the AHC. Any appeal should be directed to:

Administrative Hearing Commission
U.S. Post Office Building, Third Floor
131 West High Street, P.O. Box 1557
Jefferson City, MO 65102-1557
Phone: 573-751-2422
Fax: 573-751-5018
Website: <https://ahc.mo.gov>



MISSOURI
DEPARTMENT OF
NATURAL RESOURCES

STORMWATER DISCHARGES FROM
THIS LAND DISTURBANCE SITE ARE
AUTHORIZED BY THE MISSOURI
STATE OPERATING PERMIT NUMBER:

ANYONE WITH QUESTIONS OR
CONCERNS ABOUT STORMWATER
DISCHARGES FROM THIS SITE,
PLEASE CONTACT THE MISSOURI
DEPARTMENT OF NATURAL
RESOURCES AT

1-800-361-4827

MISSOURI DEPARTMENT OF NATURAL RESOURCES
FACT SHEET FOR MASTER GENERAL PERMIT
MO-R100xxx

The Federal Water Pollution Control Act [Clean Water Act (CWA)] Section 402 of Public Law 92-500 (as amended) established the National Pollution Discharge Elimination System (NPDES) permit program. This program regulates the discharge of pollutants from point sources into the waters of the United States and the release of stormwater from certain point sources. All such discharges are unlawful without a permit (Section 301 of the CWA). After a permit is obtained, a discharge not in compliance with all permit terms and conditions is unlawful. Missouri State Operating Permits (MSOPs) are issued by the Missouri Department of Natural Resources (Department) under an approved program operated in accordance with federal and state laws (Federal CWA and Missouri Clean Water Law Section 644 as amended). Permits are issued for a period of five (5) years unless otherwise specified.

Per 40 CFR 124.56, 40 CFR 124.8, and 10 CSR 20-6.020(1)(A)2, a Fact Sheet shall be prepared to give pertinent information regarding the applicable regulations, rationale for the development of effluent limitations and conditions, and the public participation process for the permit. A Fact Sheet is not an enforceable part of an MSOP.

DEFINITIONS FOR THE PURPOSES OF THIS PERMIT:

Common Promotional Plan: A plan undertaken by one (1) or more persons to offer lots for sale or lease; where land is offered for sale by a person or group of persons acting in concert, and the land is contiguous or is known, designated, or advertised as a common unit or by a common name or similar names, the land is presumed, without regard to the number of lots covered by each individual offering, as being offered for sale or lease as part of a common promotional plan.

Dewatering: The act of draining rainwater and/or groundwater from basins, building foundations, vaults, and trenches.

Effective Operating Condition: For the purposes of this permit, a stormwater control is kept in effective operating condition if it has been implemented and maintained in such a manner that it is working as designed to minimize pollutant discharges.

Emergency-Related Project: A project initiated in response to a public emergency (e.g. earthquakes, extreme flooding conditions, tornado, disruptions in essential public services, pandemic) for which the related work requires immediate authorization to avoid imminent endangerment to human health/safety or the environment or to reestablish essential public services.

Exposed Soils: For the purposes of this permit, soils that as a result of earth-disturbing activities are left open to the elements.

Immediately: For the purposes of this permit, immediately should be defined as within 24 hours.

Impervious Surface: For the purpose of this permit, any land surface with a low or no capacity for soil infiltration including, but not limited to, pavement, sidewalks, parking areas and driveways, packed gravel or soil, or rooftops.

Infeasible: Infeasible means not technologically possible or not economically practicable and achievable in light of best industry practices.

Install or Installation: When used in connection with stormwater controls, to connect or set in position stormwater controls to make them operational.

Land Disturbance Site or Site: The land or water area where land disturbance activities will occur and where stormwater controls will be installed and maintained. The land disturbance site includes construction support activities, which may be located at a different part of the property from where the primary land disturbance activity will take place or on a different piece of property altogether. Off-site borrow areas directly and exclusively related to the land disturbance activity are part of the site and must be permitted.

Larger Common Plan of Development or Sale: A continuous area where multiple separate and distinct construction activities are occurring under one plan, including any off-site borrow areas that are directly and exclusively related to the land disturbance activity. Off-site borrow areas utilized for multiple different land disturbance projects are considered their own entity and are not part of the larger common plan of development or sale. See definition of Common Promotional Plan to understand what a ‘common plan’ is.

Minimize: To reduce and/or eliminate to the extent achievable using stormwater controls that are technologically available and economically practicable and achievable in light of best industry practices.

Non-structural Best Management Practices (BMPs): Institutional, educational, or pollution prevention practices designed to limit the amount of stormwater runoff or pollutants that are generated in the landscape. Examples of non-structural BMPs include picking up trash and debris, sweeping up nearby sidewalks and streets, maintaining equipment, and training site staff on stormwater control practices.

Operational: for the purposes of this permit, stormwater controls are made “operational” when they have been installed and implemented, are functioning as designed, and are properly maintained.

Ordinary High Water Mark: The line on the shore established by fluctuations of water and indicated by physical characteristics such as a clear, natural line impressed on the bank, shelving, changes in the character of soil, destruction of terrestrial vegetation, and/or the presence of litter and debris.

Peripheral: For the purposes of this permit, peripheral should be defined as the outermost boundary of the area that will be disturbed.

Permanently: For the purposes of this permit, permanently is defined as any activity that has been ceased without any intentions of future disturbance.

Pollution Prevention Controls (or Measures): Stormwater controls designed to reduce or eliminate the addition of pollutants to construction site discharges through analysis of pollutant sources, implementation of proper handling/disposal practices, employee education, and other actions.

Qualified Person (inspections): A person knowledgeable in the principles and practice of erosion and sediment controls and pollution prevention who possesses the appropriate skills and training to assess conditions at the construction site that could impact stormwater quality and the appropriate skills and training to assess the effectiveness of any stormwater controls selected and installed to meet the requirements of this permit.

Stormwater Control (also referred to as sediment/erosion controls): refers to any temporary or permanent BMP or other method used to prevent or reduce the discharge of pollutants to waters of the state.

Structural BMP: Physical sediment/erosion controls working individually or as a group (treatment train) appropriate to the source, location, and area climate for the pollutant to be controlled. Examples of structural BMPs include silt fences, sedimentation ponds, erosion control blankets, and seeding.

Temporary Stabilization: A condition where exposed soils or disturbed areas are provided temporary vegetation and/or non-vegetative protective cover to prevent erosion and sediment loss. Temporary stabilization may include temporary seeding, geotextiles, mulches, and other techniques to reduce or eliminate erosion until either final stabilization can be achieved or until further construction activities take place to re-disturb this area.

Treatment Train: A multi-BMP approach to managing the stormwater volume and velocity and often includes erosion prevention and sediment control practices often applied when the use of a single BMP is inadequate in preventing the erosion and transport of sediment. A good option to utilize as a corrective action.

Volunteer Vegetation: A volunteer plant is a plant that grows on its own, rather than being deliberately planted for stabilization purposes. Volunteers often grow from seeds that float in on the wind, are dropped by birds, or are inadvertently mixed into soils. Commonly, volunteer vegetation is referred to as 'weeds'. This does not meet the requirements for final stabilization.

Waters of the State: Section 644.016.1(27) RSMo. defines waters of the state as, "All waters within the jurisdiction of this state, including all rivers, streams, lakes and other bodies of surface and subsurface water lying within or forming a part of the boundaries of the state which are not entirely confined and located completely upon lands owned, leased or otherwise controlled by a single person or by two or more persons jointly or as tenants in common."

PART I – BASIC PERMIT INFORMATION

Facility Type: Industrial Stormwater; Land Disturbance
Facility SIC Code(s): 1629
Facility Description: Construction or land disturbance activity (e.g., clearing, grubbing, excavating, grading, filling, and other activities that result in the destruction of the root zone and/or land disturbance activity that is reasonably certain to cause pollution to waters of the state).

This permit establishes a Stormwater Pollution Prevention Plan (SWPPP) requirement for pollutants of concern from this type of facility or for all facilities and sites covered under this permit. 10 CSR 20-6.200(7) specifies "general permits shall contain BMP requirements and/or monitoring and reporting requirements to keep the stormwater from becoming contaminated".

Land disturbance activities include clearing, grubbing, excavating, grading, filling and other activities that result in the destruction of the root zone and/or other activities that are reasonably certain to cause pollution to waters of the state. A Missouri State Operating Permit for land disturbance permit is required for construction disturbance activities of one or more acres or for construction activities that disturb less than one acre when they are part of a larger common plan of development or sale that will disturb a cumulative total of one or more acres over the life of the project.

The primary requirement of a land disturbance permit is the development of a SWPPP which incorporates site-specific BMPs to minimize soil exposure, soil erosion, and the discharge of pollutants. The SWPPP ensures the design, implementation, management, and maintenance of BMPs in order to prevent sediment and other pollutants from leaving the site.

When it precipitates, stormwater washes over the loose soil on a construction site and various other materials and products being stored outside. As stormwater flows over the site, it can pick up pollutants like sediment, debris, and chemicals from the loose soil and transport them to nearby storm sewer systems or directly into rivers, lakes, or coastal waters.

The Missouri Department of Natural Resources is responsible for ensuring that construction site operators have the proper stormwater controls in place so that construction can proceed in a way that protects your community's clean water and the surrounding environment. One way the department helps protect water quality is by issuing land disturbance permits.

Local conditions are not considered when developing conditions for a general permit. A facility may apply for a site-specific permit if they desire a review of site-specific conditions.

PART II – RECEIVING STREAM INFORMATION

APPLICABLE DESIGNATIONS OF WATERS OF THE STATE:

Per Missouri Effluent Regulations (10 CSR 20-7.015), the waters of the state are divided into seven (7) categories. This permit applies to facilities discharging to the following water body categories:

- ✓ Missouri or Mississippi River [10 CSR 20-7.015(2)]
- ✓ Lakes or Reservoirs [10 CSR 20-7.015(3)]
- ✓ Losing Streams [10 CSR 20-7.015(4)]
- ✓ Metropolitan No-Discharge Streams [10 CSR 20-7.015(5)]
- ✓ Special Streams [10 CSR 20-7.015(6)]
- ✓ Subsurface Waters [10 CSR 20-7.015(7)]
- ✓ All Other Waters [10 CSR 20-7.015(8)]

Missouri Water Quality Standards (10 CSR 20-7.031) defines the Clean Water Commission water quality objectives in terms of "water uses to be maintained and the criteria to protect those uses." The receiving stream and/or 1st classified receiving stream's designated water uses shall be maintained in accordance with 10 CSR 20-7.031(24). A general permit does not take into consideration site-specific conditions.

MIXING CONSIDERATIONS:

This permit applies to receiving streams of varying low flow conditions. Therefore, the effluent limitations must be based on the smallest low flow streams considered, which includes waters without designated uses. As such, no mixing is allowed [10 CSR 20-7.031(5)(A)4.B.(I)(a)]. No Zone of Initial Dilution is allowed. [10 CSR 20-7.031(5)(A)4.B.(I)(b)].

RECEIVING STREAM MONITORING REQUIREMENTS:

There are no receiving water monitoring requirements recommended at this time.

PART III – RATIONALE AND DERIVATION OF EFFLUENT LIMITATIONS & PERMIT CONDITIONS

305(B) REPORT, 303(d) LIST, & TOTAL MAXIMUM DAILY LOAD (TMDL):

Section 305(b) of the Federal CWA requires each state identify waters not meeting Water Quality Standards and for which adequate water pollution controls have not been required. Water Quality Standards protect such beneficial uses of water as whole body contact, maintaining fish and other aquatic life, and providing drinking water for people, livestock, and wildlife. The 303(d) list helps state and federal agencies keep track of waters which are impaired but not addressed by normal water pollution control programs.

A TMDL is a calculation of the maximum amount of a given pollutant a body of water can absorb before its water quality is affected. If a water body is determined to be impaired as listed on the 303(d) list, then a watershed management plan will be developed which shall include the TMDL calculation. For facilities with an existing general permit before a TMDL is written on their receiving stream, the Department will evaluate the permit and may require any facility authorized by this general permit to apply for and obtain a site-specific operating permit.

ANTI-BACKSLIDING:

A provision in the Federal Regulations [CWA Section 303(d)(4); CWA Section 402(c); 40 CFR Part 122.44(I)] requires a reissued permit to be as stringent as the previous permit with some exceptions.

- ✓ Not Applicable: All effluent limitations in this permit are at least as protective as those previously established.

ANTIDEGRADATION:

Antidegradation policies ensure protection of water quality for a particular water body on a pollutant by pollutant basis to ensure Water Quality Standards are maintained to support beneficial uses such as fish and wildlife propagation and recreation on and in the water. This also includes special protection of waters designated as an Outstanding National Resource Water or Outstanding State Resource Water [10 CSR 20-7.031(3)(C)]. Antidegradation policies are adopted to minimize adverse effects on water.

The Department has determined the best avenue forward for implementing the Antidegradation requirements into general stormwater permits is by requiring the appropriate development and maintenance of a SWPPP. The SWPPP must identify all reasonable and effective BMPs, taking into account environmental impacts and costs. This analysis must document why no discharge or no exposure options are not feasible at the facility. This selection and documentation of appropriate control measures will then serve as the analysis of alternatives and fulfill the requirements of the Antidegradation Rule and Implementation Procedure 10 CSR 20-7.031(3) and 10 CSR 20-7.015(9)(A)5.

Any facility seeking coverage under this permit which undergoes expansion or discharges a new pollutant of concern must update their SWPPP and select reasonable and cost effective new BMPs. New facilities seeking coverage under this permit are required to develop a SWPPP including this analysis and documentation of appropriate BMPs. Renewal of coverage for a facility requires a review of the SWPPP to ensure the selected BMPs continue to be appropriate.

- ✓ Applicable; the facility must review and maintain stormwater BMPs as appropriate.

BENCHMARKS:

When a permitted feature or outfall consists of only stormwater, a benchmark may be implemented at the discretion of the permit writer. Benchmarks require the facility to monitor and, if necessary, replace and update stormwater control measures. Benchmark concentrations are not effluent limitations. A benchmark exceedance, therefore, is not a permit violation; however, failure to take corrective action is a violation of the permit. Benchmark monitoring data is used to determine the overall effectiveness of control measures and to assist the permittee in knowing when additional corrective actions may be necessary to comply with the limitations of the permit.

- ✓ Not applicable; this permit does not contain numeric benchmarks.

BEST MANAGEMENT PRACTICES (BMPs):

Minimum site-wide BMPs are established in this permit to ensure all permittees are managing their sites equally to protect waters of the state from certain activities which could cause negative effects in receiving water bodies. While not all sites require a SWPPP because the SIC codes are specifically exempted in 40 CFR 122.26(b)(14), these BMPs are not specifically included for stormwater purposes. These practices are minimum requirements for all industrial sites to protect waters of the state. If the minimum BMPs are not followed, the facility may violate general criteria [10 CSR 20-7.031(4)]. Statutes are applicable to all permitted facilities in the state; therefore, pollutants cannot be released unless in accordance with RSMo 644.011 and 644.016 (17).

CHANGES IN DISCHARGES OF TOXIC POLLUTANT:

This special condition reiterates the federal rules found in 40 CFR 122.44(f) and 122.42(a)(1). In these rules, the facility is required to report changes in amounts of toxic substances discharged. Toxic substances are defined in 40 CFR 122.2 as "...any pollutant listed as toxic under section 307(a)(1) or, in the case of "sludge use or disposal practices," any pollutant identified in regulations implementing section 405(d) of the CWA." Section 307 of the CWA then refers to those parameters found in 40 CFR 401.15.

The permittee should also consider any other toxic pollutant in the discharge as reportable under this condition.

EFFLUENT LIMITATION GUIDELINE:

Effluent Limitation Guidelines, or ELGs, are found at 40 CFR 400-499. These are limitations established by the EPA based on the SIC code and the type of work a facility is conducting. Most ELGs are for process wastewater and some address stormwater. All are technology based limitations which must be met by the applicable facility at all times.

- ✓ The industries covered under this permit have an associated Effluent Limit Guideline (ELG) which is applicable to the stormwater discharges in this permit and is applied under 40 CFR 125.3(a).

ELECTRONIC DISCHARGE MONITORING REPORT (EDMR) SUBMISSION SYSTEM:

The U.S. Environmental Protection Agency (EPA) promulgated a final rule on October 22, 2015, to modernize CWA reporting for municipalities, industries, and other facilities by converting to an electronic data reporting system. The final rule requires regulated entities and state and federal regulators to use information technology to electronically report data required by the National Pollutant Discharge Elimination System (NPDES) permit program instead of filing paper reports. To comply with the federal rule, the Department is requiring all permittees to begin submitting discharge monitoring data and reports online.

- ✓ Applicable; this permit requires quarterly reports.

GENERAL CRITERIA CONSIDERATIONS:

In accordance with 40 CFR 122.44(d)(1), effluent limitations shall be placed into permits for pollutants determined to cause, have reasonable potential to cause, or to contribute to, an excursion above any water quality standard, including narrative water quality criteria. In order to comply with this regulation, the permit writer has completed a reasonable potential determination on whether discharges have reasonable potential to cause or contribute to an excursion of the general criteria listed in 10 CSR 20-7.031(4). In instances where reasonable potential exists, the permit includes limitations within the permit to address the reasonable potential. In discharges where reasonable potential does not exist, the permit may include monitoring to later determine the discharge's potential to impact the narrative criteria. Additionally, RSMo 644.076.1, as well as Standard Permit Conditions Part VIII of this permit state it shall be unlawful for any person to cause or allow any discharge of water contaminants from any water contaminant or point source located in Missouri in violation of sections 644.006 to 644.141 of the Missouri Clean Water Law or any standard, rule, or regulation promulgated by the commission.

LAND APPLICATION:

Land application, or surficial dispersion of wastewater and/or sludge, is performed by facilities to maintain a basin as no-discharge. Requirements for these types of operations are found in 10 CSR 20-6.015; authority to regulate these activities is from RSMo 644.026.

- ✓ Not applicable; this permit does not authorize operation of a surficial land application system to disperse wastewater or sludge.

LAND DISTURBANCE:

Land disturbance, sometimes called construction activities, are actions which cause disturbance of the root layer or soil; these include clearing, grading, and excavating of the land. 40 CFR 122.26(b)(14) and 10 CSR 20-6.200(3) requires permit coverage for these activities. Coverage is not required for facilities when only providing maintenance of original line and grade, hydraulic capacity, or to continue the original purpose of the facility.

- ✓ Applicable; this permit provides coverage for land disturbance activities. These activities have SWPPP requirements and may be combined with the standard site SWPPP. Land disturbance BMPs should be designed to control the expected peak discharges. The University of Missouri has design storm events for the 25 year 24 hour storm; these can be found at: http://ag3.agebb.missouri.edu/design_storm/comparison_reports/20191117_25yr_24hr_comparison_able.htm; to calculate peak discharges, the website <https://www.lmnoeng.com/Hydrology/rational.php> has the rational equation to calculate expected discharge volume from the peak storm events.

NUTRIENT MONITORING:

Nutrient monitoring is required for facilities characteristically or expected to discharge nutrients (nitrogenous compounds and/or phosphorus) when the design flow is equal to or greater than 0.1 MGD per 10 CSR 20-7.015(9)(D)8.

- ✓ This is a stormwater only permit; therefore, it is not subject to provisions found in 10 CSR 20-7.015 per 10 CSR 20-7.015(1)(C).

OIL/WATER SEPARATORS:

Oil water separator (OWS) tank systems are frequently found at industrial sites where process water and stormwater may contain oils and greases, oily wastewaters, or other immiscible liquids requiring separation. Food industry discharges typically require pretreatment prior to discharge to municipally owned treatment works. Per 10 CSR 26-2.010(2)(B), all oil water separator tanks must be operated according to manufacturer's specifications and authorized in NPDES permits per 10 CSR 26-2.010(2) or may be regulated as a petroleum tank.

- ✓ Not applicable; this permit does not authorize the operation of OWS. The facility must obtain a separate permit to cover operation of and discharge from these devices.

PERMIT SHIELD:

The permit shield provision of the CWA (Section 402(k)) and Missouri Clean Water Law (644.051.16 RSMo) provides that when a permit holder is in compliance with its NPDES permit or MSOP, they are effectively in compliance with certain sections of the CWA and equivalent sections of the Missouri Clean Water Law. In general, the permit shield is a legal defense against certain enforcement actions but is only available when the facility is in compliance with its permit and satisfies other specific conditions, including having completely disclosed all discharges and all facility processes and activities to the Department at time of application. It is the facility's responsibility to ensure that all potential pollutants, waste streams, discharges, and activities, as well as wastewater land application, storage, and treatment areas, are all fully disclosed to the Department at the time of application or during the draft permit review process. Subsequent requests for authorization to discharge additional pollutants or expanded or newly disclosed flows, or for authorization for previously unpermitted and undisclosed activities or discharges, will likely require permit modification or may require the facility be covered under a site specific permit.

PRETREATMENT PROGRAM:

This permit does not regulate pretreatment requirements for facilities discharging to an accepting permitted wastewater treatment facility. If applicable, the receiving entity (the publicly owned treatment works - POTW) must ensure compliance with any effluent limitation guidelines for pretreatment listed in 40 CFR Subchapter N per 10 CSR 20-6.100. Pretreatment regulations per RSMo 644.016 are limitations on the introduction of pollutants or water contaminants into publicly owned treatment works or facilities.

- ✓ Not Applicable; the facilities covered under this permit are not required to meet pretreatment requirements under an ELG.

PUBLIC NOTICE OF COVERAGE FOR AN INDIVIDUAL FACILITY:

Public Notice of reissuance of coverage is not required unless the facility is a specific type of facility as defined in 10 CSR 20-6.200(1). The need for an individual public notification process shall be determined and identified in the permit [10 CSR 20-6.020(1)(C)5.].

- ✓ Not applicable; public notice is not required for coverage under this permit to individual facilities. The MGP is public noticed in lieu of individual permit PN requirements.

REASONABLE POTENTIAL ANALYSIS (RPA):

Federal regulation 40 CFR Part 122.44(d)(1)(i) requires effluent limitations for all pollutants which are or may be discharged at a level which will cause or have the reasonable potential to cause or contribute to an in-stream excursion above narrative or numeric water quality standard. In accordance with 40 CFR Part 122.44(d)(iii) if the permit writer determines any given pollutant has the reasonable potential to cause or contribute to an in-stream excursion above the water quality standard, the permit must contain effluent limits for the pollutant.

- ✓ The permit writer reviewed industry materials, available past inspections, and other documents and research to evaluate general and narrative water quality reasonable potential for this permit. Permit writers also use the Department's permit writer's manual, the EPA's permit writer's manual (<https://www.epa.gov/npdes/npdes-permit-writers-manual>), program policies, and best professional judgment. For each parameter in each permit, the permit writer carefully considers all applicable information regarding technology based effluent limitations, effluent limitation guidelines, and water quality standards. Best professional judgment is based on the experience of the permit writer, cohorts in the Department and resources at the EPA, research, and maintaining continuity of permits if necessary. For stormwater permits, the permit writer is required per 10 CSR 6.200(6)(B)2 to consider: A. application and other information supplied by the permittee; B. effluent guidelines; C. best professional judgment of the permit writer; D. water quality; and E. BMPs.

SCHEDULE OF COMPLIANCE (SOC):

Per § 644.051, RSMo, a permit may be issued with a Schedule of Compliance (SOC) to provide time for a facility to come into compliance with new state or federal effluent regulations, water quality standards, or other requirements. Such a schedule is not allowed if the facility is already in compliance with the new requirement or if prohibited by other statute or regulation. An SOC includes an enforceable sequence of interim requirements (e.g. actions, operations, or milestone events) leading to compliance with the Missouri Clean Water Law, its implementing regulations, and/or the terms and conditions of an operating permit. *See also* Section 502(17) of the CWA, and 40 CFR 122.2. For new effluent limitations, the permit may include interim monitoring for the specific parameter to demonstrate the facility is not already in compliance with the new requirement. Per 40 CFR 122.47(a)(1) and 10 CSR 20-7.031(11), compliance must occur as soon as possible. If the permit provides a schedule for meeting new water quality based effluent limits, an SOC must include an enforceable, final effluent limitation in the permit even if the SOC extends beyond the life of the permit.

- ✓ Not Applicable: This permit does not contain a SOC.

SETBACKS:

Setbacks, sometimes called separation distances, are common elements of permits and are established to provide a margin of safety in order to protect the receiving water and other features from accidents, spills, unusual events, etc. Specific separation distances are included in 10 CSR 20-8 for minimum design standards of wastewater structures. While wastewater is considered separately from stormwater under this permit, the guides and Chapter 8 distances may remain relevant to requirements under this permit if deemed appropriate by the permittee.

- ✓ Discharge to the watersheds of a Metropolitan No-Discharge Stream (10 CSR 20-7.031 Table F) is authorized by this permit if the discharges are in compliance with 10 CSR 20-7.015(5) and 10 CSR 20-7.031(7). Discharges to these watersheds are authorized for uncontaminated stormwater discharges only.
- ✓ This permit authorizes stormwater discharges which are located in a way to allow water to be released into sinkholes, caves, fissures, or other openings in the ground which could drain into aquifers (except losing streams) per 10 CSR 20-7.015(7). It is the best professional judgment of the permit writer to allow discharges to losing streams as the effluent is stormwater only.
- ✓ This permit authorizes stormwater discharge in the watersheds of Outstanding state Resource Waters (OSRW); Outstanding National Resources Waters (ONRW), which includes the Ozark National Riverways and the National Wild and Scenic Rivers System; and impaired waters as designated in the 305(b) Report provided no degradation of water quality occurs in the OSRW and ONRW due to discharges from the permitted facility per 10 CSR 20-7.015(6)(B) and 10 CSR 20-7.031(3)(C). Additionally, if the facility is found to be causing degradation or contributing to an impairment by discharging a pollutant of concern during an inspection or through complaint investigations, they will be required to become a no discharge facility or obtain a site specific permit with more stringent monitoring and SWPPP requirements. Missouri's impaired waters can be found at <https://dnr.mo.gov/water/what-were-doing/water-planning/quality-standards-impaired-waters-total-maximum-daily-loads/impaired-waters>. Sites within 1000 feet of a OSRW, ONRW, or water impaired for sediment must operate as a no-discharge facility. These additional protections are borrowed from the USEPA 2021 draft Construction General Permit.

SLUDGE – DOMESTIC BIOSOLIDS:

Biosolids are solid materials resulting from domestic wastewater treatment meeting federal and state criteria for beneficial use (i.e. fertilizer). Sewage sludge is solid, semi-solid, or liquid residue generated during the treatment of domestic sewage in a treatment works; including, but not limited to, domestic septage; scum or solids removed in primary, secondary, or advanced wastewater treatment process; and material derived from sewage sludge. Sewage sludge does not include ash generated during the firing of sewage sludge in a sewage sludge incinerator or grit and screening generated during preliminary treatment of domestic sewage in a treatment works.

- ✓ This permit does not authorize discharge or land application of biosolids. Sludge/biosolids is not generated by this industry.

SLUDGE – INDUSTRIAL:

Industrial sludge is solid, semi-solid, or liquid residue generated during the treatment of industrial process wastewater in a treatment works; including, but not limited to, scum or solids removed in primary, secondary, or advanced wastewater treatment process; scum and solids filtered from water supplies and backwashed; and a material derived from industrial sludge.

- ✓ Not applicable; sludge is not generated by this industry.

SPILL REPORTING:

Any emergency involving a hazardous substance must be reported to the Department's 24 hour Environmental Emergency Response hotline at (573) 634-2436 at the earliest practicable moment after discovery. The Department may require the submittal of a written report detailing measures taken to clean up a spill. These reporting requirements apply when the spill results in chemicals or materials leaving the permitted property or reaching waters of the state. This requirement is in addition to the noncompliance reporting requirement found in Standard Conditions Part I. <https://dnr.mo.gov/waste-recycling/investigations-cleanups/environmental-emergency-response>.

Underground and above ground storage devices for petroleum products, vegetable oils, and animal fats may be subject to control under federal Spill Prevention, Control, and Countermeasure Regulation and are expected to be managed under those provisions, if applicable. Substances regulated by federal law under the Resource Conservation and Recovery Act (RCRA) or the Comprehensive Environmental Response, Compensation, and Liability Act (CERCLA) which are transported, stored, or used for maintenance, cleaning or repair shall be managed according to the provisions of RCRA and CERCLA.

STORMWATER POLLUTION PREVENTION PLAN (SWPPP):

In accordance with 40 CFR 122.44(k), BMPs must be used to control or abate the discharge of pollutants when: 1) Authorized under section 304(e) of the CWA for the control of toxic pollutants and hazardous substances from ancillary industrial activities; 2) Authorized under section 402(p) of the CWA for the control of stormwater discharges; 3) Numeric effluent limitations are infeasible; or 4) the practices are reasonably necessary to achieve effluent limitations and standards or to carry out the purposes and intent of the CWA. In accordance with the EPA's *Developing Your Stormwater Pollution Prevention Plan: A Guide for Construction Sites*, (Document number EPA 833-R-06-004) published by the EPA in 2007 https://www.epa.gov/sites/production/files/2015-10/documents/sw_swppp_guide.pdf, BMPs are measures or practices used to reduce the amount of pollution entering waters of the state from a permitted facility. BMPs may take the form of a process, activity, or physical structure. Additionally, in accordance with the Stormwater Management, a SWPPP is a series of steps and activities to 1) identify sources of pollution or contamination, and 2) select and carry out actions which prevent or control the pollution of storm water discharges. Additional information can be found in *Stormwater Management for Industrial Activities: Developing Pollution Prevention Plans and Best Management Practices* (EPA 832-R-92-006; September 1992).

A SWPPP must be prepared if the SIC code for the facility is found in 40 CFR 122.26(b)(14) and/or 10 CSR 20-6.200(2). A SWPPP may be required of other facilities where stormwater has been identified as necessitating better management.

The purpose of a SWPPP is to comply with all applicable stormwater regulations by creating an adaptive management plan to control and mitigate stream pollution from stormwater runoff. Developing a SWPPP provides opportunities to employ appropriate BMPs to minimize the risk of pollutants being discharged during storm events. The following paragraph outlines the general steps the permittee should take to determine which BMPs will work to achieve the benchmark values or limits in the permit. This section is not intended to be all encompassing or restrict the use of any physical BMP or operational and maintenance procedure assisting in pollution control. Additional steps or revisions to the SWPPP may be required to meet the requirements of the permit.

Areas which should be included in the SWPPP are identified in 40 CFR 122.26(b)(14). Once the potential sources of stormwater pollution have been identified, a plan should be formulated to best control the amount of pollutant being released and discharged by each activity or source. This should include, but is not limited to, minimizing exposure to stormwater, good housekeeping measures, proper facility and equipment maintenance, spill prevention and response, vehicle traffic control, and proper materials handling. Once a plan has been developed, the facility will employ the control measures determined to be adequate to prevent pollution from entering waters of the state. The facility will conduct inspections of the BMPs to ensure they are working properly and re-evaluate any BMP not achieving compliance with permitting requirements. For example if the BMP being employed is deficient in controlling stormwater pollution, corrective action should be taken to repair, improve, or replace the failing BMP. If failures do occur, continue this trial and error process until appropriate BMPs have been established.

The EPA has developed factsheets on the pollutants of concern for specific industries along with the BMPs to control and minimize stormwater (<https://www.epa.gov/npdes/stormwater-discharges-industrial-activities>). Along with EPA's factsheets, the International Stormwater BMP database (<https://bmpdatabase.org/>) may provide guidance on BMPs appropriate for specific industries.

For new, altered, or expanded stormwater discharges, the SWPPP shall identify reasonable and effective BMPs while accounting for environmental impacts of varying control methods. The antidegradation analysis must document why no discharge or no exposure options are not feasible. The selection and documentation of appropriate control measures shall serve as an alternative analysis of technology and fulfill the requirements of antidegradation [10 CSR 20-7.031(3)].

Alternative analysis evaluation of the BMPs is a structured evaluation of BMPs which are reasonable and cost effective. The alternative analysis evaluation should include practices designed to be: 1) non-degrading; 2) less degrading; or 3) degrading water quality. The glossary of the *Antidegradation Implementation Procedure* defines these three terms. The chosen BMP will be the most reasonable and effective management strategy while ensuring the highest statutory and regulatory requirements are achieved and the highest quality water attainable for the facility is discharged. The alternative analysis evaluation must demonstrate why "no discharge" or "no exposure" is not a feasible alternative at the facility. This structured analysis of BMPs serves as the antidegradation review, fulfilling the requirements of 10 CSR 20-7.031(3) Water Quality Standards and *Antidegradation Implementation Procedure*, Section II.B.

- ✓ Applicable: A SWPPP shall be developed and implemented for each site and shall incorporate required practices identified by the Department with jurisdiction, incorporate control practices specific to site conditions, and provide for maintenance and adherence to the plan.

UNDERGROUND INJECTION CONTROL (UIC):

The UIC program for all classes of wells in the State of Missouri is administered by the Missouri Department of Natural Resources and approved by EPA pursuant to section 1422 and 1425 of the Safe Drinking Water Act (SDWA) and 40 CFR 147 Subpart AA. Injection wells are classified based on the liquids which are being injected. Class I wells are hazardous waste wells which are banned by RSMo 577.155; Class II wells are established for oil and natural gas production; Class III wells are used to inject fluids to extract minerals; Class IV wells are also banned by Missouri in RSMo 577.155; Class V wells are shallow injection wells; some examples are heat pump wells and groundwater remediation wells. Domestic wastewater being disposed of sub-surface is also considered a Class V well.

In accordance with 40 CFR 144.82, construction, operation, maintenance, conversion, plugging, or closure of injection wells shall not cause movement of fluids containing any contaminant into Underground Sources of Drinking Water (USDW) if the presence of any contaminant may cause a violation of drinking water standards or groundwater standards under 10 CSR 20-7.031 or other health-based standards or may otherwise adversely affect human health. If the Department finds the injection activity may endanger USDWs, the Department may require closure of the injection wells or other actions listed in 40 CFR 144.12(c), (d), or (e). In accordance with 40 CFR 144.26, the permittee shall submit a Class V Well Inventory Form for each active or new underground injection well drilled, or when the status of a well changes, to the Missouri Department of Natural Resources, Geological Survey Program, P.O. Box 250, Rolla, Missouri 65402. Single family residential septic systems and non-residential septic systems used solely for sanitary waste and having the capacity to serve fewer than 20 persons a day are excluded from the UIC requirements (40 CFR 144.81(9)).

- ✓ Not applicable; this permit does not authorize subsurface wastewater systems or other underground injection. These activities must be assessed under an application for a site specific permit. Certain discharges of stormwater into sinkholes may qualify as UIC. It is important the permittee evaluate all stormwater basins, even those holding water; as sinkholes have varying seepage rates. This permit does not allow stormwater discharges into sinkholes. The facility must ensure sinkholes are avoided in the construction process. The State's online mapping resource <https://modnr.maps.arcgis.com/apps/webappviewer/index.html?id=87ebef4af15d438ca658ce0b2bbc862e> has a sinkhole layer.

VARIANCE:

Per the Missouri Clean Water Law Section 644.061.4, variances shall be granted for such period of time and under such terms and conditions as shall be specified by the commission in its order. The variance may be extended by affirmative action of the commission. In no event shall the variance be granted for a period of time greater than is reasonably necessary for complying with the Missouri Clean Water Law Section 644.006 to 644.141 or any standard, rule, or regulation promulgated pursuant to Missouri Clean Water Law Section 644.006 to 644.141.

- ✓ Not Applicable: This permit is not drafted under premises of a petition for variance.

WASTELOAD ALLOCATIONS (WLA) FOR LIMITATIONS:

Per 10 CSR 20-2.010(78), the amount of pollutant each discharger is allowed by the Department to release into a given stream after the Department has determined total amount of pollutant which may be discharged into the stream without endangering its water quality. Water quality based maximum daily and average monthly effluent limitations were calculated using methods and procedures outlined in USEPA's Technical Support Document For Water Quality-based Toxics Control (TSD) (EPA/505/2-90-001).

- ✓ Not applicable; water quality limitations were not applied in this permit.

WATER QUALITY STANDARDS:

Per 10 CSR 20-7.031(4), General Criteria shall be applicable to all waters of the state at all times, including mixing zones. Additionally, 40 CFR 122.44(d)(1) directs the Department to include in each NPDES permit conditions to achieve water quality established under Section 303 of the CWA, including state narrative criteria for water quality.

WHOLE EFFLUENT TOXICITY (WET) TEST:

Per 10 CSR 20-7.031(1)(FF), a toxicity test conducted under specified laboratory conditions on specific indicator organism; and per 40 CFR 122.2, the aggregate toxic effect of an effluent measured directly by a toxicity test. A WET test is a quantifiable method of determining if a discharge from a facility may be causing toxicity to aquatic life by itself, in combination with, or through synergistic responses when mixed with receiving water.

- ✓ Not applicable: At this time, permittees are not required to conduct a WET test. This permit is for stormwater only.

PART IV – EFFLUENT LIMITATIONS DETERMINATION

EPA Construction General Permit (CGP)

The CGP was used to research and support best professional judgment decisions made in establishing technology-based conditions for this general permit which are consistent with national standards. The permit writer determined the standards established by the CGP are achievable and consistent with federal regulations. Additionally, the conditions reflecting the best practicable technology currently available are utilized to implement the ELG.

In this general permit, technology-based effluent conditions are established through the SWPPP and BMP requirements. Effective BMPs should be designed on a site-specific basis. The implementation of inspections provides a tool for each facility to evaluate the effectiveness of BMPs to ensure protection of water quality. Any flow through an outfall is considered a discharge. Future permit action due to permit modification may contain new operating permit terms and conditions which supersede the terms and conditions, including effluent limitations, of this operating permit.

PART V–REPORTING REQUIREMENTS

SAMPLING:

The permittee is not required to sample stormwater under this permit. The Department may require sampling and reporting as a result of illegal discharges, compliance issues related to water quality concerns or BMP effectiveness, or evidence of off-site impacts from activities at the facility. If such an action is needed, the Department will specify in writing the sampling requirements, including such information as location and extent. If the permittee refuses to perform sampling when required, the Department may terminate the general permit and require the facility to obtain a site-specific permit with sampling requirements.

REPORTING:

There are quarterly reporting requirements for MO-R100xxx land disturbance permits. Project specific information is required to be report to the Department through the eDMR system.

PART VI – RAINFALL VALUES FOR MISSOURI & SURFACE WATER BUFFER ZONES

Knowledge of the 2-year, 24-hour storm event is used in this permit for two main reasons:

- 1) The design, installation, and maintenance of effective erosion and sediment controls to minimize the discharge of pollutants.
- 2) If the seven-day inspection frequency is utilized, an inspection must occur within 48 hours after any storm event equal to or greater than a 2-year, 24 hour storm has ceased.

For site-specific 2-year, 24-hour storm event information utilize the National Oceanic and Atmospheric Administration’s National Weather Service Atlas 14 (NOAA Atlas 14) which is located at https://hdsc.nws.noaa.gov/hdsc/pfds/pfds_map_cont.html. For more information visit; https://www.weather.gov/media/owp/oh/hdsc/docs/Atlas14_Volume8.pdf.

Surface Water Buffer Zones: In order to design controls that match the sediment removal efficiency of a 50-foot buffer, you first need to know what this efficiency is for your site. The sediment removal efficiencies of natural buffers vary according to a number of site-specific factors, including precipitation, soil type, land cover, slope length, width, steepness, and the types of erosion and sediment controls used to reduce the discharge of sediment prior to the buffer. For additional information;

https://www.epa.gov/sites/default/files/2017-02/documents/2017_cgp_final_appendix_g_-_buffer_reqs_508.pdf

PART VII – ADMINISTRATIVE REQUIREMENTS

On the basis of preliminary staff review and applicable standards and regulations, the Department, as administrative agent for the Missouri Clean Water Commission, proposes to issue a permit(s) subject to certain effluent limitations, schedules, and special conditions contained herein and within the permit. The proposed determinations are tentative pending public comment.

PUBLIC MEETING:

The department hosted three public meetings for this permit. The meetings were held on January 27, February 17, and March 9, 2021.

PUBLIC NOTICE:

The Department shall give public notice when a draft permit has been prepared and its issuance is pending. Additionally, public notice will be issued if a public hearing is to be held because of a significant degree of interest or because of water quality concerns related to a draft permit. No public notice is required when a request for a permit modification or termination is denied; however, the requester and facility must be notified of the denial in writing.

The Department must give public notice of a pending permit or of a new or reissued Missouri State Operating Permit. The public comment period is a length of time not less than thirty (30) days following the date of the public notice, during which interested persons may submit written comments about the proposed permit.

For persons wanting to submit comments regarding this proposed permit, please refer to the Public Notice page located at the front of this draft permit. The Public Notice page gives direction on how and where to submit appropriate comments.

- ✓ The Public Notice period for this permit is started March 25, 2022 and ended April 25, 2022. Two comment letters were received.

DATE OF FACT SHEET: 03/2/2022

COMPLETED BY:

SARAH WRIGHT

MS4 & LAND DISTURBANCE PERMITTING COORDINATOR

MISSOURI DEPARTMENT OF NATURAL RESOURCES

WATER PROTECTION PROGRAM

OPERATING PERMITS SECTION - STORMWATER AND CERTIFICATION UNIT

(573) 526-1139

Sarah.wright@dnr.mo.gov, dnr.generalpermits@dnr.mo.gov

Storm Water Pollution Prevention Plan



**Cole County, Missouri
Unincorporated Areas**

July 2012

Site Description

COLE COUNTY is located in central Missouri. It is bordered on the east by Osage County, the north by the Missouri River, the west by Moniteau County and the south by Miller County.

Population and Land Use

Cole County is 250,240 acres in size with an unincorporated urbanized area of 5,346 Acres. The county has a population of 72,757. The largest city is Jefferson City, with a population of 39,636. Approximately 8,796 people live in the urbanized area of unincorporated Cole County. (US Census, 2000).

Jefferson City is the home of the Lincoln University with 3,349 students. Other towns in Cole County include Wardsville (1,506), St. Martins (1,140), Taos (878), Russellville (807), Centertown (278), St. Thomas (263), and Lohman (163). (US Census 2010).

According to the 2007 US Agriculture Census, there are over 1,100 farms in Cole County with an average size of 164 acres. The total land used for farming is almost 180,840 acres.

Water Supply

Missouri-American Water Company – Missouri River; Cole County Public Water Supply District 1 – Wells; Cole County Public Water Supply District 2 – Wells; Cole County Water Supply District 3 – Wells; and Privately Owned Wells

Waste Water Treatment

City of Jefferson – Treatment Plant; Aqua-Missouri – Lagoons and Small Treatment Plants; and Individual On-Site Septic Systems

Watershed

North Moreau Creek to Moreau River to Missouri River; Grays Creek to Missouri River; and Wears Creek to Missouri River

Geologic Setting

Northern Edge of the Ozark Plateau – Bedrock is shallow bedded consisting of Ordovician carbonates

Average Rainfall

39.59 inches per year

Manufacturing

The County has the following manufacturing plants located with the urbanized areas:

1. Capital Quarries – Limestone Quarry Operations
2. Menu Maker Foods, Inc. – Food Packaging
3. Wren Enterprises – Security Hardware
4. J C Mattress Factory – Bedding Manufacturing

Best Management Practices

Temporary and Permanent Structural and Non-Structural BMPs

See Appendix A for a table outlining the temporary and permanent structural and non-structural best management practices that may be used in land disturbance activities.

Description of Best Management Practices

See Appendix B for descriptions of the best management practices that may be used in land disturbance activities.

Discharges to Valuable Resource Waters

Storm water discharges as described below shall be considered discharges to “valuable resource waters” and will not be allowed to have Total Settleable Solids in excess of 0.5 mg/L/hr.

- Storm water discharges within 1000 stream feet of:
 - Streams identified as a losing stream
 - Streams or lakes listed as an outstanding national or state resource water
 - Reservoirs or lakes used for public drinking water supplies
 - Streams, lakes, or reservoirs identified as critical habitat of endangered species
 - Streams, lakes, or reservoirs listed as impaired for sediment and/or unknown pollutants by standard MDNR methodology
- Storm water discharges:
 - Within 100 stream feet of a permanent stream (class P) or major reservoir (class L2)
 - Within two stream miles upstream of biocriteria reference locations
- Storm water discharges where:
 - Any of the disturbed area is defined as a wetland (class W), by CSR 20-7.031(1)(F)7
 - The storm water discharges to a sinkhole or other direct conduit to groundwater.

For the purpose of this SWPPP, the term “stream feet” shall mean the distance in feet following the nearest drainage channel from the land disturbance to the valuable resource water.

Disturbed Areas

- Slopes for disturbed areas must be defined for all projects.
- A site map or maps, defining the sloped areas must be included with all SWPPPs.
- Where soil disturbing activities cease in an area for 14 days or more, the contractor shall construct BMPs to establish interim stabilization
 - Interim stabilization consists of well established and maintained BMPs that are reasonable certain to protect waters of the state from sediment pollution.
- BMPs must be suited to the area disturbed, taking into account the drainage area, surfaces of drainage area, and steepness of slope.
- If the slope of the disturbed area is greater than 3:1 (H:V) or if the slope is greater than 3% and greater than 150 feet in length, then the contractor must establish interim stabilization within 7 days of ceasing operations on that part of the site.
- Delays in work caused by inclement weather or equipment malfunctions are not considered ceasing operations for the purpose of this section, as long as work resumes as soon as possible.

Installation

- Installation of all BMPs shall in accordance with the descriptions and details of that BMP as shown in Appendix B.
- Cole County will ensure the BMPs are properly installed at the locations and relative times specified in the SWPPP specific to that site.
- Peripheral or border BMPs to control runoff from disturbed areas shall be installed or marked for preservation before general site clearing is started. Storm water discharges from disturbed areas, which leave the site, shall pass through an appropriate impediment to sediment movement, such as a sedimentation basin, sediment traps, silt fences, etc. prior to leaving the land disturbance site.
- A drainage course change shall be clearly marked on a site map, included in the SWPPP specific to that site.

Sedimentation Basins

- The SWPPP for a specific site will require a sedimentation basin for each drainage area with 10 or more acres disturbed at one time.
- Sedimentation Basins shall be sized to contain a volume of at least 3600 cubic feet per each disturbed acre draining thereto.
- Accumulated sediment shall be removed from the basin as needed to ensure the minimum volume of 3600 cubic feet is maintained.
- Discharges from the basin shall not cause scouring of the banks or bottom of the receiving stream.
- The basin shall be maintained until final stabilization of the disturbed area served by the basin.
- Where the use of a sediment basin of this size is impractical, the SWPPP for a specific site will be allowed to use other similarly effective BMPs to be used to control erosion and sediment delivery. These similarly effective BMPs must:

- Be selected from BMPs allowed by this SWPPP
- Provide equivalent protection
- Both temporary and permanent sedimentation basins shall have a stabilized spillway to minimize the potential for erosion of the spillway or basin embankment.

Dewatering

Any dewatering practices that are to be employed on a specific site shall state in that site's SWPPP:

- Description of the method used
- Anticipated volume of water to be discharged
- Anticipated maximum flow rate of discharge (gpm)
- Method for treatment of the water from dewatering operations
 - For no reason shall water from discharging operations be discharged off site without treatment.

Roadways

- All efforts shall be made to prevent deposition of earth and sediment onto roadways through the use of proper BMPs.
- Where sediment is present on roadways, all storm water inlets shall have inlet protection.
- Where storm water will flow off the end of where a roadway terminates, a sediment catching BMP shall be provided
- Roadways and curb inlets shall be cleaned weekly or following a rainfall that generates runoff.
- Stabilized construction entrances shall be used to prevent sediment track out.

Amending/Updating the SWPPP

The SWPPP manager for the site shall amend and update the SWPPP as appropriate during the term of the land disturbance activity. The SWPPP manager shall amend the SWPPP, at a minimum, whenever the:

- Design, operation, or maintenance of BMPs is changed
- Design of the construction project is changed that could significantly affect the quality of the storm water discharges
- SWPPP manager's inspections indicate deficiencies in the SWPPP or any BMP
- MDNR notifies Cole County in writing of deficiencies in the SWPPP
- The SWPPP is determined to be ineffective in significantly minimizing or controlling erosion and sedimentation
- Total Settleable Solids from a storm water outfall exceed 2.5 mg/L/hr (or 0.5 mg/L/hr if discharged to a valuable resource water)
- MDNR determines violations of Water Quality Standards may occur or have occurred

Site Inspection Reports

- Inspections of the site of land disturbance activities shall occur at a minimum of:
 - Once per 7 calendar days
 - Within 48 hours of any rainfall that produces runoff on the site.
- For sites that have not been final stabilized, the following must occur for each inspection:
 - All installed BMPs and other pollution control measures shall be inspected for proper installation, operation and maintenance
 - All storm water outfalls shall be inspected for evidence of erosion or sediment deposition.
 - Receiving streams shall be inspected for 50 feet downstream of the outfall.
 - Any problems shall be noted in an inspection report and corrected within seven calendar days of inspection.
- The SWPPP Manager will be responsible for being aware of rain events that cause runoff on the site. Local weather reports should be viewed, or crews in the vicinity of the site should be consulted if the SWPPP manager does not report to the site regularly.
- If weather conditions make it impossible to correct the problems within seven days, a detailed report of the problem (including pictures), must be filed with the regular inspection reports.
- BMP malfunctions shall be corrected as soon as the weather conditions allow.
- Parts of the site that have been finally stabilized may be inspected once per month. (A once per month inspection schedule may be implemented for a site with interim stabilization if Boone County makes a written request for the schedule and it is approved by the Department)
- A log of each inspection shall be kept.
- The inspection report is to include the following minimum information:
 - Inspector's name
 - Date of inspection
 - Observations relative to the effectiveness of the BMPs
 - Actions taken or necessary to correct the problems
 - Listing of areas where land disturbance operations have permanently or temporarily stopped.
 - Signature of inspector

Proper Operation and Maintenance

Cole County shall at all times maintain all pollution control measures and systems in good order to achieve compliance with the terms of the general permit.

Typical Activities

The following are activities that are typically conducted by Cole County that may require a SWPPP. Some of these activities may need to meet additional requirement of MoDNR and/or other agencies.

Street/Road Construction/Removal
Land Clearing and Grading

Tree Clearing
Storm Sewer Construction/Removal
Bank Stabilization
Drainage Channel Construction/Rehab.
Building Construction/Removal
Parking Lot Construction/Removal
Bridge Construction/Removal
Fill Material Stockpiling (Soil and Rock)

SWPPP Management Personnel

The following Cole County Public Works personnel may be in charge of the management of the SWPPP for projects in Cole County. Other people not listed below may also be involved with the SWPPP of a specific project as employment conditions change. Please see the SWPPP for each particular site for details.

| | | | |
|---------------|------------------|----------------|----------------|
| Eric Landwehr | Brandon Boeckman | Spencer Coonce | Andy Myers |
| Matt Prenger | James Rademann | Brad Wyss | Kevin Bishop |
| Bryan Boyce | Gene Berhorst | Kevin Light | Mark Zimmerman |
| Aaron Lock | Brent Cain | | |

Appendix A

Temporary and Permanent Structural and Non-Structural BMPs

The following table lists the BMPs that can be expected to be used on projects requiring a Land Disturbance Permit

Construction Site Best Management Practices (BMPs)

| BMP No | Title | Environmental Category | | | | | | Use | |
|--------|--------------------------------------|------------------------|----------------------|-------------------|------------------|------------------|-----------|-----------|---|
| | | Erosion Control | Pollution Prevention | Runoff Management | Sediment Capture | Tracking Control | Temporary | Permanent | |
| EC-1 | Scheduling* | S | P | | | | | X | |
| EC-2 | Preservation of Existing Vegetation* | S | P | S | S | | | X | |
| EC-3 | Dust Control* | P | | | | | | X | |
| EC-4 | Hydraulic Mulch-bonded Fiber Matrix | P | | | | | | X | |
| EC-5 | Mulching* | P | | | | | | X | X |
| EC-6 | Seeding/Mulching* | P | | | | | | X | X |
| EC-7 | Sodding* | P | | | | | | X | X |
| EC-8 | Rolled Erosion Control Products | P | | | | | | X | X |
| EC-9 | Geotextiles and Plastic Covers | P | | | | | | X | X |
| EC-10 | Outlet/Energy Dissipation Devices | P | | | S | | | X | X |
| EC-11 | Temporary Stream Crossings | P | | | | | | X | |
| RM-1 | Check Dams | | | P | S | | | X | X |
| RM-2 | Earth Berms/Drainage Swales | | | P | | | | | X |
| RM-3 | Terracing | S | | P | S | | | | X |
| RM-4 | Slope Drains | S | | P | | | | X | |
| RM-5 | Soil Roughening* | S | | P | | | | X | |
| RM-6 | Fiber Rolls/Wattles | S | | P | S | | | X | |
| SC-1 | Vegetated Filter Strip* | S | | S | P | | | | X |
| SC-2 | Silt Fence | S | | S | P | | | X | |
| SC-3 | Straw Bale Dike | S | | S | P | | | X | |
| SC-4 | Compost Filter Socks | | | | P | | | X | |
| SC-5 | Compost Filter Berms | | | | P | | | X | |
| SC-6 | Sediment Basins | | | | P | | | X | |
| SC-7 | Sediment Traps | | | | P | | | X | |
| SC-8 | Curb and Gutter Inlet Protection | | | | P | | | X | |
| SC-9 | Drop Inlet Protection | | | | P | | | X | |
| TC-1 | Construction Entrance/Exit | | S | | | P | | X | |
| TC-2 | Washdown Station* | | S | | | P | | X | |
| PP-1 | Non-Sediment Pollution Control* | | P | | | | | X | |

P - Primary BMP function; S - Secondary function *Non-Structural

BMP Guidelines

Erosion and Sediment Control Measures

| BMP | Definition | Purpose | Where Applicable | Planning | Design Criteria |
|--|--|---|---|---|--|
| <p>Construction Sequence and Scheduling</p> | <p>A specified work schedule that coordinates the timing of land-disturbing activities and the installation of erosion and sedimentation control measures.</p> <p>The objective is to disturb only the immediate work areas.</p> | <p>To reduce on-site erosion and off-site sedimentation by performing land-disturbing activities and installing erosion and sediment control practices in accordance with a planned schedule.</p> | <p>All land-development projects that will disturb more than one contiguous acre.</p> | <p>The general order of construction and planning is:</p> <ul style="list-style-type: none"> • Plan disturbances to coincide with work progress. • Order materials to avoid delays. • Build construction site access. • Implement sediment traps and barriers. • Apply runoff control (diversions). • Implement main runoff conveyance system. • Build stream crossings. • Land clearing and grading. • Surface stabilization. • Building construction. • Landscaping and final stabilization. | <p>At a minimum, the construction sequence should include:</p> <ul style="list-style-type: none"> • Erosion and sedimentation control practices to be installed. • Principal development activities. • What measures should be in place before other activities begin. • Compatibility with the general construction schedule of the contract. <p>When changes in construction activities are needed, amend the sequence schedule as necessary to fit the changes.</p> |

Adapted from IECAs Tools for Rules: How to Select, Install and Inspect Construction Site BMPs for NPDES Compliance

BMP Guidelines

Erosion and Sediment Control Measures

| BMP | Definition | Purpose | Where Applicable | Planning | Design Criteria |
|---|---|---|---|---|---|
| <p>Protect Existing Vegetation</p> | <p>A construction management tool that retains site vegetation where possible by designating areas on which vegetation will not be disturbed.</p> | <p>Vegetation helps prevent soil erosion in the following ways:</p> <ul style="list-style-type: none"> • Roots hold soil together • Leaves and stems break up rainfall impact • Ground cover slows down runoff and filters sediment out of water • Plants evapotranspire water from soil. | <p>All land-development projects that will disturb more than one contiguous acre.</p> | <p>Conduct field survey to determine extent of development.</p> <p>Delineate areas of project where existing vegetation will be preserved.</p> <p>Provide a map outlining these areas to grading personnel.</p> | <p>At a minimum, areas of vegetation preservation should be shown on the grading map and instructions presented as to construction procedures to be followed in and around these sensitive areas, including:</p> <ul style="list-style-type: none"> • Placement of safety fence along the perimeter of protected zones • Routine inspection schedule for compliance • Remedial measures for repair and maintenance |

Adapted from IECAs Tools for Rules: How to Select, Install and Inspect Construction Site BMPs for NPDES Compliance

BMP Guidelines

Erosion Control Measures

| BMP | Definition | Purpose | Where Applicable | Planning | Design Criteria |
|----------------------------------|--|--|---|---|---|
| <p>Surface Roughening</p> | <p>Preparing the soil topography for the designed construction purpose while taking erosion and sediment control factors into consideration.</p> | <p>To leave the surface soil in a roughened condition to provide temporary soil stabilization and augment future erosion and sediment control practices.</p> | <p>To some extent, on most construction sites that require land disturbing activities, and in particularly where there are critical, erodible slopes.</p> | <p>Designate surface roughening practice based on site conditions and well as equipment availability.</p> | <p>Designing surface roughening techniques into the project is determined by:</p> <ol style="list-style-type: none"> 1. Site conditions 2. Available equipment (i.e. bulldozers, tractors, etc.) 3. Supplemental BMP application (i.e. hydraulic mulch, erosion control blanket, etc.) 4. Final landscape design. <p>Types of surface roughening techniques include:</p> <ul style="list-style-type: none"> • Track walking • Sheepsfoot rolling • Ripping • Imprinting |

Adapted from IECAs Tools for Rules: How to Select, Install and Inspect Construction Site BMPs for NPDES Compliance

BMP Guidelines

Erosion Control Measures

| BMP | Definition | Purpose | Where Applicable | Planning | Design Criteria |
|----------------------------------|--|--|--|--|--|
| Bench Terracing | Erosion control accomplished by constructing benches or large steps across the land slope. | Reduce the length of slope and thereby the potential for soil erosion. | On steep slopes where erosive factors are very high and gully erosion is likely to take place. | Terrace spacing and slope maintenance need to be considered. | Reduce slope length proportional to the steepness of the slope. Control outlets from terraces so erosion is eliminated. |
| Slope Interrupter Devices | Tube-like devices composed of a mesh or netting enclosing a biodegradable plant fiber that are installed on the slope contour. | To reduce runoff water velocities and trap sediment particles, thereby ameliorating the impact of slope length and steepness on erosion. | On slopes steeper than 5:1 | Follow manufacturer's instructions as to design and specification, particularly in terms of spacing. | Employ slope interrupter devices as a complementary practice to supplement: <ul style="list-style-type: none"> • Surface roughening techniques • Revegetation • Surface mulches, including hydraulic applications and rolled erosion control products • Removal after slope stabilized is optional |

Adapted from IECAs Tools for Rules: How to Select, Install and Inspect Construction Site BMPs for NPDES Compliance

BMP Guidelines

Erosion Control Measures

| BMP | Definition | Purpose | Where Applicable | Planning | Design Criteria |
|--|---|--|---|---|---|
| Temporary Seeding | Planting fast growing vegetation to provide temporary erosion control. | To provide stabilization on bare soil areas that will not be brought to final grade for a period of more than 30 working days. | May be used on cleared unvegetated areas where temporary erosion control is needed. | Selection of appropriate plant species, use of quality seed, proper bed preparation, and seed application method are important. | The area to be seeded should be uniform an loosened to a minimum depth of 3 inches. The area should be cleared of stones, roots and other debris. |
| Turf Reinforcement Materials (TRM) | Three-dimensional fabrics of synthetic materials placed in areas of concentrated flow to provide plant reinforcement. | To provide increased shear strength to allow plant material usage in drainage channels as a functional substitute for hard armoring. | Drainage channels, swales, slope drains and as separators between rip rap and underlying soil. | Follow manufacturer's recommendation as to design, specification and suitability of material for site. | Installation of TRMs is critical to their performance in the field. Follow manufacturer's recommendation as to design, specification and installation of the material in conjunction with its vegetative component. |
| Permanent Seeding/Planting of Grasses | Control of runoff and erosion with permanent vegetation. | To economically control erosion and sedimentation. | Used on graded or cleared areas where soil is unstable because of texture, structure, high water table, or slope. | Selection of appropriate plant species, use of quality seed, and proper bed preparation are important. | Planting should occur within 14 days of final grading. |

Adapted from IECAs Tools for Rules: How to Select, Install and Inspect Construction Site BMPs for NPDES Compliance

BMP Guidelines

Erosion Control Measures

| BMP | Definition | Purpose | Where Applicable | Planning | Design Criteria |
|---|--|--|--|--|--|
| <p>Topsoiling</p> | <p>Stripping off, storing, and spreading the upper layers of soil over disturbed areas.</p> | <p>To provide a suitable medium for vegetation establishment and growth.</p> | <p>Wherever it is economically practical, this technique should be considered. Recommended for use in areas where subsoil is infertile and other methods will not produce or maintain a desirable stand of vegetation.</p> | <p>Recommended for placement on soils that do not have a deep rooting zone to support plants, and that may contain material toxic to plant growth, and where exposed subsoil is not suitable to produce adequate vegetation.</p> | <p>Should be applied on slopes 2:1 or flatter.</p> <p>Sample topsoil or duff material and apply lime and fertilizer as appropriate.</p> |
| <p>Permanent Ground Cover Plants</p> | <p>Control of runoff and erosion with trees, vines and shrubs by stabilizing soils in areas where vegetation other than grasses or legumes is preferred.</p> | <p>To economically control erosion and sedimentation.</p> | <p>Used on steep banks, graded cleared areas, and shady areas where turf maintenance is difficult. Also, can be used between terraces.</p> | <p>Selection of species should match soil characteristics. Quality stock should be selected and kept moist form time of receipt and planted as soon as possible.</p> | <p>Usually more effective when planted in clumps or blocks. Competitive vegetation should be pulled out of the areas where the plants are to be planted.</p> |

Adapted from IECAs Tools for Rules: How to Select, Install and Inspect Construction Site BMPs for NPDES Compliance

BMP Guidelines

Erosion Control Measures

| BMP | Definition | Purpose | Where Applicable | Planning | Design Criteria |
|----------|--|--|--|--|---|
| Mulching | Use of a protective layer of straw, hay, wood chips, wood fibers, gravel, or synthetic materials on the soil surface to reduce rainfall impact and dislodgement of soil particles. | To protect the soil surface from the erosive forces of raindrop impact and overland or sheet flows. A secondary benefit of surface mulch is to retain soil moisture and moderate soil temperatures, aiding plant establishment. | As a temporary, non-vegetative surface erosion control treatment and/or in conjunction with a temporary or permanent re-vegetation technique, such as aerial or hydraulic seeding. | Application of temporary or permanent mulch materials should be planned to coincide with schedule of disturbance and final landscape design. | Organic mulches are most effective when uniformly spread and secured to the soil structure. <ul style="list-style-type: none"> • Cost • Longevity • Ease of installation • Erosion control effectiveness • Runoff vs. infiltration characteristics • Compatibility with revegetation strategy • Water quality impact Types of surface mulch materials/techniques include: <ul style="list-style-type: none"> • Straw or hay fibers • Paper or wood fibers • Gravel • Wood chips • Compost • Hydraulic matrices of cellulose fiber and tackifying agent • Bonded fiber matrices • Rolled erosion control products |

Adapted from IECAs Tools for Rules: How to Select, Install and Inspect Construction Site BMPs for NPDES Compliance

BMP Guidelines

Erosion Control Measures

| BMP | Definition | Purpose | Where Applicable | Planning | Design Criteria |
|----------------------------|--|---|---|--|--|
| Sodding | Use of grass sod to permanently stabilize an area. | To rapidly prevent erosion and sedimentation. | May be used in areas requiring immediate and permanent vegetative cover, particularly in landscaping applications. | More costly than seeding, but can be established during times of the year when grass seed may fail. Irrigation may be necessary. | On slopes, sod should be applied with the long dimension perpendicular to the slope and pegged or stapled sufficiently to prevent movement. |
| Riprap or Aggregate | Permanent layers of loose angular stones or aggregate with a filter fabric or granular underlining placed over an erodible soil surface. | To protect the soil surface from the erosive flow of water, slow water flow velocity, and stabilize slopes. | Used when soil may erode under design flow conditions and cannot be protected by vegetative cover or other means. Riprap can be used at: <ul style="list-style-type: none"> • Storm drain outlets, • Channel banks and bottoms, • Roadside ditches, • Drop structures, • Toe of slopes, • Channel transitions | Graded riprap contains a mixture of stone sizes while uniform riprap is made up of stones of similar sizes. <p>The size of stone used is directly related to the design flow velocity of the channel.</p> <p>Typically should be used for velocities in excess of 15 ft/sec.</p> | The minimum riprap thickness is 2 times the maximum stone diameter but not less than 6 inches. The specific gravity of the individual stones should be at least 2.5. <p>Maxim bank slope for application should not be steeper than 1.5:1.</p> |

Adapted from IECAs Tools for Rules: How to Select, Install and Inspect Construction Site BMPs for NPDES Compliance

BMP Guidelines

Erosion Control Measures

| BMP | Definition | Purpose | Where Applicable | Planning | Design Criteria |
|---------------------------------|---|--|--|--|--|
| <p>Outlet Protection</p> | <p>Structurally lined aprons or other acceptable energy dissipation devices placed at the outlets of pipes or paved channel sections.</p> | <p>To protect the soil surface from the erosive flow of water, slow the water flow velocity, and stabilize slopes or channels.</p> | <p>Used where the flow velocity at the design capacity will exceed the velocity of the receiving channel or area.</p> | <p>Geotextile fabrics in conjunction with vegetation create a natural outlet protection. Riprap aprons are relatively low cost and easy to install. Riprap stilling basins or plunge pools are used where overfalls exit the ends of pipes where high flows would require excessive apron lengths.</p> | <p>Capacity: 10-year peak runoff or design discharge of conveyance, whichever is greater.</p> <p>Geotextile fabrics should be designed to handle peak flow rates and tractive forces.</p> <p>The depth of a riprap apron should be 2 times the max. stone diameter but not less than 6 inches.</p> |
| <p>Dust Control</p> | <p>Actions or methods which reduce the erosive effects of wind on dry soils.</p> | <p>To prevent soil particles in the form of dust from becoming airborne.</p> | <p>Used where open dry areas of soil, particularly in dryer climates or during the dry season, are exposed to the erosive factors of the wind.</p> | <p>The direction of the prevailing winds and careful planning of clearing activities are important.</p> | <p>Minimize the period of soil exposure through use of temporary ground cover and other stabilization practices. Some possible dust control measures are:</p> <ul style="list-style-type: none"> • Vegetative cover, • Mulch or Stone • Spray-on adhesive • Calcium chloride • Sprinkling |

Adapted from IECAs Tools for Rules: How to Select, Install and Inspect Construction Site BMPs for NPDES Compliance

BMP Guidelines

Sediment Control Measures

| BMP | Definition | Purpose | Where Applicable | Planning | Design Criteria |
|--------------------------------|---|---|--|--|---|
| Sediment Basins | A suitably located temporary or permanent earthen embankment, barrier, dam, or excavated basin designed to capture sediment. | To retain sediment on the construction site and prevent sedimentation to off-site waterbodies, properties, etc. | Used where erosion control measures are not adequate to prevent off-site sedimentation on sites with disturbed area of 5 acres or more. | Hazard class must be considered so failure does not jeopardize property or lives. The location of the basin must be able to collect all of the site runoff. | Drainage area is between 5 and 150 acres. The flow length through the basin length to width ratio should be 2:1 or greater. |
| Temporary Sediment Trap | A small temporary ponding basin formed by constructing an embankment across a drainage swale, by excavating a pond or by rock fill. | To detain sediment-laden runoff from small, disturbed areas long enough to allow the majority of the sediment to settle out. | Used at the outlets of drains, diversions, channels, and other runoff conveyances. May be installed during early site development. | Access to trap must be maintained to periodically removed sediment for proper disposal. Structure life is limited to 18 months. | Used for drainage areas of 5 acres or less. Minimum storage area is fixed to meet 80% removal efficiency. Side slopes of the excavated trap should be 2:1 or flatter. Maximum height is 5 ft. |
| Silt Fence | Sediment barrier consisting of synthetic filter fabric stretched across posts with the bottom of the fabric being entrenched. In most cases the fabric should be reinforced with the support of a wire fence. | To catch and hold small amounts of sediment from disturbed areas by reducing the velocity of sheet flow to allow sediment deposition. | Used below small, disturbed areas less than 1/4 acre per 100 ft. of fence, and where runoff can be stored behind the fence without damaging the fence or the area behind it. | Should be located where shallow pools can be formed. Sediment deposition should be periodically removed and properly disposed of. Breaks in the fence should be used to minimize drainage areas. | Fence should be stable for the 10-yr storm. The slope should be no longer than 100 ft. and have a gradient of 2:1 or flatter. The minimum fabric height is 18 in. Maximum post spacing is 6 ft. Minimum post burial depth is 12 in. |

Adapted from IECAs Tools for Rules: How to Select, Install and Inspect Construction Site BMPs for NPDES Compliance

BMP Guidelines

Sediment Control Measures

| BMP | Definition | Purpose | Where Applicable | Planning | Design Criteria |
|---|---|--|--|--|--|
| Rock Ditch Checks | Small temporary dams constructed across a swale or drainage ditch to reduce the velocity of concentrated storm flows. | To reduce erosion of the channel by restricting the velocity of flow in the channel. Not to be installed in live channels or waters of the commonwealth. | Used as a temporary or emergency measure to limit erosion by reducing flow in a small open channel. | Ditch checks should not be used in live streams but are intended for temporary ditches and swales. Checks in grass channels may kill the vegetation. Ditch checks shall be promptly removed when their useful life has been completed. | Drainage area should not exceed 10 acres. The maximum height is 2 ft. at the center. The center should be at least 6 in. lower than the outer edges. The maximum spacing between checks should be such that the toe of the upstream check is at the same elevation as the top of the downstream check. The maximum size of stone used should be no greater than 8 in. in diameter. |
| Stabilized Construction Entrance | A gravel driveway or pad located at a point where vehicle enter and exit a construction site. | To reduce the amount of mud and soil transported onto public roads by traffic leaving the construction site. | Used wherever traffic leaves a construction site and enters a public right-of-way, street, alley, sidewalk, parking lot or other paved area. | Construction plans should limit all traffic to properly constructed entrances and exits. | Stone should be KTC #3 or larger. Pad thickness has a 6 in. minimum with a required geotextile fabric underlying the stone. The minimum width of the entrance shall be 24 ft. while the minimum length shall be 100 ft. |

Adapted from IECAs Tools for Rules: How to Select, Install and Inspect Construction Site BMPs for NPDES Compliance

BMP Guidelines

Sediment Control Measures

| BMP | Definition | Purpose | Where Applicable | Planning | Design Criteria |
|----------------------------------|--|--|---|--|--|
| Storm Drain Inlet Filters | A sediment filter or an excavated impounding area surrounding a storm drain inlet. | To retain sediment on the construction site by slowing and filtering runoff before it enters the storm drainage system. | Used where storm drain inlets are to be made operational before permanent stabilization of the disturbed area occurs. | <p>Must not be used near the edge of fill material and must not divert water over cut or fill slopes.</p> <ul style="list-style-type: none"> • Filter Fabric Inlet Protection • Stone Bag Inlet Protection • Block and Gravel Drop Inlet • Protection • Gravel and Wire Mesh Inlet • Sediment Filter | The drainage area must be no greater than 1 acre with a slope less than 5%. |
| Vegetated Filter Strips | Zones of vegetation through which sediment and pollutant-laden runoff are directed before being discharged to a concentrated flow channel. | Filter strips are used to remove sediment from overland sheet flow but are not effective in removing sediment from concentrated flows. | Used where runoff from land undergoing development needs to be filtered to reduce sediment damage to adjacent properties, streams or sinkholes. | Effectiveness can vary depending on vegetation, height, type and density, season of the year, soil eroded particle size characteristics, size of disturbed area, and site topography. | <p>The General Design Criteria are:</p> <p>Min. Width = 15 ft. Max. Ground Slope = 1% Max. Ground Slope = 10%.</p> |

Adapted from IECAs Tools for Rules: How to Select, Install and Inspect Construction Site BMPs for NPDES Compliance

BMP Guidelines

Temporary Flow Control and Conveyance Measures

| BMP | Definition | Purpose | Where Applicable | Planning | Design Criteria |
|------------------------------------|---|--|--|---|---|
| Temporary Pipe Slope Drains | Flexible tubing or conduit extending temporarily from the top to the bottom of a cut or fill slope. | To convey concentrated runoff down the face of a cut or fill slope to a protected stable area without causing erosion. | Used on sites before permanent stormwater drainage structures are installed and where stormwater runoff above a cut or fill slope will cause severe erosion if allowed to flow over the slope. | Must be sized, installed, and maintained properly because failure results in slope gully erosion. The entrance must be securely entrenched with watertight connections, with securely staked conduit. | Should handle peak runoff from the 10-yr storm. The maximum drainage area per pipe is 10 acres. The entrance should be constructed of a standard flared end section of pipe or equivalent. Reinforced hold-down garments should be spaced at 10 ft. or less intervals. |
| Runoff Control Measures | A temporary ridge, excavated channel, or combination ridge and channel constructed across sloping land at a pre-determined grade. | To divert clean water around work sites to stable outlets and to divert sediment-laden water to sediment control structures such as sediment traps and basins. | <ul style="list-style-type: none"> Above slopes to prevent clean runoff from flowing over unprotected soil. Across unprotected slopes to reduce flow lengths, Below slopes to divert runoff to a stable outlet, and Within and below disturbed areas to direct sediment-laden water to control structures. | Design as a stable channel with a mild bed slope. Use of either uniform or a gradually increasing grade is preferred over sudden decreases or increases in grade. A permanent vegetative covering is required where the channel grade is between 0.2% and 3%. | Design drainage area is 5 acres or less based on the peak runoff from the 10-yr. storm. A channel lining is required if the average velocity is greater than 2 ft/sec. Channel side slopes are 2:1 or flatter. The berm must have side slopes of 2:1 or flatter, with a minimum top width of 2 ft. and a designed freeboard of at least 4 in. |

Adapted from IECAs Tools for Rules: How to Select, Install and Inspect Construction Site BMPs for NPDES Compliance

BMP Guidelines

Permanent Flow Control and Conveyance Measures

| BMP | Definition | Purpose | Where Applicable | Planning | Design Criteria |
|--------------------------|--|---|--|--|---|
| Subsurface Drains | A perforated pipe or conduit placed beneath the surface of the ground at a designated depth and grade. | Used to drain saturated soils by lowering the water table. | Used in areas free from tree roots where the soil layer depth is deep enough to allow proper installation. | Not recommended in areas where the drain will pass under heavy vehicle crossings. | Should be designed for required capacity. The minimum diameter should be 6 in. The line should be graded to achieve at least a velocity of 2.4 ft/sec to prevent silting. |
| Level Spreader | Structure that converts sediment-free channel flow and uniformly releases it over a stabilized area. | Provides stable outlets for diversion channels, basins, dikes and other structures. | Used where sediment free storm runoff can be released as sheet flow over a stable area. | Install in areas where the level lip can be constructed without using fill material. The discharge area should have a maximum 10% slope and be well-vegetated and stable for design flow conditions. There should be no traffic across a level spreader. | Capacity determined by peak flow from the 10-yr. storm. The maximum desirable flow into the spreader should not exceed 30 cfs. Spreader length, width and depth are designed based on flow. There should be a 20 ft. long transition section between the channel entrance and the design width of the spreader. The grade of the spreader invert and lip must be 0. |

Adapted from IECAs Tools for Rules: How to Select, Install and Inspect Construction Site BMPs for NPDES Compliance

Appendix B

BMP Descriptions and Details

(Taken from Chapter 8 of the Boone County Storm Water Manual)



CHAPTER 8 EROSION AND SEDIMENT CONTROL

8.1 Introduction

These guidelines are intended to provide the designer, contractor and builder with design criteria and minimum standards for the installation of erosion and sediment controls to comply with the Erosion and Sediment Control Regulations. The regulations were enacted to protect the health, safety, and property of the citizens and to help protect area water resources from pollution due to erosion and transportation of sediment. The regulations are applicable to all land development and land disturbance activity within the regulated MS4 area where the area of disturbance is more than one acre. The regulations require that no person cause or allow sediment to be deposited in any public street, public land, or on any property not under their control as a result of land disturbance from construction activities.

You can comply with the regulations by meeting the following objectives:

- a. Minimize the area disturbed by construction and development;
- b. Provide for containment of sediment until areas are stabilized;
- c. Stabilize disturbed areas as soon as practical after project completion; and
- d. Provide permanent erosion, drainage, and detention controls.

8.2 General Design Guidelines

Erosion is a natural process where soil and rock are loosened and removed. Natural erosion normally occurs at a very slow pace, but when land is disturbed by vegetation removal, grading and other construction activities, the erosion rate often increases dramatically. When erosion occurs on a construction site the sediment is available for transport by either wind or stormwater runoff. The discharge of sediment and other construction site pollutants can negatively impact downstream water quality.

The purposes of erosion and sediment controls are to minimize the amount of erosion that occurs as a result of construction activities and to prevent the sediment from leaving the property. Effective erosion and sediment control requires that the soil surface be protected from the erosive forces of wind, rain, and runoff and that the eroded soil be captured and retained onsite.

When designing sediment and erosion controls, it is necessary to determine whether there is **sheet flow** or **concentrated flow** of stormwater on the property. Sheet flow occurs on gently sloping land without defined drainage ways. The stormwater tends to disperse evenly across the property, although the drainage may be in one direction due to the overall slope. Concentrated flow occurs where there are defined drainage ways that may range from gentle swales to clearly defined waterways. It is possible to have a combination of sheet flow and concentrated flow on the same property.



1. Erosion Protection

Proper planning will help identify potential erosion problems, particularly highly susceptible areas, such as areas of concentrated flow. Removing the vegetative cover and altering the soil structure by clearing, grading and compacting the surface increases an area's susceptibility to erosion. Scheduling can be a very effective means of reducing erosion by minimizing both the exposed area and the duration of exposure. Apply stabilizing measures as soon as possible after the land is disturbed. Plan and implement temporary or permanent vegetation, mulches, or other protective practices to correspond with construction activities. Protect channels from erosion forces by using protective linings and the appropriate channel design. Consider possible future repairs and maintenance of these practices in the design. In scheduling, take into account the season and the weather forecast.

Clearing existing vegetation reduces the surface roughness and infiltration rate and increases runoff velocities and volumes. This is particularly a concern in areas of concentrated flow. Use measures that break the slopes to reduce the problems associated with concentrated flow volumes and runoff velocities. Practical ways to reduce velocities include conveying stormwater runoff away from steep slopes to stabilized outlets, preserving natural vegetation where possible, and mulching and vegetating exposed areas immediately after construction.

2. Sediment Containment

Even with careful planning some erosion is unavoidable, and the resulting sediment must be trapped on the site. In areas where runoff occurs primarily as sheet flow, containment of sediment is relatively simple. In these areas, temporary containment devices may be sufficient. Where concentrations of flow occur, containment of sediment becomes more difficult as the rate and volume of flow increase. In these areas, more extensive or permanent control devices need to be provided. Areas of steep topography and cut or fill slopes need to be given special consideration. Due to the environmental sensitivity of streams, rivers, losing streams, sinkholes, and other Karst topographic features, special consideration also needs to be given to these areas. Plan the location where sediment deposition will occur and maintain access for periodic removal of accumulated sediment. Protect low points below disturbed areas by building barriers to reduce sediment loss. Sediment traps and basins should be constructed before other land-disturbing activities occur.

3. Temporary versus Permanent Controls

Temporary controls, such as straw bale dikes, silt fences, erosion control blankets, etc., are provided for the purpose of controlling erosion and containing sediment until construction is complete. Temporary controls are not needed after the area is stabilized.

Permanent controls consist of riprap, detention basins, etc., which will remain in place through the life of the development. It is possible for the same facility to serve both a temporary and permanent purpose.



4. Maintenance

Regular inspection and maintenance of Best Management Practices (BMPs) are vital to the performance of erosion and sedimentation control measures. If not properly maintained, some practices may cause more damage than they prevent. Always evaluate the consequences of a measure failing when considering which control measure to use, since failure of a practice may be hazardous or damaging to both people and property. For example, a failure of a large sediment basin can have disastrous results, and low points in dikes can cause major gullies to form on a fill slope. It is essential to inspect all practices to determine that they are working properly and to ensure that problems are corrected as soon as they develop.

8.3 BMP Descriptions and Design Guidance

The following principles are effective when they are integrated into a system of control practices and management techniques to control erosion and prevent sedimentation offsite. As a matter of practicality, proprietary erosion and sediment control products are not specifically identified herein. However, the County encourages the use of these products when designed, specified and installed in accordance with manufacturer's recommendations. Sufficient details related to these products should be supplied to facilitate the review of the plans to ensure the suitability of the practice. The following is not meant to provide an exhaustive list of all acceptable erosion and sediment control practices accepted by the county, only as a general guidance document.

There may be instances where certain erosion control designs are beyond the scope of general civil engineering knowledge. Specifically, natural stream stabilization and/or restoration should only be done with specific expertise and experience with these systems. This manual is not intended to convey such a level of knowledge and therefore will not address this level of complexity.

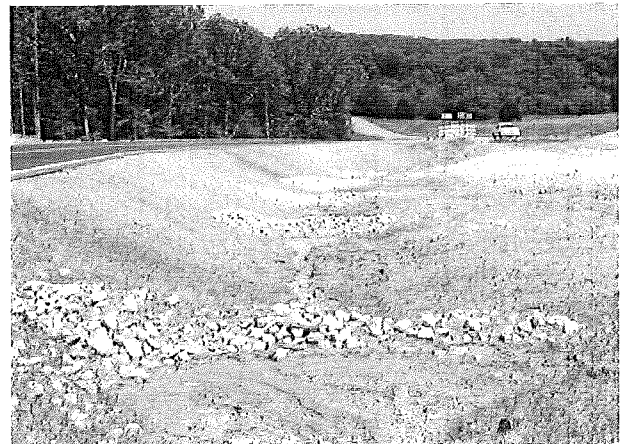
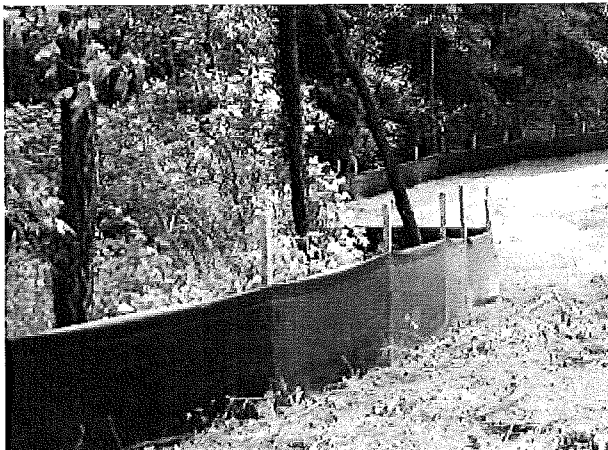

Figure 1. Silt Fences are placed at the perimeter of the job site to capture and prevent sediment from leaving the site.

Figure 2. Rock Check dams can reduce water velocities in areas of channelized flow.



EC-1 SCHEDULING

This BMP involves developing a schedule that includes sequencing of construction activities with the implementation of construction site BMPs such as temporary soil stabilization (erosion control) and temporary sediment control measures for every project. The purpose is to reduce the amount and duration of soil exposed to erosion by wind, rain, runoff and vehicle tracking, and to perform the construction activities and control practices in accordance with the planned schedule.

APPROPRIATE APPLICATIONS:

Construction sequencing shall be scheduled to minimize land disturbance for all projects at all times.

CONDITIONS FOR EFFECTIVE USE:

All land disturbing activities.

WHEN BMP IS TO BE INSTALLED:

Scheduling should take place during the planning stages and be modified throughout the duration of the project.

STANDARDS AND SPECIFICATIONS:

Developing a schedule and planning the project are the very first steps in an effective storm water program. The construction schedule shall be incorporated into the SWPPP. Develop the sequencing and timetable for the start and completion of each item such as site clearing and grubbing, grading, excavation, paving, pouring foundations, installing utilities, etc., to minimize the active construction area during the rainy season. Schedule major grading operations for the non-rainy season when practical. Incorporate staged seeding and re-vegetation of graded slopes as work progresses. Consider the appropriate planting time for specified vegetation when establishing permanent vegetation.

OPERATION AND MAINTENANCE PROCEDURES:

Verify that work is progressing in accordance with the schedule. If progress deviates, take corrective actions. Amend the schedule when changes are warranted.

EC-2 PRESERVATION OF EXISTING VEGETATION

Preservation of existing vegetation is the identification and protection of desirable vegetation that provides erosion and sediment control benefits and includes establishing setbacks to protect stream banks according to the County stream buffer regulations.

APPROPRIATE APPLICATIONS:

Preserve existing vegetation at areas on a site where no construction activity is planned or will occur at a later date.



CONDITIONS FOR EFFECTIVE USE:

Protection of existing vegetation requires planning, and may limit the area available for construction activities.

WHEN BMP IS TO BE INSTALLED:

Existing vegetation to be preserved shall be identified on the plans. Measures to protect said vegetation (such as construction fencing and signage) should be installed prior to the commencement of clearing and grubbing operations or other soil-disturbing activities.

STANDARDS AND SPECIFICATIONS:

Minimize the disturbed areas by locating temporary roadways to avoid stands of trees and shrubs and to follow existing contours to reduce cutting and filling. Mark areas to be preserved with temporary fencing at least 3.2 ft. tall. The fence post spacing and depth shall be adequate to completely support the fence in an upright position. Construction materials, equipment storage, and parking areas shall be located where they will not cause root compaction. Keep equipment away from trees to prevent trunk and root damage. Employees and subcontractors shall be instructed to honor protective devices. No heavy equipment, vehicular traffic, or storage piles of any construction materials shall be permitted within the drip line of any tree to be retained. Trenching shall be as far away from tree trunks as possible, usually outside of the tree drip line or canopy. The ends of damaged or cut roots shall be cut off smoothly.

OPERATION AND MAINTENANCE PROCEDURES:

During the construction phase(s), limits of disturbance shall remain clearly marked at all times. If damage to protected trees occurs, the injured tree shall be attended to by an arborist.

SITE CONDITIONS FOR REMOVAL:

Temporary fencing shall be removed after final stabilization of the site has occurred.

EC-3 DUST (WIND EROSION) CONTROL

Wind erosion control consists of applying water and/or other dust palliatives as necessary to prevent or alleviate erosion by the forces of wind. Alternatives to applying water or other dust palliatives include mulch or vegetative cover, wind barriers, and minimization of soil disturbance.

APPROPRIATE APPLICATIONS:

This practice is implemented on all exposed soils subject to wind erosion.

CONDITIONS FOR EFFECTIVE USE:

Effectiveness depends on soil, temperature, slope, aspect, humidity and wind velocity.

WHEN BMP IS TO BE INSTALLED:



Dust control should be performed routinely, especially in advance of and during periods of dry weather.

STANDARDS AND SPECIFICATIONS:

Water shall be applied by means of pressure-type distributors or pipelines equipped with a spray system or hoses and nozzles that will ensure even distribution. Phase work to the extent practical to minimize concurrent areas of soil disturbance. For areas not subjected to traffic, vegetation provides the most practical method of dust control and should be established as early as possible. Wind barriers such as solid board fences, snow fences, burlap fences, crate walls, and similar materials can be used to control air currents and blowing soil. Barriers placed at right angles to prevailing wind currents at intervals of about 10 times their height are effective in controlling soil blowing. Paved areas that have soil on them from construction sites should be cleaned regularly. Mulching offers a fast and effective means of controlling dust when properly applied. Binders and tackifiers may need to be used on organic mulches. NOTE: If calcium chloride or spray-on adhesives are used for dust control, a permit may be required from MoDNR.

OPERATION AND MAINTENANCE PROCEDURES:

Check areas that have been protected to ensure coverage.

SITE CONDITIONS FOR REMOVAL:

Dust control should be implemented when soils are exposed until cover is established.

EC-4 HYDRAULIC MULCH-BONDED FIBER MATRIX

Hydraulic mulch consists of applying a mixture of shredded wood fiber or a hydraulic bonded fiber matrix (BFM) and a stabilizing emulsion or tackifier with hydroseeding equipment, which temporarily protects exposed soil from erosion by raindrop impact or wind. BFMs adhere directly to the soil, eliminating gaps between the product and the soil. A water-insensitive crust does not form; therefore plant growth is not inhibited. Mulch and BFMs will biodegrade completely into material beneficial to plant growth. Seed may be applied simultaneously with mulching.

APPROPRIATE APPLICATIONS:

Hydraulic mulch and BFMs are applied to disturbed areas requiring temporary protection until permanent vegetation is established or disturbed areas that must be re-disturbed following an extended period of inactivity.

CONDITIONS FOR EFFECTIVE USE:

Type of Flow: Sheet flow only.

Wood fiber hydraulic mulches and BFMs are generally short-lived (only last part of a growing season) and need 24 hours to dry before rainfall occurs to be effective.



WHEN BMP IS TO BE INSTALLED:

Hydraulic mulch or bonded fiber matrix should be applied immediately after completion of a phase of grading.

STANDARDS AND SPECIFICATIONS:

Follow manufacturer's recommendations to maximize usefulness. Avoid mulch over-spray onto the traveled way, sidewalks, and lined drainage channels. Materials for wood fiber-based hydraulic mulches and bonded fiber matrices shall meet environmental quality standards and not be a detriment to stormwater discharges from the site.

OPERATION AND MAINTENANCE PROCEDURES:

Inspect at least every week and after every storm until vegetation is fully established. Repair eroded areas and reapply product and vegetation.

SITE CONDITIONS FOR REMOVAL:

Typically these materials are left in place to degrade naturally.

EC-5 MULCHING

A layer of organic material designed to protect exposed soil or freshly seeded areas from erosion by eliminating direct impact of precipitation and slowing overland flows. Mulch materials may include, but are not limited to, grass, hay, straw, wood chips, wood fibers, and shredded bark.

APPROPRIATE APPLICATIONS:

Typically used for soil stabilization as a temporary surface cover on disturbed areas until soils can be prepared for revegetation and permanent vegetation is established. Mulch can also be installed in land--scape areas for permanent use.

CONDITIONS FOR EFFECTIVE USE:

Type of Flow: Sheet flow only

The use of appropriate mulch will help ensure the vegetation is established under normal conditions and is essential to seeding success under harsh site conditions. General mulch recommendations to protect from raindrop splash and sheet flow include: straw applied at 2-2.5 tons/acre, wood fiber or wood cellulose applied at 0.5-1 ton/acre, wood chips applied at 5-6 tons/acre, and bark applied at 35 yd³/acre. Where slopes are 25 percent (4:1) or greater, hydromulch, bonded fiber matrix, or erosion control blankets are required.

WHEN BMP IS TO BE INSTALLED:

Mulch should be applied immediately after grading landscaped areas or seeding other areas.

STANDARDS AND SPECIFICATIONS:



Install upstream BMPs to protect area to be mulched. Rough grade area and remove all debris larger than 1 inch if area is to be vegetated and mowed in the future, larger than 2 inches if area is to be permanently mulched. If area is to be seeded, follow requirements of Seeding BMP. Spread mulch evenly.

OPERATION AND MAINTENANCE PROCEDURES:

Inspect at least every week and after every storm until adequate vegetation is established; annually for permanent mulch. Protect from vehicular and foot traffic. Repair damaged, degraded or eroded areas-reseed as needed and replace mulch.

EC-6 SEEDING/MULCHING

Establishment of vegetation by spreading grass seed designed to protect exposed soil from erosion by eliminating direct impact of precipitation and slowing overland flow rates. Once established, the vegetative cover will also filter pollutants from the runoff.

APPROPRIATE APPLICATIONS:

Exposed soil after a phase of rough or finish grading has been completed, or areas where no activity will occur for 14 days.

CONDITIONS FOR EFFECTIVE USE:

Type of Flow: Sheet flow and concentrated flow (additional stabilization is necessary).

Minimum Rates: Permanent seeding should consist of 90% tall fescue and 10% annual ryegrass. Seed mixture should be applied at 400 pounds/acre. Temporary seeding shall consist of any combination of tall fescue, annual ryegrass, millet, wheat or oats. Seed mixture should be applied at 200 pounds/acre. Dormant season seeding, seed mix should consist of 80% tall fescue, 10% annual ryegrass and 10% spring oats. Seed mixture is to be applied at 600 pounds/acre.

Acceptable Dates: Permanent seeding may be done March 1 to June 1 and August 15 to November 1. Temporary seeding can occur during any season, however winter is the least tolerant. Dormant season seeding includes December 15 to February 29.

WHEN BMP IS TO BE INSTALLED:

Seed and mulch should be applied immediately after rough or finished grading is completed.

STANDARDS AND SPECIFICATIONS:

Install upstream BMPs to prevent erosion and protect the area to be seeded. Complete grading and remove all debris larger than 1 inch. Loosen compacted soils to a depth of 4 inches. Groove or furrow on the contour if necessary. Spread loose topsoil at a depth of 4 inches.

Soil amendments should be applied per soil tests. When these are not available, lime shall be applied at the rate of 1500 pounds effective neutralizing material per acre. Soils with a pH of six



or higher need not be limed. When soil tests are not available, a 13-13-13 grade fertilizer shall be applied at a rate of 500 pounds/acre for permanent seeding and a 10-10-10 grade fertilizer shall be applied at the rate of 200 pounds/acre. Mix soil amendments (lime, fertilizer, etc.) into the top 4 inches of soil.

Plant seed $\frac{1}{4}$ to $\frac{1}{2}$ inches deep using a cyclone seeder, drill, cultipacker seeder, or hydro-seeder. Roll lightly to firm surface. Cover seeded area with mulch. Install additional stabilization (erosion control blankets, netting, bonded fiber matrix, etc.) on slopes steeper than 3:1 and in areas of concentrated flow. Water seeded area immediately. Provide enough water to soak 4 inches into the soil without causing runoff.

OPERATION AND MAINTENANCE PROCEDURES:

Inspect at least weekly and after every storm. Protect seeded areas from vehicular and foot traffic. Reseed and mulch areas that have not sprouted within 21 days of planting. Repair damaged or eroded areas and reseed/mulch and stabilize as needed. Do not mow until 4 inches of growth occurs. During the first 4 months, mow no more than $\frac{1}{3}$ the grass height.

EC-7 SODDING

Sod consists of a $\frac{3}{4}$ inch to 1 inch mat of vigorous turf, free from disease, insects and weeds. Sod prevents raindrops from disrupting the soil structure and causing erosion. Sod slows water runoff and acts as a filter when sediment laden runoff crosses over the sodded area.

APPROPRIATE APPLICATIONS:

Typically installed in areas requiring immediate erosion protection, such as swales or detention ponds and as filter strips, around inlets, and adjacent to curbs. Also installed in areas requiring immediate aesthetic appearance or function such as entrances to new subdivisions and off site construction areas.

CONDITIONS FOR EFFECTIVE USE:

Type of Flow: Sheet flow and low concentrated flows with velocities less than 5 fps.

WHEN BMP IS TO BE INSTALLED:

Sod should be installed immediately after finish grading, installation of area inlets, and installation of underground services and foundations of new homes.

STANDARDS AND SPECIFICATIONS:

Rough grade area and remove all debris larger than $\frac{1}{2}$ inch in diameter and concentrated areas of smaller debris. Soil preparation of area to be sodded shall be determined by tests to determine lime and fertilizer requirements. Scarify soil and level to provide an even grade. Soil should not be excessively wet or dry. Lay first row of sod perpendicular to the slope or direction of flow. Butt subsequent rows tight against previous rows with strips staggered in brick-like pattern. Fill minor gaps with good soil and roll entire surface to ensure contact. Stake, staple and/or net



corners and centers of sod strips as required, especially areas of concentrated flow. Water should be applied immediately after installation of sod. Provide enough to soak 4 inches into the soil without causing runoff.

OPERATION AND MAINTENANCE PROCEDURES:

Water sod daily for 3 weeks, enough to soak 4 inches into the soil without causing runoff. Reposition areas of sod that have moved along the slope. Remove sediment accumulations, replace sod if necessary. Repair any eroded areas, replace sod, and stabilize as needed. Do not mow until 3 inches of new growth occurs. During the first 4 months, mow no more than 1/3 the grass height.

EC-8 ROLLED EROSION CONTROL PRODUCTS

Rolled erosion control products include erosion control blankets and turf reinforcement mats. Erosion control blankets are pre-formed protective blanket of plastic fibers, wood fibers, straw or other plant residue designed to protect soil from the impact of precipitation and overland flow, and retain moisture to facilitate establishment of vegetation. Turf reinforcement mats include netting designed to anchor the root system of the vegetation growing through it.

APPROPRIATE APPLICATIONS:

These products may be installed on seeded areas for temporary or permanent use.

CONDITIONS FOR EFFECTIVE USE:

Several factors, such as soil conditions, steepness and length of slope, depth of flow, runoff velocities, and time required to establish desired vegetation, influence the choice of product. Manufacturer's recommendations should be followed. Products are available for a variety of uses: Netting-synthetic or natural fiber mesh installed over disturbed areas to hold organic mulch and/or seed in place, Biodegradable Erosion Control Blanket-natural fiber blanket held together by netting to provide temporary erosion protection on slopes and channels, and Permanent Erosion Control Blanket-synthetic blanket material which provides permanent erosion control on slopes and channels with increased water flow velocities.

WHEN BMP IS TO BE INSTALLED:

Rolled erosion control products should be installed immediately after completion of a phase of grading or installation of vegetation.

STANDARDS AND SPECIFICATIONS:

Follow manufacturer's recommendations and specifications, particularly noting requirements for check slots, fastening devices and need for firm contact with soil.

OPERATION AND MAINTENANCE PROCEDURES:



Inspect at least every week and after every storm until adequate vegetation is established. Repair erosion and/or undermining at top of slope. Repair undermining beneath blankets-pull back the blanket(s), fill compact eroded area, re-vegetate and then firmly secure the blanket(s). Reposition or replace blanket(s) that have moved along the slope or have been damaged.

SITE CONDITIONS FOR REMOVAL:

Temporary blankets will generally degrade naturally; permanent blankets remain in place.

STANDARD DRAWING: EC-8a and EC-8b

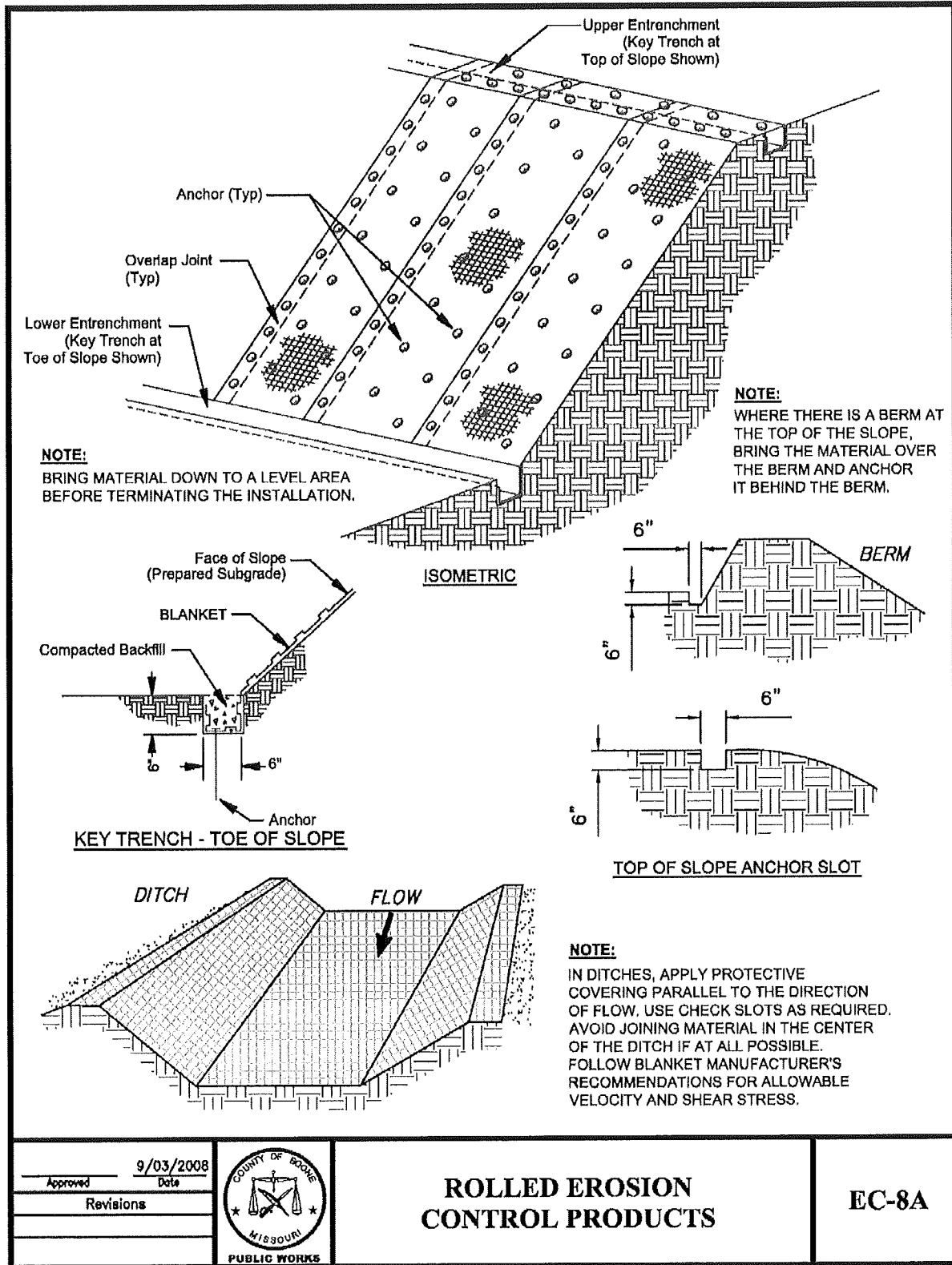



EROSION CONTROL BLANKET NOTES:

A) SITE PREPARATION:

AFTER SITE HAS BEEN SHAPED AND GRADED, PREPARE A FRIABLE SEEDBED RELATIVELY FREE FROM CLODS AND ROCKS MORE THAN 1 1/2 INCHES IN DIAMETER AND ANY FOREIGN MATERIAL THAT WILL PREVENT UNIFORM CONTACT OF THE BLANKET WITH THE SOIL SURFACE.

B) PLANTING:

LIME, FERTILIZE, AND SEED IN ACCORDANCE WITH SEEDING OR PLANTING PLAN. WHERE GROUND COVERS ARE TO BE PLANTED, LAY THE PROTECTIVE COVERING FIRST AND THEN PLANT THROUGH THE MATERIAL AS PER PLANTING PLAN.

C) LAYING AND STAPLING:

1. START LAYING THE BLANKET FROM THE TOP OF THE CHANNEL OR SLOPE AND UNROLL DOWN-GRADE. ALLOW TO LAY LOOSELY ON SOIL; DO NOT STRETCH.
2. UPSLOPE ENDS OF THE BLANKET SHOULD BE BURIED IN AN ANCHOR SLOT NO LESS THAN 6-INCHES DEEP. TAMP EARTH FIRMLY OVER THE MATERIAL.
3. WHERE MULTIPLE WIDTHS ARE LAID SIDE BY SIDE, THE ADJACENT EDGES SHALL BE OVERLAPPED A MINIMUM OF 6 INCHES AND STAPLED TOGETHER.
4. STAPLES SHALL BE PLACED PER MANUFACTURER'S RECOMMENDATIONS.

D) TROUBLESHOOTING:

- CONSULT WITH THE ENGINEER, IF ANY OF THE FOLLOWING OCCUR:
1. MOVEMENT OF THE BLANKET OR EROSION UNDER THE BLANKET IS OBSERVED.
 2. VARIATIONS IN TOPOGRAPHY ON SITE INDICATE EROSION CONTROL MAT WILL NOT FUNCTION AS INTENDED; CHANGES IN PLAN MAY BE NEEDED, OR A BLANKET WITH A SHORTER OR LONGER LIFE MAY BE NEEDED.
 3. DESIGN SPECIFICATIONS FOR SEED VARIETY, SEEDING DATES, OR EROSION CONTROL MATERIALS CANNOT BE MET; SUBSTITUTION MAY BE REQUIRED. UNAPPROVED SUBSTITUTIONS COULD RESULT IN FAILURE TO ESTABLISH VEGETATION.

E) MAINTENANCE & INSPECTION:

INSPECT CONTROLS AFTER EACH RAIN EVENT OF 1/2 INCH OR GREATER, AND EVERY 7 DAYS UNTIL VEGETATION IS ESTABLISHED. LOOK FOR EROSION OR UNDERMINING BENEATH THE NETTING, BLANKETS, OR MATS. IF ANY AREA SHOWS EROSION, PULL BACK THAT PORTION OF THE MATERIAL, ADD SOIL, AND RESEED; RESECURE THE MATERIAL IN PLACE. IF NETTING, BLANKETS OR MATS BECOME DISLOCATED OR DAMAGED, REPAIR OR REPLACE AND RESECURE IMMEDIATELY.

F) JOINING BLANKETS:

OVERLAP THE END OF THE PREVIOUS ROLL A MINIMUM OF 6 INCHES AND STAPLE. STAPLE ACROSS THE END OF THE ROLL JUST BELOW THE ANCHOR SLOT AND ACROSS THE MATERIAL EVERY 6 INCHES.

G) TERMINAL END:

AT THE POINT AT WHICH THE MATERIAL IS DISCONTINUED, OR WHERE THE BLANKET MEETS A STRUCTURE OF SOME TYPE, STAPLE A MINIMUM OF EVERY 12 INCHES.

H) FINAL CHECK:

- THESE INSTALLATION CRITERIA MUST BE ADHERED TO:
1. ALL DISTURBED AREAS ARE SEEDED.
 2. PROTECTIVE BLANKET IS IN UNIFORM CONTACT WITH THE SOIL.
 3. ALL LAP JOINTS ARE SECURE.
 4. ALL STAPLES ARE DRIVEN FLUSH WITH THE GROUND.

| | | | | | | | | | | | |
|---|-----------|-----------|-----------|------|--|--|--|--|---|---|---------------------|
| <table border="1"> <tr><td>Approved</td><td>9/03/2008</td></tr> <tr><td>Revisions</td><td>Date</td></tr> <tr><td> </td><td> </td></tr> <tr><td> </td><td> </td></tr> </table> | Approved | 9/03/2008 | Revisions | Date | | | | |  | <p>ROLLED EROSION CONTROL PRODUCTS</p> | <p>EC-8B</p> |
| Approved | 9/03/2008 | | | | | | | | | | |
| Revisions | Date | | | | | | | | | | |
| | | | | | | | | | | | |
| | | | | | | | | | | | |



EC-9 GEOTEXTILES AND PLASTIC COVERS

This Best Management Practice (BMP) involves the placement of geotextiles or plastic covers to stabilize disturbed soil areas and protect soils from erosion by wind or water.

APPROPRIATE APPLICATIONS:

Limited applications include very small graded areas and stockpiles.

CONDITIONS FOR EFFECTIVE USE:

Type of Flow: Sheet and concentrated flows.

Geotextiles and plastic covers have maximum flow rate limitations; consult the manufacturer for proper selection. The use of plastic shall be limited to very short periods of time. The use of plastics and impermeable geotextiles results in 100% runoff, which may cause serious erosion problems in the areas receiving the increased velocities and flow. Use these products with caution. Plastic sheeting is easily vandalized, easily torn, and photodegradable.

WHEN BMP IS TO BE INSTALLED:

Geotextiles and plastic covers should be installed immediately after completion of a phase of grading or while the stockpile is in place.

STANDARDS AND SPECIFICATIONS:

Geotextile blankets shall be secured in place with wire staples or sandbags and by keying into tops of slopes and edges to prevent infiltration of surface water under the geotextile. Plastic sheeting shall be keyed in at the top of the slope and firmly held in place with sandbags or other weights placed no more than 10 feet apart. Seams are typically taped or weighted down their entire length. Anchoring the sheeting is crucial to keeping it in place during windy weather.

OPERATION AND MAINTENANCE PROCEDURES:

All geotextile and plastic sheeting shall be inspected on a weekly basis and after storms to check for erosion, undermining, and anchorage failure. Any failures shall be repaired immediately. If washout or breakages occur, the material shall be re-installed after repairing the damage to the slope.

SITE CONDITIONS FOR REMOVAL:

Upon establishment of other temporary stabilizations or after permanent stabilization has occurred.

EC-10 OUTLETS/VELOCITY DISSIPATION DEVICES

These devices are placed at pipe outlets to prevent scour and reduce the velocity and/or energy of storm water flows. These devices protect the receiving area from erosion.



APPROPRIATE APPLICATIONS:

These devices may be used at the following locations: outlets of pipes, drains, culverts, slope drains, diversion ditches, swales, conduits or channels, outlets located at the bottom of mild to steep slopes, discharge outlets that carry continuous flows of water, outlets subject to short, intense flows of water, such as flash floods, points where lined conveyances to unlined conveyances, and at emergency overflows or outlet pipes of a sediment basin.

CONDITIONS FOR EFFECTIVE USE:

Type of Flow: Concentrated flow

WHEN BMP IS TO BE INSTALLED:

Energy dissipation devices should be installed with the construction of the upstream BMP or pipe that creates a concentrated discharge.

STANDARDS AND SPECIFICATIONS:

Install riprap, concrete apron, etc. at selected outlet. Riprap aprons are best suited for temporary use during construction. Carefully place riprap to avoid damaging the filter fabric. Align the apron with the receiving stream and keep straight throughout its length. If a curve is needed to fit site conditions, place it in the upper section of the apron. If the size of the apron riprap is comprised of large rocks, protect the underlying filter fabric with a gravel blanket. Outlets on slopes steeper than 10% need additional protection.

OPERATION AND MAINTENANCE PROCEDURES:

Inspect at least every week and after every storm during construction. Remove sediment and trash accumulation. Inspect apron for displacement of the riprap and/or damage to the underlying fabric. Repair fabric and replace riprap that has washed away. Inspect for scour beneath the riprap and around the outlet. Repair damage to slopes immediately, extend the pad or place larger rock, as needed.

SITE CONDITIONS FOR REMOVAL:

Temporary devices need to be completely removed as soon as the surrounding drainage area has been stabilized, or at the completion of construction.

STANDARD DRAWING: EC-10

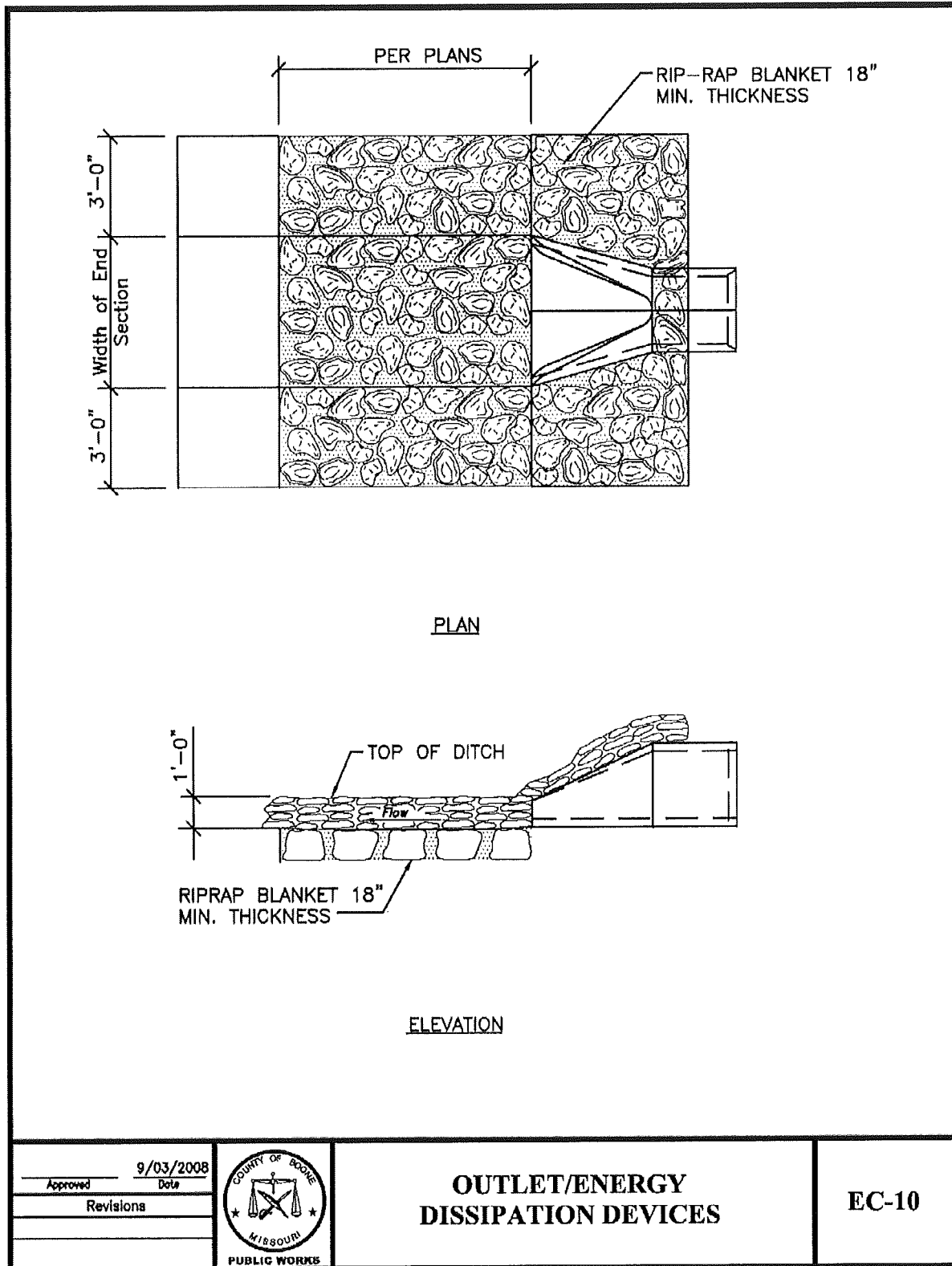



EC-11 TEMPORARY STREAM CROSSING

A temporary stream crossing is a structure placed across a waterway that allows vehicles to cross the waterway during construction, minimizing, reducing, or managing erosion and downstream sedimentation caused by the vehicles. Use of temporary stream crossings is discouraged. Crossings are a direct source of pollution and should be avoided if alternatives are feasible.

APPROPRIATE APPLICATIONS:

Temporary stream crossings are installed at sites: where appropriate permits have been secured (404, 401, etc.), where construction equipment or vehicles need to frequently cross a waterway, when alternate access routes impose significant constraints, and where construction activities will be less than 1 year.

CONDITIONS FOR EFFECTIVE USE:

Design considerations include: current and proposed watershed conditions, average and peak discharge (2 year, 24 hour storm), effect on water surface elevation off-site, velocity, sediment removal, and protection of fish and trees. Criteria for a Low Water Crossing includes: any constant flow less than 3" deep, light traffic, bank height less than 5 feet, and perpendicular to flow or with a slight upstream arc. Criteria for a culvert crossing includes: sized for 2 year, 24 hour storm with 1 foot freeboard and no flooding of offsite areas, pipe parallel to flow, embankment perpendicular to channel or with a slight upstream arc, riprap on exposed faces sized for overtopping during a peak storm period.

WHEN BMP IS TO BE INSTALLED:

The temporary stream crossing should be constructed during dry periods and may require dewatering or temporary diversion of the stream.

STANDARDS AND SPECIFICATIONS:

Procedures are specific to the type of crossing used. Generally, provide a stable means to bypass normal channel flow prior to disturbing channel, stabilize channel bottom, install culvert (if used), grade and compact access ramps and soil embankment, install fabric, stone, and riprap according to design.

OPERATION AND MAINTENANCE PROCEDURES:

Inspect every week and after every storm-checking for: blockage in the channel, debris buildup, erosion of abutments, channel scour, riprap displacement, piping of soil, and structural weakening. Remove sediment and trash accumulation. Repair and stabilize eroded areas-extend riprap if necessary.

SITE CONDITIONS FOR REMOVAL:



Remove as soon as alternative access is available. All foreign materials should be removed from creek. The streambed/banks should be returned to the original contour and stabilized if necessary.

STANDARD DRAWING: EC-11a and EC-11b

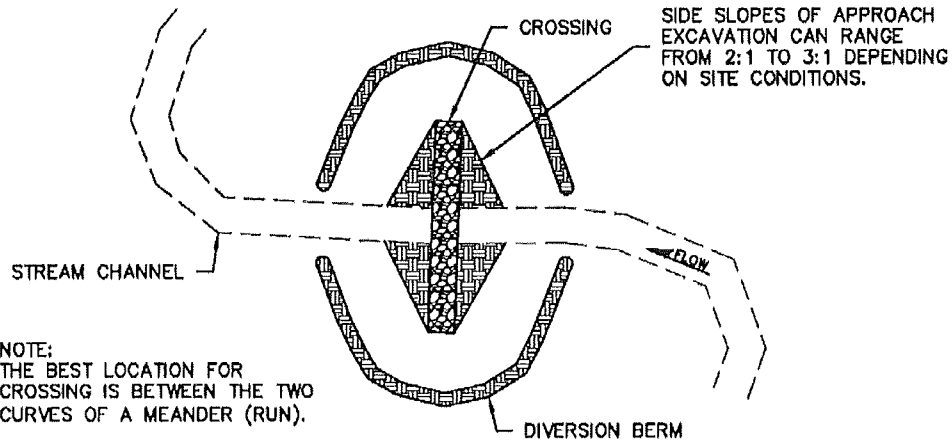

REINFORCED STREAM CROSSING LAYOUT
NOT TO SCALE

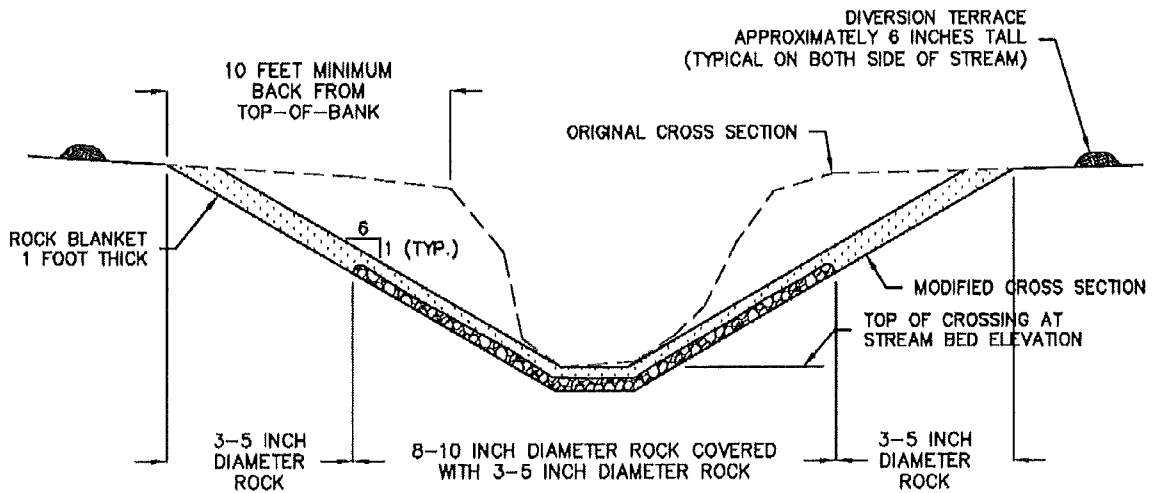

REINFORCED STREAM CROSSING PROFILE
NOT TO SCALE

| | | | |
|--|--|--|----------------------|
| <p>Approved _____ Date <u>9/03/2008</u></p> <p>Revisions _____</p> | | <p>REINFORCED STREAM CROSSING</p> | <p>EC-11A</p> |
|--|--|--|----------------------|



GENERAL NOTES AND SPECIFICATIONS FOR TEMPORARY (REINFORCED) STREAM CROSSINGS:

1. THE STREAM BED FOR 0.5 MILE BELOW THE PROPOSED CROSSING MUST BE VERTICALLY STABLE. THE CHANNEL SHOULD NOT BE DOWNCUTTING (NO HEADCUTS DOWNSTREAM) OR RAPIDLY FILLING WITH SEDIMENT.
2. LOW FLOW WATER DEPTH SHALL BE LESS THAN SIX INCHES.
3. STREAM BANKS IN THE VICINITY (0.25 MILES UPSTREAM AND DOWNSTREAM) MUST BE STABLE.
4. THE CROSSING SHOULD BE LOCATED IN THE STRAIGHT REACH BETWEEN TWO BENDS.
5. APPROACHES SHOULD BE NO STEEPER THAN 6:1.
6. THE APPROACHES AND CROSSING SHOULD BE OVER EXCAVATED ONE FOOT THAN THE DESIRED SURFACE.
7. THE CROSSING AND THE APPROACHES FOR 10 FEET ON EITHER SIDE OF THE CROSSING SHOULD BE BACKFILLED WITH 8-10 INCH DIAMETER ROCK OR QUARRY RUN SHOT-ROCK TO WITHIN THREE TO FIVE INCHES OF THE DESIRED SURFACE. THE LARGE ROCK SHOULD BE COMPACTED INTO THE STREAM BED AND THE APPROACHES.
8. AFTER THE LARGE ROCK IS COMPACTED, THREE TO FIVE INCH DIAMETER ROCK SHOULD BE PLACED IN THE REMAINDER OF THE APPROACHES AND OVER THE LARGE ROCK TO PROVIDE A RELATIVELY SMOOTH SURFACE.
9. FINAL ELEVATION OF THE PORTION OF THE CROSSING SUBMERGED AT LOW FLOW SHALL NOT BE MORE THAN THREE INCHES ABOVE STREAM BED ELEVATION.
10. SIDE SLOPES OF THE APPROACH CAN RANGE FROM 2:1 TO 3:1 DEPENDING ON CONDITIONS AT THE SITE.
11. SIX INCH TALL DIVERSION BERM SHOULD BE BUILT AROUND THE CROSSING TO PREVENT OVERLAND FLOW FROM ERODING THE APPROACHES. THE DIVERSIONS SHOULD OUTLET AT STABLE LOCATIONS.
12. GROUTING (POURING CONCRETE OVER ROCK) IS PROHIBITED.
13. THE CROSSING SHOULD BE INSPECTED AFTER EACH FLOOD. BE ALERT FOR SIGNIFICANT SCOUR DOWNSTREAM OF THE CROSSING. THE SMALL DIAMETER ROCK MAY HAVE TO BE REPLACED OVER TIME. FREQUENT CLEARING OF SEDIMENT AND DEBRIS FROM THE APPROACHES WILL BE NECESSARY.

| | | | | |
|--|---|--|-----------------------------------|---------------|
| | 9/03/2008 <small>Approved Date</small> | | REINFORCED STREAM CROSSING | EC-11B |
| | Revisions | | | |
| | | | | |



RM-1 CHECK DAMS

Check dams reduce scour and channel erosion by reducing flow velocity and encouraging sediment settlement. A check dam is a small device constructed of rock, gravel bags, sandbags, fiber rolls, or other proprietary product placed across a natural or man-made channel or drainage ditch.

APPROPRIATE APPLICATIONS:

Check dams can be placed at intervals along drainage swales or channels. The top of the downstream check dam should be level with the base of the upstream check dam. Check dams can also be used during the establishment of grass linings in drainage ditches or channels or in temporary ditches where the short length of service does not warrant establishment of erosion-resistant linings. Not to be used in streams.

CONDITIONS FOR EFFECTIVE USE:

Type of Flow: Moderate concentrated flow.

WHEN BMP IS TO BE INSTALLED:

Check dams can be installed prior to disturbance of natural vegetation in the contributing drainage area or immediately after construction of a drainage way.

STANDARDS AND SPECIFICATIONS:

Check dams should be placed at a distance and height to allow small pools to form behind them. Install the first check dam approximately 16 feet from the outfall device and at regular intervals based on slope gradient and soil type. For multiple check dam installation, backwater from the downstream check dam should reach the toe of the upstream dam. High flows (typically a 2-year storm or larger) should safely flow over the check dam without an increase in upstream flooding.

OPERATION AND MAINTENANCE PROCEDURES:

Inspect at least every week and after every storm. Remove trash and leaf accumulation. Remove sediment when depth reaches one-half of the check dam height. Repair/restore dam structure, if necessary, to original configuration to protect the banks.

SITE CONDITIONS FOR REMOVAL:

Remove after contributing areas have been adequately stabilized and vegetation is adequately established in drainage way. Regrade and vegetate the area.

STANDARD DRAWING: RM-1

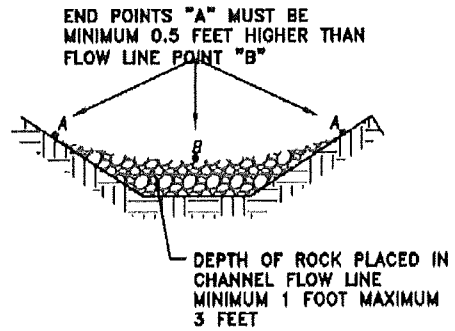
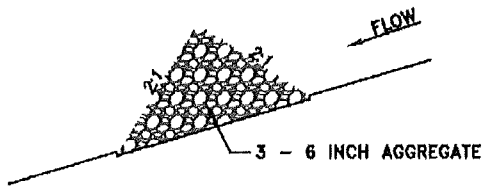

FRONT VIEW

PLACE DOWNSTREAM STRUCTURE SUCH THAT POINT "B" IS APPROXIMATELY LEVEL WITH THE TOE ELEVATION OF THE UPSTREAM STRUCTURE

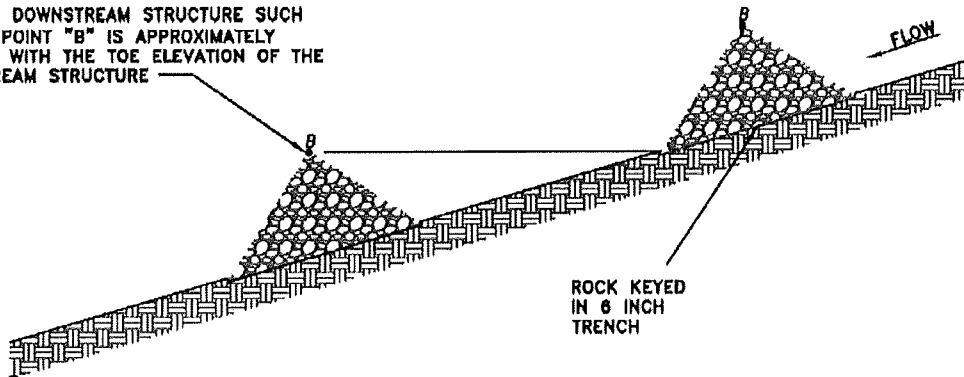

SIDE VIEW

NOTE:

ROCK CHECK DAMS SHALL BE USED ONLY FOR DRAINAGE AREAS LESS THAT 10 ACRES UNLESS APPROVED BY THE ENGINEER.

| | | | |
|------------------------------------|--|--------------------------|--------------------|
| <p>9/03/2008 Approved Date</p> | | <p>CHECK DAMS</p> | <p>RM-1</p> |
| <p>Revisions</p> | | | |
| <p> </p> | | | |



RM-2 EARTH BERMS AND DRAINAGE SWALES

A compacted earth, compost or gravel ridge, excavated channel or a combination of ridge and channel designed to direct runoff away from or around disturbed areas. Diversions built on a level contour are used in combination with temporary slope drains to provide adequate conveyance. Diversions built with positive drainage slopes release runoff into additional BMPs, such as sediment traps or level spreaders.

APPROPRIATE APPLICATIONS:

These features may be used to: convey surface runoff down sloping land, intercept and divert runoff to avoid sheet flow over sloped surfaces, divert and direct runoff towards a stabilized watercourse, drainage pipe or channel, intercept runoff from paved surfaces. Berms, swales, and lined ditches also may be used: below steep grades where runoff begins to concentrate, along roadways and facility improvements subject to flood drainage, at the top of slopes to divert runoff from adjacent or undisturbed slopes and at bottom and mid-slope locations to intercept sheet flow or to convey concentrated flows.

CONDITIONS FOR EFFECTIVE USE:

Type of Flow: Sheet flow and low-volume concentrated flows.

Contributing Area: Contributing slope length-300 feet maximum; 100 feet for slopes greater than 5%.

WHEN BMP IS TO BE INSTALLED:

Berms and/or swales should be installed prior to disturbance of natural vegetation on slopes and at intervals during construction of fill slopes.

STANDARDS AND SPECIFICATIONS:

Care must be applied to correctly size and locate berms, swales, and ditches. Excessively steep, unlined berms and swales are subject to gully erosion. Grade and compact the channel and/or ridge. Provide stabilized outfall areas. Conveyances should be stabilized with vegetation or a protective lining. Other BMPs, such as check dams and erosion control blankets, may be necessary to prevent scour and erosion.

OPERATION AND MAINTENANCE PROCEDURES:

Inspect at least every week and after every storm. Inspect channel linings, embankments, and beds of ditches and berms for erosion and accumulation of debris and sediment. Remove debris and sediment, repair linings and embankments as needed-replace riprap, linings or soil stabilizers as needed.

SITE CONDITIONS FOR REMOVAL:

Temporary diversions should be removed as soon as the surrounding drainage area has been stabilized.

STANDARD DRAWING: RM - 2

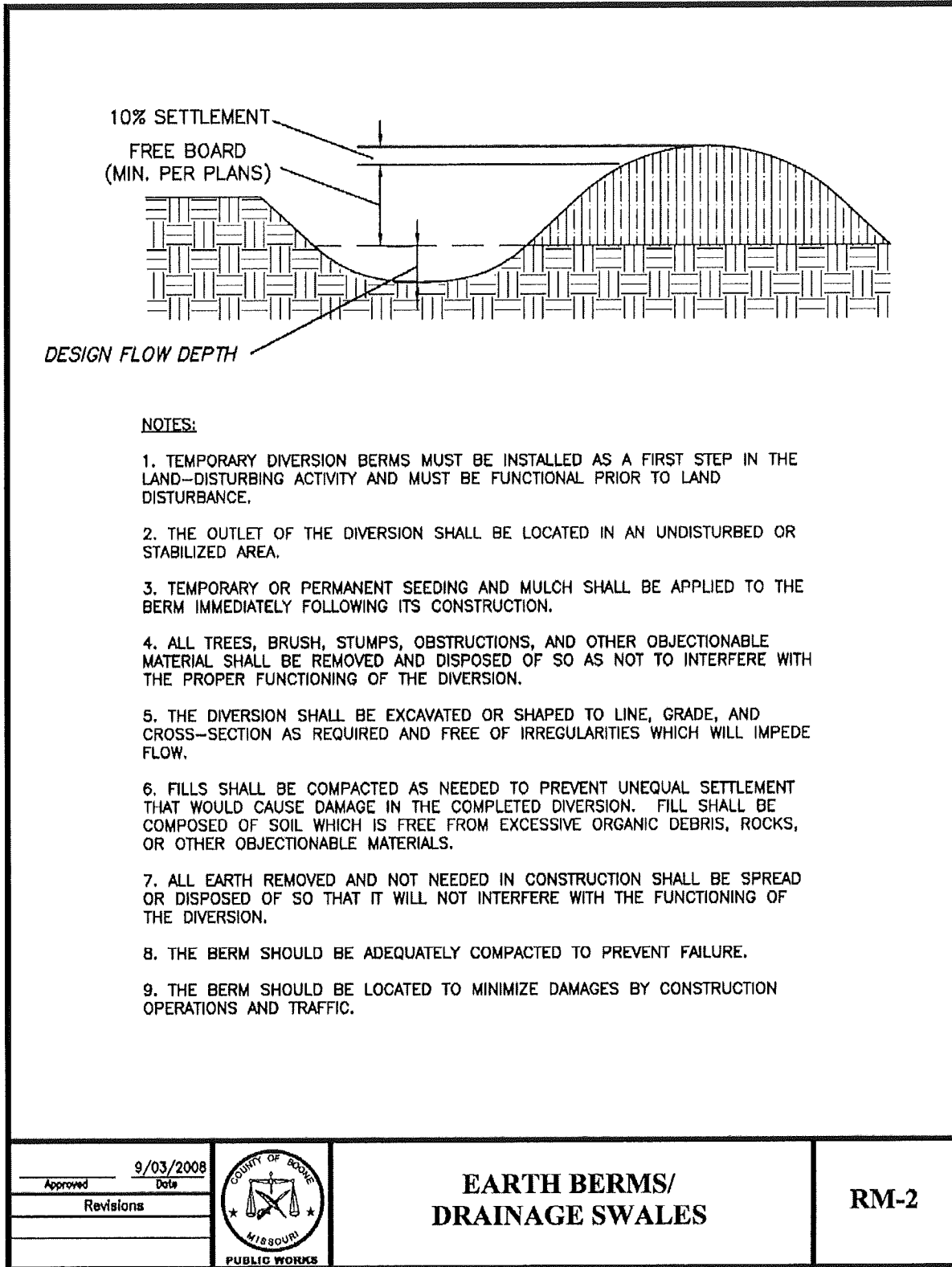

NOTES:

1. TEMPORARY DIVERSION BERMS MUST BE INSTALLED AS A FIRST STEP IN THE LAND-DISTURBING ACTIVITY AND MUST BE FUNCTIONAL PRIOR TO LAND DISTURBANCE.
2. THE OUTLET OF THE DIVERSION SHALL BE LOCATED IN AN UNDISTURBED OR STABILIZED AREA.
3. TEMPORARY OR PERMANENT SEEDING AND MULCH SHALL BE APPLIED TO THE BERM IMMEDIATELY FOLLOWING ITS CONSTRUCTION.
4. ALL TREES, BRUSH, STUMPS, OBSTRUCTIONS, AND OTHER OBJECTIONABLE MATERIAL SHALL BE REMOVED AND DISPOSED OF SO AS NOT TO INTERFERE WITH THE PROPER FUNCTIONING OF THE DIVERSION.
5. THE DIVERSION SHALL BE EXCAVATED OR SHAPED TO LINE, GRADE, AND CROSS-SECTION AS REQUIRED AND FREE OF IRREGULARITIES WHICH WILL IMPEDE FLOW.
6. FILLS SHALL BE COMPACTED AS NEEDED TO PREVENT UNEQUAL SETTLEMENT THAT WOULD CAUSE DAMAGE IN THE COMPLETED DIVERSION. FILL SHALL BE COMPOSED OF SOIL WHICH IS FREE FROM EXCESSIVE ORGANIC DEBRIS, ROCKS, OR OTHER OBJECTIONABLE MATERIALS.
7. ALL EARTH REMOVED AND NOT NEEDED IN CONSTRUCTION SHALL BE SPREAD OR DISPOSED OF SO THAT IT WILL NOT INTERFERE WITH THE FUNCTIONING OF THE DIVERSION.
8. THE BERM SHOULD BE ADEQUATELY COMPACTED TO PREVENT FAILURE.
9. THE BERM SHOULD BE LOCATED TO MINIMIZE DAMAGES BY CONSTRUCTION OPERATIONS AND TRAFFIC.

| | | | | | | | | | | | | | |
|--|-----------|------|----------|--|-----------|--|--|--|--|--|--|--|--------------------|
| <table border="1"> <tr> <td style="width: 50%; text-align: center;">9/03/2008</td> <td style="width: 50%; text-align: center;">Date</td> </tr> <tr> <td colspan="2" style="text-align: center;">Approved</td> </tr> <tr> <td colspan="2" style="text-align: center;">Revisions</td> </tr> <tr> <td colspan="2" style="text-align: center;"> </td> </tr> <tr> <td colspan="2" style="text-align: center;"> </td> </tr> </table> | 9/03/2008 | Date | Approved | | Revisions | | | | | | | <p>EARTH BERMS/ DRAINAGE SWALES</p> | <p>RM-2</p> |
| 9/03/2008 | Date | | | | | | | | | | | | |
| Approved | | | | | | | | | | | | | |
| Revisions | | | | | | | | | | | | | |
| | | | | | | | | | | | | | |
| | | | | | | | | | | | | | |



RM-3 TERRACING

Terracing involves defined swales constructed at regular intervals along the face of a slope designed to reduce erosion by capturing surface runoff and directing it to an adequate, stable outlet.

APPROPRIATE APPLICATIONS:

Typically installed on long steep slopes on which erosion is a concern. Terraces should not be constructed in sandy or rocky soil.

CONDITIONS FOR EFFECTIVE USE:

Type of Flow: Sheet flow.

Slope Characteristics: Maximum of 3:1 slope.

Contributing Slope Length: Maximum of 30 feet for slopes steeper than 4:1; maximum for 50 feet for 4:1 and flatter.

WHEN BMP IS TO BE INSTALLED:

Terracing should be installed as fill is constructed. On existing slopes, terraces should be graded prior to removal of vegetation.

STANDARDS AND SPECIFICATIONS:

Grade terraces as required by the design. Construct the stable outfall as designed. Vegetate the slope and terraces immediately after BMP installation.

OPERATION AND MAINTENANCE PROCEDURES:

Inspect at least every week and after every storm during construction. Remove sediment accumulations along terraces. Repair settled and eroded areas. Remove sediment and stabilize eroded areas at outlet. Revegetate as needed

STANDARD DRAWING: RM - 3

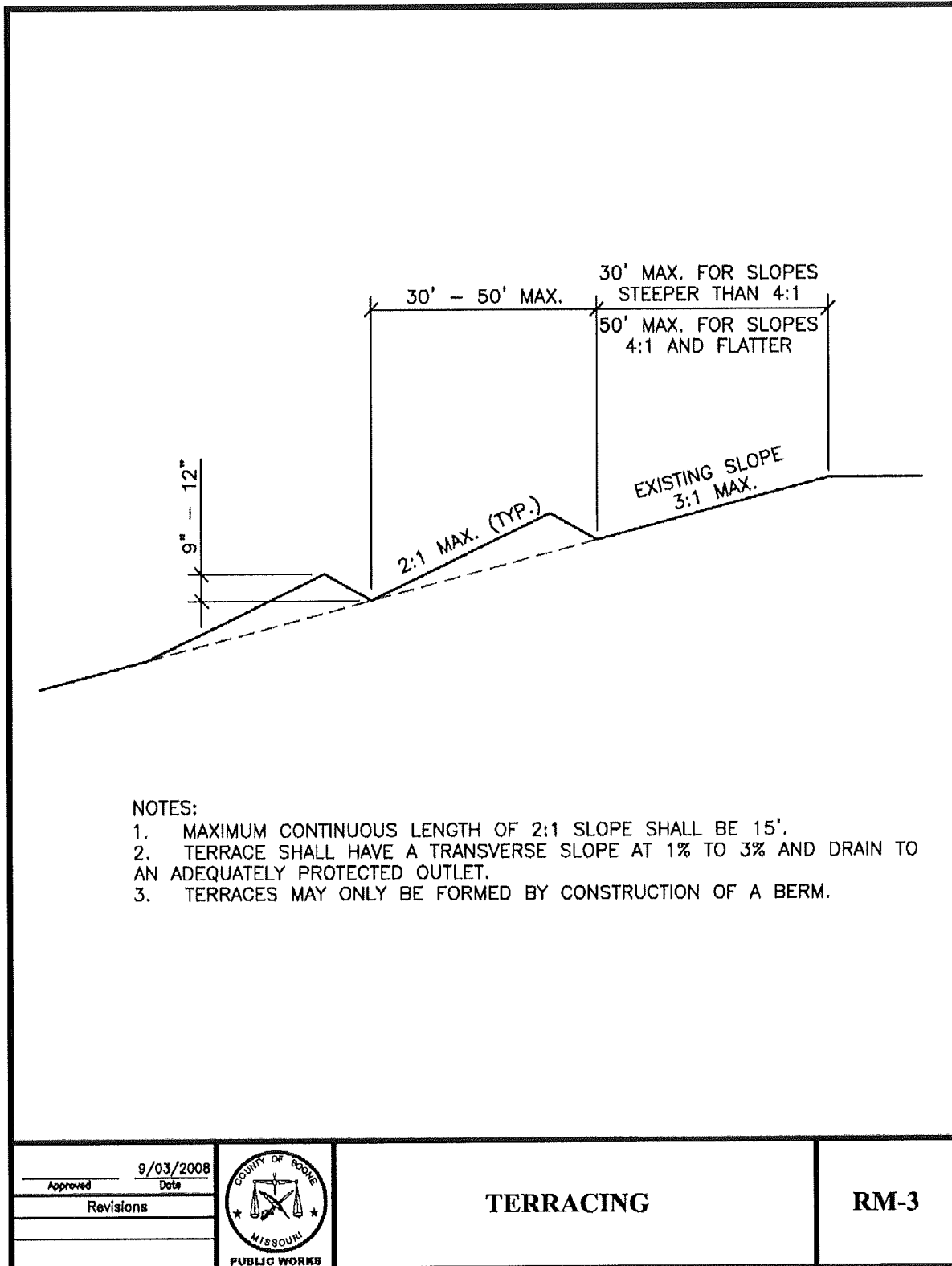



RM-4 SLOPE DRAINS

A slope drain is a flexible or rigid pipe which extends from the top to the bottom of a cut or fill slope. These structures are designed to protect exposed slopes from upstream runoff and can be used with other BMPs to intercept and direct surface flow away from disturbed slope areas. Slope drains typically extend beyond the toe of the slope to a stable area or outlet.

APPROPRIATE APPLICATIONS:

Slope drains may be used on construction sites where slopes may be eroded by surface runoff.

CONDITIONS FOR EFFECTIVE USE:

Type of Flow: Sheet flow and concentrated flow. Contributing Area: Maximum of 5 acres per slope drain; pipe sized for 15 year, 20 minute storm.

WHEN BMP IS TO BE INSTALLED:

Slope drains should be installed concurrently with diversion devices as soon as cut and fill operations have occurred.

STANDARDS AND SPECIFICATIONS:

Slope drains must be installed and maintained properly because failure will usually result in severe erosion of the slope. Other points of concern are failure from overtopping due to inadequate pipe inlet capacity or blockage, and lack of maintenance of the upstream diversion device capacity. Generally install slope drain down the slope-perpendicular to slope contours, extending beyond toe of slope. Install flared end or t-section at pipe inlet. Section should be well entrenched and stable so water can enter freely. Place compacted fill over and around pipe in the area of diversion device. Ensure that all pipe connections are secure. Securely anchor the exposed section of the drain with stakes. Install flared end section at pipe outlet-discharge into a sediment trap or other stabilized outlet. Protect area around inlet with filter fabric. Protect outlet with riprap or other energy dissipation device.

OPERATION AND MAINTENANCE PROCEDURES:

Inspect at least every week and after every storm during construction. Remove sediment and trash accumulation at inlet. Repair settlement, cracking, or piping holes. Repair leaks or inadequate anchoring along pipe. Remove sediment and stabilize eroded areas at outlet-extend if necessary.

SITE CONDITIONS FOR REMOVAL:

Remove concurrently with upstream diversion device after slope has been stabilized. Stabilize the exposed areas where the slope drain and diversion device were removed.

STANDARD DRAWING: RM - 4

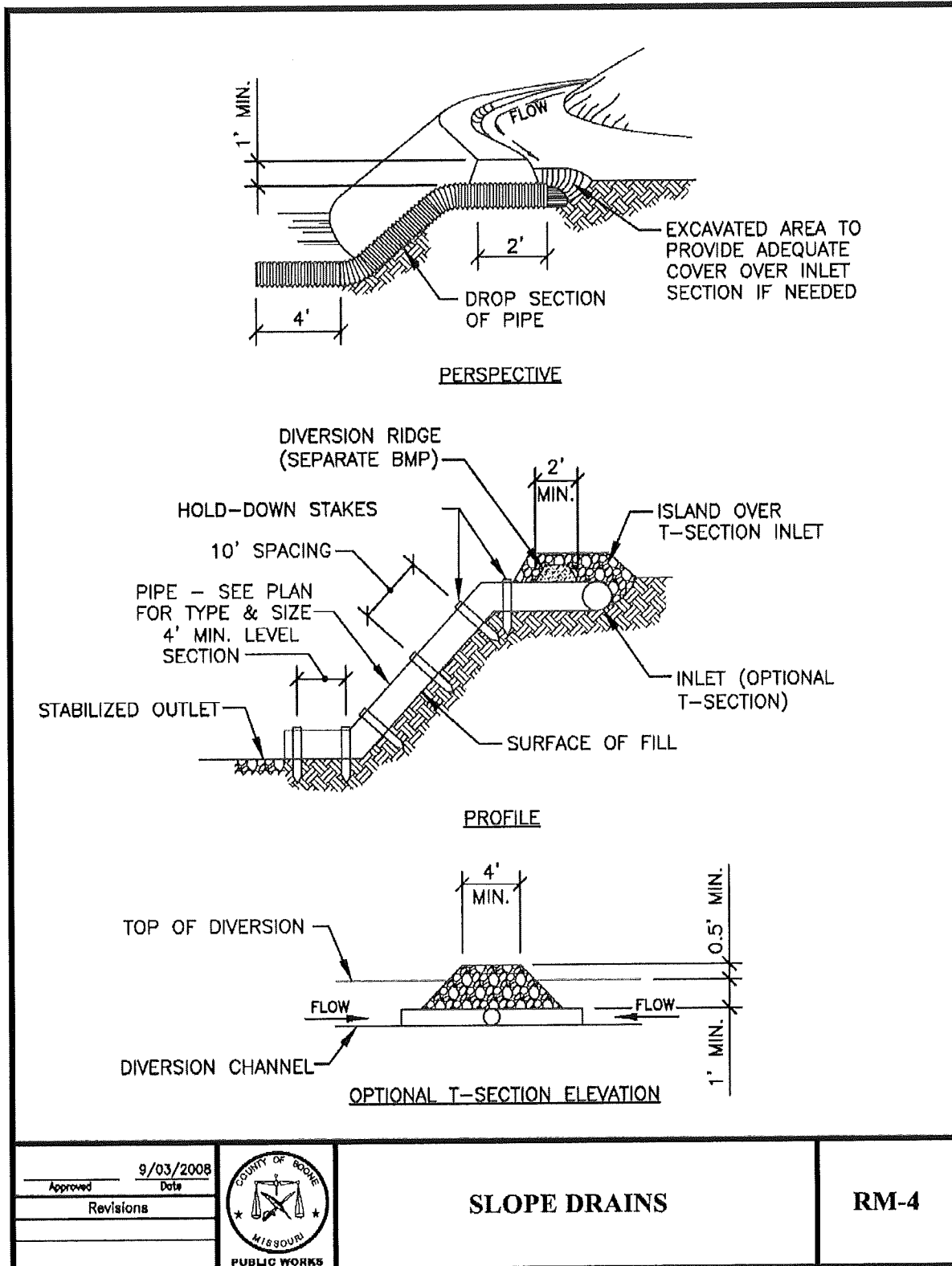

| | |
|-----------|-----------|
| Approved | 9/03/2008 |
| | Date |
| Revisions | |
| | |
| | |



SLOPE DRAINS

RM-4



RM-5 SOIL ROUGHENING

Soil roughening is a temporary erosion control practice often used in conjunction with grading. Soil roughening involves increasing the relief of a bare soil surface with horizontal grooves by either stair-stepping (running parallel to the contour of the land) or using construction equipment to track the surface. Slopes that are not fine graded and left in a roughened condition can reduce erosion by reducing runoff velocity, increasing infiltration, trapping sediment and preparing the soil for seeding and planting by giving seed an opportunity to take root and grow.

APPROPRIATE APPLICATIONS:

Soil roughening is appropriate for all slopes, but works especially well on slopes greater than 3:1, on piles of excavated soil, and in areas with highly erodible soils. This technique is especially appropriate for soils that are frequently disturbed, because roughening is relatively easy.

CONDITIONS FOR EFFECTIVE USE:

Type of Flow: Sheet flow.

Contributing Area: Unlimited on slopes <10%, slopes >10% require additional BMPs

WHEN BMP IS TO BE INSTALLED:

Soil roughening should be done immediately after rough grading; prior to seeding or mulching.

STANDARDS AND SPECIFICATIONS:

Methods for roughening soil differ depending on the type of slope and the available equipment. These methods include stair-step grading, grooving, and tracking. When choosing a method, consider factors such as slope steepness, mowing requirements, whether the slope is formed by cutting or filling, and available equipment. Soil roughening is not appropriate for rocky slopes. Tracked machinery can excessively compact the soil, therefore lightweight machinery should be used.

OPERATION AND MAINTENANCE PROCEDURES:

Inspect at least every week and immediately after every storm. Rework the slope and regroove after sediment buildup is deeper than ½ the groove depth, or if rills have formed across the roughened surface.

SITE CONDITIONS FOR REMOVAL:

The slope should be reworked to the design grades prior to final stabilization.



RM-6 FIBER ROLLS/WATTLES

Fiber rolls (also called fiber logs or straw wattles) are tube-shaped erosion-control devices filled with straw, flax, rice, coconut fiber material, or composted material. Each roll is wrapped with UV-degradable polypropylene netting for longevity or with 100 percent biodegradable materials like burlap, jute, or coir. These devices reduce erosion on long or steep slopes by breaking up the slope length.

APPROPRIATE APPLICATIONS:

Fiber rolls can be used in areas of low shear stress such as; along the toe, top, face, and at-grade breaks of exposed and erodible slopes to shorten slope length and spread runoff as sheet flow, at the end of a downward slope where it transitions to a steeper slope, along the perimeter of a project or stockpile, as check dams in unlined ditches, and downslope of exposed soil areas.

CONDITIONS FOR EFFECTIVE USE:

Type of Flow: Sheet flow and concentrated flow.

WHEN BMP IS TO BE INSTALLED:

Wattles should be installed immediately after rough grading; prior to seeding or mulching.

STANDARDS AND SPECIFICATIONS:

On slopes, install fiber rolls along the contour with a slight downward angle at the end of each row to prevent ponding at the midsection. Turn the ends of each fiber roll upslope to prevent runoff from flowing around the roll. Determine the vertical spacing for slope installations on the basis of the slope gradient and soil type. A good rule of thumb is: 1:1 slopes=10 feet apart, 2:1 slopes=20 feet apart, 3:1 slopes=30 feet apart, and 4:1 slopes=40 feet apart. Stake fiber rolls securely into the ground and orient them perpendicular to the slope. Fiber rolls can also be used at projects with minimal slopes. Typically, the rolls are installed along sidewalks, on the bare lot side, to keep sediment from washing onto sidewalks and streets and into gutters and storm drains.

OPERATION AND MAINTENANCE PROCEDURES:

Inspect at least every week and after every storm. Remove sediment accumulation when it reaches $\frac{1}{2}$ the height of the roll/wattle. Repair or replace split, torn, unraveled, or slumping fiber rolls.

SITE CONDITIONS FOR REMOVAL:

Fiber rolls are typically left in place on slopes. If they are removed after stabilization has been achieved, collect and dispose of the accumulated sediment.

STANDARD DRAWING: RM-6

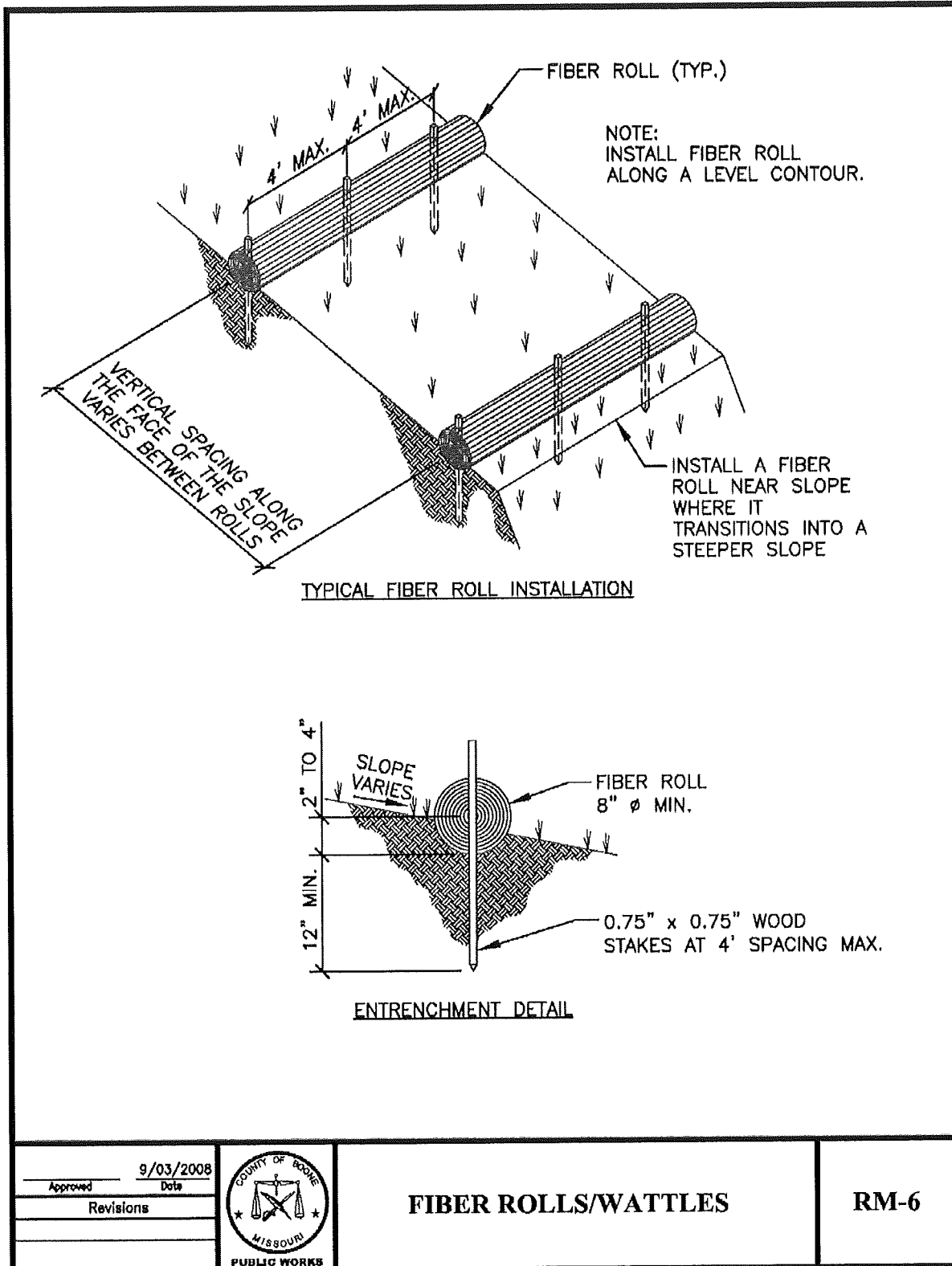



SC-1 VEGETATED FILTER STRIP

Vegetated filter strips or buffers are areas of natural or established vegetation maintained to protect the water quality of neighboring areas. Buffer zones slow stormwater runoff, provide an area where runoff can permeate the soil, contribute to ground water recharge, and filter sediment. Slowing runoff also helps to prevent soil erosion and streambank collapse.

APPROPRIATE APPLICATIONS:

Vegetated buffers can be used in any area able to support vegetation. They are most effective and beneficial on floodplains, near wetlands, along streambanks, and on unstable slopes. Filter strips can be used adjacent to low or medium density residential areas on gently sloping ground.

CONDITIONS FOR EFFECTIVE USE:

Type of Flow: Overland sheet flow only-cannot treat high velocity flows.

WHEN BMP IS TO BE INSTALLED:

Filter strips can be established immediately after rough grading to trap sediment during construction and/or immediately after final grading as a permanent measure to control surface runoff.

STANDARDS AND SPECIFICATIONS:

Determine buffer widths after carefully considering slope, vegetation, soils, depth to impermeable layers, runoff sediment characteristics, type and amount of pollutants, and annual rainfall. Make sure buffer widths increase as slope increases. In areas where flows are more concentrated and fast, combine buffer zones with other practices such as level spreaders, infiltration areas, or diversions to prevent erosion and rilling. Fence off any undisturbed vegetated strips to be preserved. No activity, including parking/storing vehicles or equipment, shall be permitted in the vegetated/woody strip. If a grass filter strip is constructed, it must be completed and vegetated before construction in a contributing area is started.

OPERATION AND MAINTENANCE PROCEDURES:

Inspect at least every week and after every storm. Remove sediment accumulation once it reaches 6" in depth. Fill and compact eroded areas and reseed, mulch and fertilize or establish other vegetation in the affected areas. After improvements are complete, regrade and reseed the top edge of the filter strip to remove sediment trapped during construction and prolong the effective use of the filter strip.



SC-2 SILT FENCE

A silt fence is a length of filter fabric stretched between anchoring posts spaced at regular intervals along the site at low/downslope areas. The filter fabric should be entrenched in the ground at least 6". When installed correctly and inspected frequently, silt fences encourages the ponding of runoff and can be an effective barrier to sediment leaving the site.

APPROPRIATE APPLICATIONS:

Installed along slopes, at base of slopes, and around the perimeter of a site as a final barrier to sediment being carried off site. Silt fence should not be used in areas of concentrated flow or as check dams.

CONDITIONS FOR EFFECTIVE USE:

Type of Flow: Sheet flow only

Contributing Area: Drainage area should not exceed 0.25 acres per 100-foot fence length.

Slope Length: The slope length above the fence should not exceed 100 feet.

WHEN BMP IS TO BE INSTALLED:

Silt fence should be installed prior to disturbance of natural vegetation and at intervals during construction of fill slopes.

STANDARDS AND SPECIFICATIONS:

If a standard-strength fabric is used, it can be reinforced with wire mesh behind the filter fabric. This increases the effective life of the fence. The maximum life expectancy for synthetic fabric silt fences is about 6 months, depending on the amount of rainfall and runoff. The fence should be designed to withstand the runoff from a 10-year peak storm event. Generally, drive posts for fence line, dig trench to required dimensions in front of posts for fabric burial, attach wire mesh to posts (if necessary), attach fabric to posts-allowing required length below ground level to run fabric along bottom of trench, and backfill and compact soil in trench to protect and anchor fabric. Alternate (and actually preferred) construction procedures include installing the fence by slicing it into the ground with specialized equipment.

OPERATION AND MAINTENANCE PROCEDURES:

Inspect at least every week and after every storm. Monitor and remove sediment buildup that is deeper than ½ the fence height. Replace torn/clogged fabric; repair loose fabric. Repair unstable or broken posts. Stabilize any areas susceptible to undermining. Add additional fencing if necessary to provide adequate protection.

SITE CONDITIONS FOR REMOVAL:

After permanent vegetation of slope is established, remove fence, regrade trench area and vegetate.



STANDARD DRAWING: SC-2a and SC-2b

1. EXCAVATE A 6"x4" TRENCH

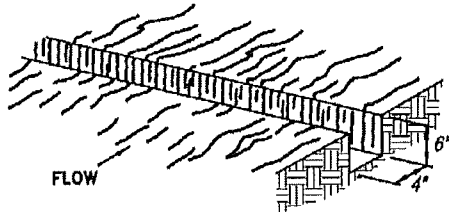

2. SET THE STAKES ALONG THE DOWN SLOPE SIDE OF THE TRENCH.

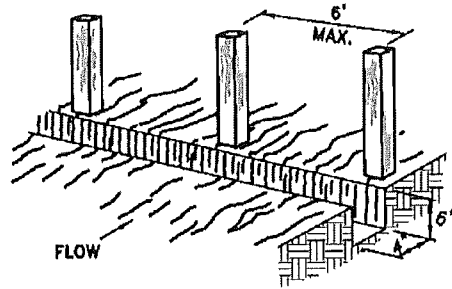

3. STAPLE GEOTEXTILE MATERIAL TO STAKES AND EXTEND IT INTO AND AROUND THE BOTTOM OF THE TRENCH.

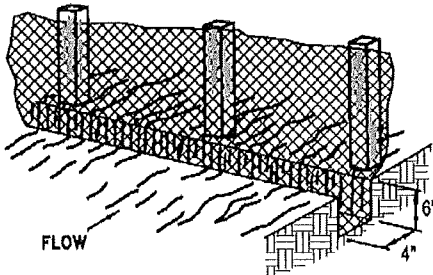

4. BACK FILL AND COMPACT THE EXCAVATED SOIL OVER THE GEOTEXTILE IN THE TRENCH.

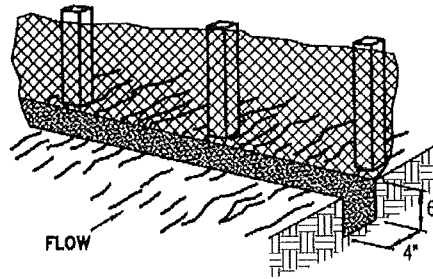

**SHEET FLOW INSTALLATION
(PERSPECTIVE VIEW)
NOT TO SCALE**

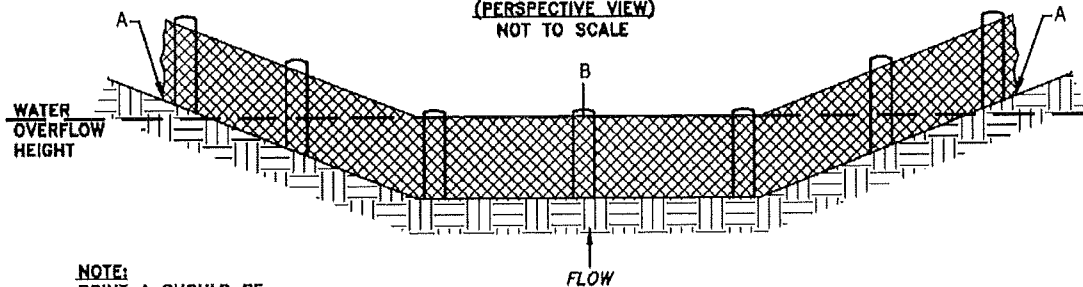

NOTE:
POINT A SHOULD BE
HIGHER THAN POINT B.

**DRAINAGE WAY INSTALLATION
(FRONT ELEVATION)
NOT TO SCALE**

| | | | |
|---|--|--------------------------|---------------------|
| <p>Approved _____ Date <u>9/03/2008</u></p> | | <p>SILT FENCE</p> | <p>SC-2A</p> |
| <p>Revisions _____</p> | | | |
| <p>_____</p> | | | |



SILT FENCE NOTES:

A) INSTALLATION

1. THE HEIGHT OF SILT FENCE SHALL BE A MINIMUM OF 16 INCHES ABOVE THE ORIGINAL GROUND SURFACE AND SHALL NOT EXCEED 34 INCHES ABOVE THE GROUND SURFACE.
2. THE FABRIC SHALL BE PURCHASED IN A CONTINUOUS ROLL CUT TO LENGTH OF THE BARRIER TO AVOID THE USE OF JOINTS. WHEN JOINTS ARE UNAVOIDABLE, FILTER CLOTH SHALL BE SECURELY SPLICED TOGETHER ONLY AT SUPPORT POSTS, WITH A MAX 6 INCH OVERLAP.
3. DIG A TRENCH AT LEAST 6 INCHES DEEP AND 4 INCHES WIDE ALONG THE TRENCH ALIGNMENT.
4. DRIVE POSTS AT LEAST 24 INCHES INTO THE GROUND ON THE DOWNSLOPE SIDE OF THE TRENCH. SPACE POSTS A MAXIMUM OF 6 FEET APART.
5. THE SEDIMENT FABRIC SHALL BE FASTENED SECURELY TO THE UPSLOPE SIDE OF THE POSTS USING A MINIMUM OF ONE INCH LONG, HEAVY-DUTY WIRE STAPLES OR TIE-WIRES, AND EIGHT INCHES OF THE FABRIC SHALL BE EXTENDED INTO THE TRENCH. THE FABRIC SHALL NOT BE STAPLED TO EXISTING TREES.
6. PLACE THE BOTTOM 1 FOOT OF FABRIC IN THE MINIMUM-OF-6-INCH DEEP TRENCH, LAPPING TOWARD THE UPSLOPE SIDE. BACK FILL WITH COMPACTED EARTH OR GRAVEL.
7. IF A SILT FENCE IS TO BE CONSTRUCTED ACROSS A DITCH LINE OR SWALE, IT MUST BE OF SUFFICIENT LENGTH TO ELIMINATE ENDFLOW, AND THE PLAN CONFIGURATION SHALL RESEMBLE AN ARC OR HORSESHOE, PLACED ON A CONTOUR, WITH THE ENDS ORIENTED UPSLOPE. EXTRA-STRENGTH SEDIMENT FABRIC SHALL BE USED WITH A MAXIMUM 3-FOOT SPACING OF POSTS.
8. TO REDUCE MAINTENANCE, EXCAVATE A SHALLOW SEDIMENT STORAGE AREA IN THE UPSLOPE SIDE OF THE FENCE. PROVIDE GOOD ACCESS IN AREA OF HEAVY SEDIMENTATION FOR CLEAN OUT AND MAINTENANCE.
9. SILT FENCES SHALL BE REMOVED WHEN THEY HAVE SERVED THEIR USEFUL PURPOSE, BUT NOT BEFORE THE UPSLOPE AREA HAS BEEN PERMANENTLY STABILIZED.
10. INSTALLATION WITH SLICING METHOD IS PREFERRED.

B) TROUBLESHOOTING:

1. DETERMINE THE EXACT LOCATION OF UNDERGROUND UTILITIES, BEFORE FENCE INSTALLATION SO UTILITIES ARE NOT DISTURBED.
2. GRADE ALIGNMENT OF FENCE NEEDED TO PROVIDE A BROAD, NEARLY LEVEL AREA UPSTREAM OF FENCE TO ALLOW SEDIMENT COLLECTION AREA.

C) INSPECTION MAINTENANCE:

1. INSPECT SILT FENCES AT LEAST ONCE A WEEK AND AFTER EACH 1/2" OF RAINFALL. MAKE ANY REQUIRED REPAIRS IMMEDIATELY.
2. SHOULD THE FABRIC OF A SEDIMENT FENCE COLLAPSE, TEAR, DECOMPOSE, OR BECOME INEFFECTIVE, REPLACE IT PROMPTLY.
3. REMOVE SEDIMENT DEPOSITS AS NECESSARY TO PROVIDE ADEQUATE STORAGE VOLUME FOR THE NEXT RAIN AND TO REDUCE PRESSURE ON THE FENCE, AVOID DAMAGING OR UNDERMINING THE FENCE DURING CLEANOUT. SEDIMENT ACCUMULATION SHOULD NOT EXCEED 1/2 THE HEIGHT OF THE FENCE.
4. REMOVE ALL FENCING MATERIALS AND UNSTABLE SEDIMENT DEPOSITS, AND BRING THE AREA TO GRADE AND STABILIZE IT AFTER THE CONTRIBUTING DRAINAGE AREA HAS BEEN PROPERLY AND COMPLETELY STABILIZED.

| | | | |
|---|---|--------------------------------|---------------------|
| <p>9/03/2008 Approved Date</p> <p>Revisions</p> |  | <p>SILT FENCE NOTES</p> | <p>SC-2B</p> |
|---|---|--------------------------------|---------------------|



SC-3 STRAW BALE DIKE

A straw bale dike consists of a series of straw (or hay) bales butted firmly end to end and anchored in place with stakes placed along the low/downslope areas of a site. The straw bales should be entrenched in the ground. When installed correctly and inspected frequently, straw bale dikes encourage the ponding of runoff and can be an effective barrier to prevent sediment from leaving the site in stormwater runoff.

APPROPRIATE APPLICATIONS:

Installed along slopes, at base of slopes, and around the perimeter of a site as a final barrier to sediment being carried off site. Straw bale dikes should not be used in areas of significant concentrated flow as check dams.

CONDITIONS FOR EFFECTIVE USE:

Type of Flow: Sheet flow and minimal concentrated flow.

Contributing Area: Drainage area should not exceed 0.25 acres per 100-foot fence length. For minor swales where the dike will serve as a ditch check, the drainage area shall not exceed 2 acres.

Slope Length: The slope length above the fence should not exceed 100 feet. Reduce this as the area above the dike steepens.

WHEN BMP IS TO BE INSTALLED:

Straw bale dikes should be installed prior to disturbance of natural vegetation and at intervals during construction of fill slopes.

STANDARDS AND SPECIFICATIONS:

The maximum life expectancy for straw bale dikes is about 3 months, depending on the amount of rainfall and runoff. The dike should be designed to withstand the runoff from a 10-year peak storm event. The dike should be installed on level ground at least 10 feet from the toe of the slope. Excavate a trench at least 4" deep and a bale width wide and long enough that the end bales are upslope of the sediment pool. Anchor bales by driving two 36" long 2"x2" hardwood stakes through each bale until nearly flush with the top. Drive the first stake toward the previously laid bale to force the bales together. Wedge loose straw into any gaps between the bales. Backfill and compact the excavated soil against the bales to ground level on the downslope side and to 4" above ground level on the upslope side.

OPERATION AND MAINTENANCE PROCEDURES:

Inspect at least every week and after every storm. Remove sediment buildup that is deeper than ½ the dike height. Replace deteriorated or damaged bales. Repair unstable or broken stakes.



Stabilize any areas susceptible to undermining. Add additional bales if necessary to provide adequate protection.

SITE CONDITIONS FOR REMOVAL:

After permanent vegetation of slope is established, remove the dike, regrade trench area and vegetate.

STANDARD DRAWING: SC-3

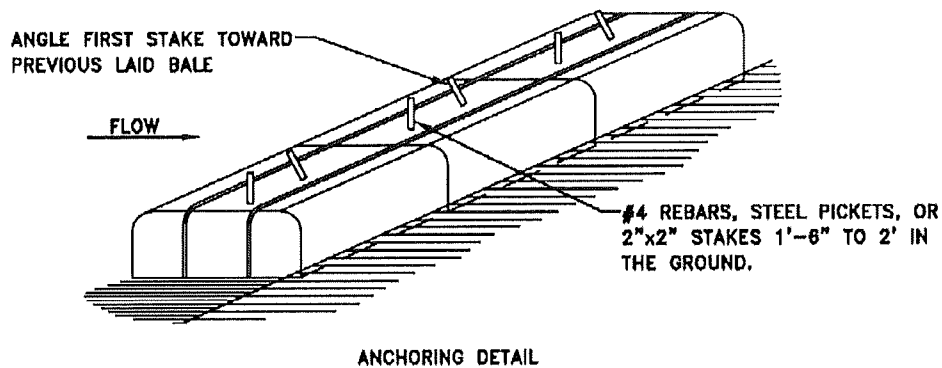
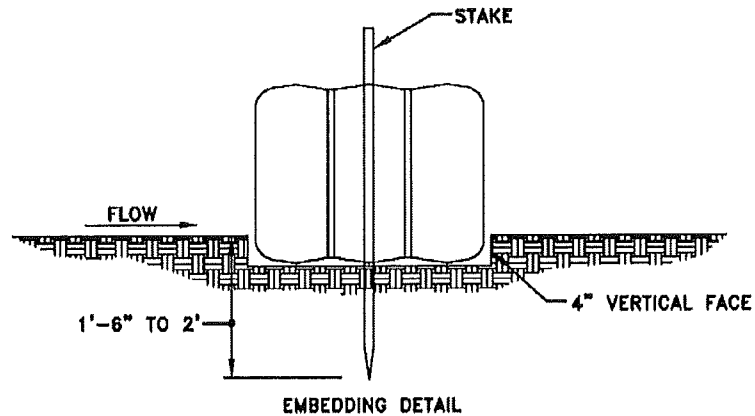

1. BALES SHALL BE PLACED IN A ROW WITH ENDS TIGHTLY ABUTTING THE ADJACENT BALES.
2. EACH BALE SHALL BE EMBEDDED IN THE SOIL A MINIMUM OF 4".
3. BALES SHALL BE SECURELY ANCHORED IN PLACE BY STAKES OR RE-BARS DRIVEN THROUGH THE BALES. THE FIRST STAKE IN EACH BALE SHALL BE ANGLED TOWARD PREVIOUSLY LAID BALE TO FORCE BALES TOGETHER.
4. INSPECTION SHALL BE AT LEAST ONCE A WEEK AND AFTER EACH 1/2" RAIN. REPAIR OR REPLACEMENT SHALL BE MADE PROMPTLY.
5. BALES SHALL BE REMOVED BY THE OWNER WHEN THEY HAVE SERVED THEIR USEFULNESS SO AS NOT TO BLOCK OR IMPEDE STORM FLOW OR DRAINAGE.

| | | | | |
|--|----------------------------|--|------------------------|-------------|
| | 9/03/2008 Approved Date | | STRAW BALE DIKE | SC-3 |
| | Revisions | | | |
| | | | | |



SC-4 COMPOST FILTER SOCKS

A compost filter sock is a type of contained compost filter berm. It is a mesh tube filled with composted material that is placed perpendicular to sheet-flow runoff to control erosion and retain sediment in disturbed areas.

APPROPRIATE APPLICATIONS:

Compost filter socks are generally placed along the perimeter of a site, or at intervals along a slope, to capture and treat stormwater that runs off as sheet flow. Filter socks can also be used on pavement as inlet protection for storm drains and as small check dams to slow water flow in small ditches. Filter socks used for erosion control are usually 12 inches in diameter, although 8 inch, 18 inch, and 24 inch– diameter socks are used in some applications.

CONDITIONS FOR EFFECTIVE USE:

Type of Flow: Sheet flow and small concentrated flow

Contributing Area: Drainage area should not exceed 0.25 acres per 100-foot fence length.

Slope Length: The slope length above the fence should not exceed 100 feet.

WHEN BMP IS TO BE INSTALLED:

Filter socks can be used prior to disturbance of natural vegetation and at intervals during construction of fill slopes.

STANDARDS AND SPECIFICATIONS:

The diameter of the filter sock will vary depending upon the steepness and length of the slope. In areas of concentrated flow, filter socks are sometimes placed in an inverted V going up the slope, to reduce the velocity of water running down the slope. The project engineer may also consider placing filter socks at the top and base of the slope or placing a series of filter socks every 15 to 25 feet along the vertical profile of the slope. Generally, the filter sock is filled, put in place, and anchored using stakes, so no trenching is required. During installation, the ends of the sock should be directed upslope

OPERATION AND MAINTENANCE PROCEDURES:

Inspect at least every week and after every storm. Remove sediment buildup that is deeper than $\frac{1}{2}$ the filter sock height. Repair unstable or broken posts. Stabilize any areas susceptible to undermining. Add additional socks if necessary to provide adequate protection.

SITE CONDITIONS FOR REMOVAL:

Remove the sock after permanent vegetation of slope is established. Regrade trench area and vegetate.



SC-5 COMPOST FILTER BERMS

A compost filter berm is a dike of compost or a compost product that is placed perpendicular to sheet flow runoff to control erosion in disturbed areas and retain sediment. It can be used in place of a traditional control tool such as a silt fence or compost filter socks.

APPROPRIATE APPLICATIONS:

Vegetated compost filter berms are generally placed along the perimeter of a site, or at intervals along a slope. A filter berm also can be used as a check dam in small drainage ditches.

CONDITIONS FOR EFFECTIVE USE:

Type of Flow: Sheet flow and small concentrated flow.

Contributing Area: Drainage area should not exceed 0.25 acres per 100-foot fence length.

WHEN BMP IS TO BE INSTALLED:

Install the compost berm prior to disturbance of natural vegetation and at intervals during construction of fill slopes.

STANDARDS AND SPECIFICATIONS:

The compost filter berm dimensions should be modified based on site-specific conditions, such as soil characteristics, existing vegetation, site slope, and climate, as well as project-specific requirements. Generally the berms are trapezoidal in cross section with the base twice the height of the berm. The compost should be uniformly applied to the soil surface, compacted, and shaped to into a trapezoid. Compost filter berms can be installed on frozen or rocky ground. The filter berm may be vegetated by hand, by incorporating seed into the compost prior to installation, or by hydraulic seeding following berm construction.

OPERATION AND MAINTENANCE PROCEDURES:

Inspect at least every week and after every storm. Remove sediment buildup deeper than ½ the filter berm. Any areas that have been washed away should be replaced. If the berm has experienced significant washout, the filter berm alone may not be the appropriate BMP for the area or the size of the berm may need to be increased.

SITE CONDITIONS FOR REMOVAL:

Vegetated filter berms are normally left in place and provide long-term filtration of stormwater as a post-construction best management practice (BMP). If temporary, break down the berm once construction is complete and spread the compost around the site as a soil amendment or mulch.



SC-6 SEDIMENT BASIN

A temporary settling basin designed to slowly release runoff, detaining it long enough to allow most of the sediment to settle out. Basins should be used in conjunction with additional BMPs, such as temporary seeding, to reduce the total amount of sediment washing into the structure. Sediment basins may also be designed to be converted from a temporary basin to a permanent storm water detention basin after construction has ended.

APPROPRIATE APPLICATIONS:

Should be located as close to the sediment source as possible. A sediment basin should not be used in areas of continuously running water (live streams) nor areas where failure of the embankment will result in loss of life, damage to homes or structures, or prevent the use of roadways or utilities.

CONDITIONS FOR EFFECTIVE USE:

Type of Flow: Sheet flow and concentrated flow.

Basin Volume: Volume of 10 year, 20 minute storm plus silt load of 1800 cf/acre below riser top.

WHEN BMP IS TO BE INSTALLED:

Sediment basins should be placed prior to the disturbance of natural vegetation.

STANDARDS AND SPECIFICATIONS:

For permanent structures, a qualified professional engineer experienced in designing dams should complete the basin design. Excavate basin to length, width, depth and slopes specified on plans. Place and compact fill to construct dam to elevation at least 1 foot above crown of outlet pipe. Install outlet pipe and compact clay soil around pipe. Install the perforated riser pipe, wrap with fabric, and surround with uniformly graded gravel. Install energy dissipation at downstream end of outlet pipe. Complete installation of dam to an elevation 10% above design height to allow for settling. Grade and stabilize spillway. Install monitoring post near outlet of basin. Mark maximum allowable sediment depth.

OPERATION AND MAINTENANCE PROCEDURES:

Inspect at least every week and after every ½" storm. Remove trash accumulation at outlet. Remove sediment accumulations once sediment reaches design depth, as indicated on monitoring posts. Repair and re-vegetate any erosion damage on spillway. Repair settlement, cracking, piping holes, or seepage at embankment. Replace gravel around riser if basin does not drain properly.

SITE CONDITIONS FOR REMOVAL:

Remove after upstream areas are stabilized. Regrade as appropriate and vegetate immediately.



STANDARD DRAWING: SC-6

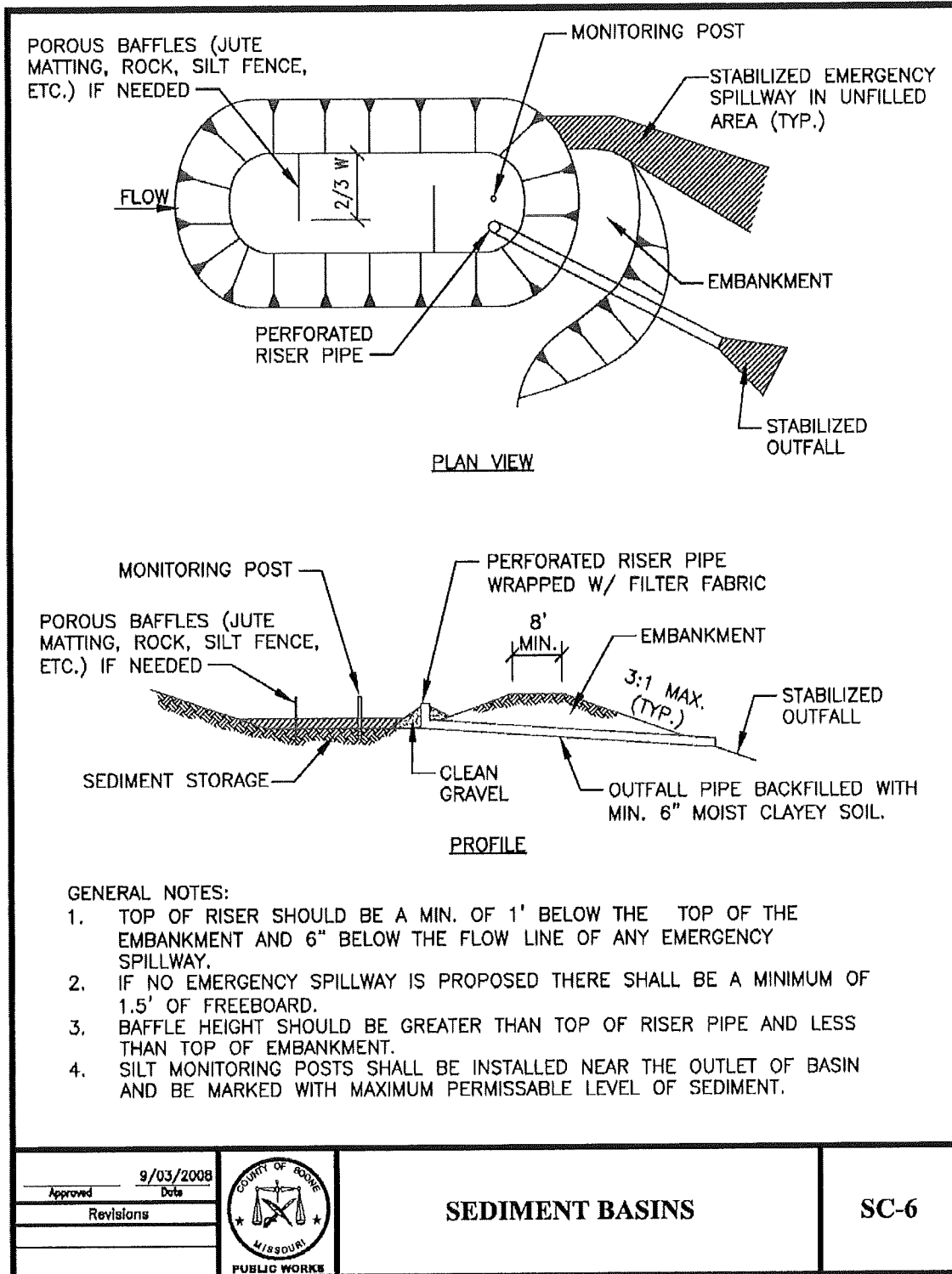



SC-7 SEDIMENT TRAP

A sediment trap is a temporary containment area that allows sediment in collected storm water to settle out during infiltration or before the runoff is discharged.

APPROPRIATE APPLICATIONS:

Sediment traps are commonly used at the outlets of stormwater diversion structures, channels, slope drains, construction site entrances, vehicle wash areas, or other runoff conveyances.

CONDITIONS FOR EFFECTIVE USE:

Type of Flow: Sheet flow and concentrated flow.

Contributing Area: Maximum of 5 acres.

Trap Volume: Silt load of 1800 cf/acre.

WHEN BMP IS TO BE INSTALLED:

Install sediment traps prior to disturbance of natural vegetation.

STANDARDS AND SPECIFICATIONS:

Take care to situate sediment traps for easy access by maintenance crews. Excavate an area for the sediment trap, making sure the side slopes are no steeper than 2:1 and the embankment height no more than 5 feet from the original ground surface. Install dewatering pipe, if necessary. Place and compact fill to construct embankments and the spillway. To reduce flow rate from the trap, line the outlet with rip rap and gravel over the dewatering pipe, if necessary. The spillway weir for each temporary sediment trap should be at least 4 feet long for a 1-acre drainage area and increase by 2 feet for each additional drainage acre added, up to a maximum drainage area of 5 acres. Install monitoring posts in the trap which mark $\frac{1}{2}$ the design depth for sediment accumulation.

OPERATION AND MAINTENANCE PROCEDURES:

Inspect at least every week and after every $\frac{1}{2}$ " storm. Remove trash accumulation. Remove sediment accumulations once sediment reaches design depth, as indicated on monitoring posts. Repair and revegetate any erosion damage. Repair settlement, cracking, piping holes, or seepage at embankment.

SITE CONDITIONS FOR REMOVAL:

Remove after upstream areas are stabilized. Regrade as appropriate and vegetate immediately.

STANDARD DRAWING: SC-7a and SC-7b

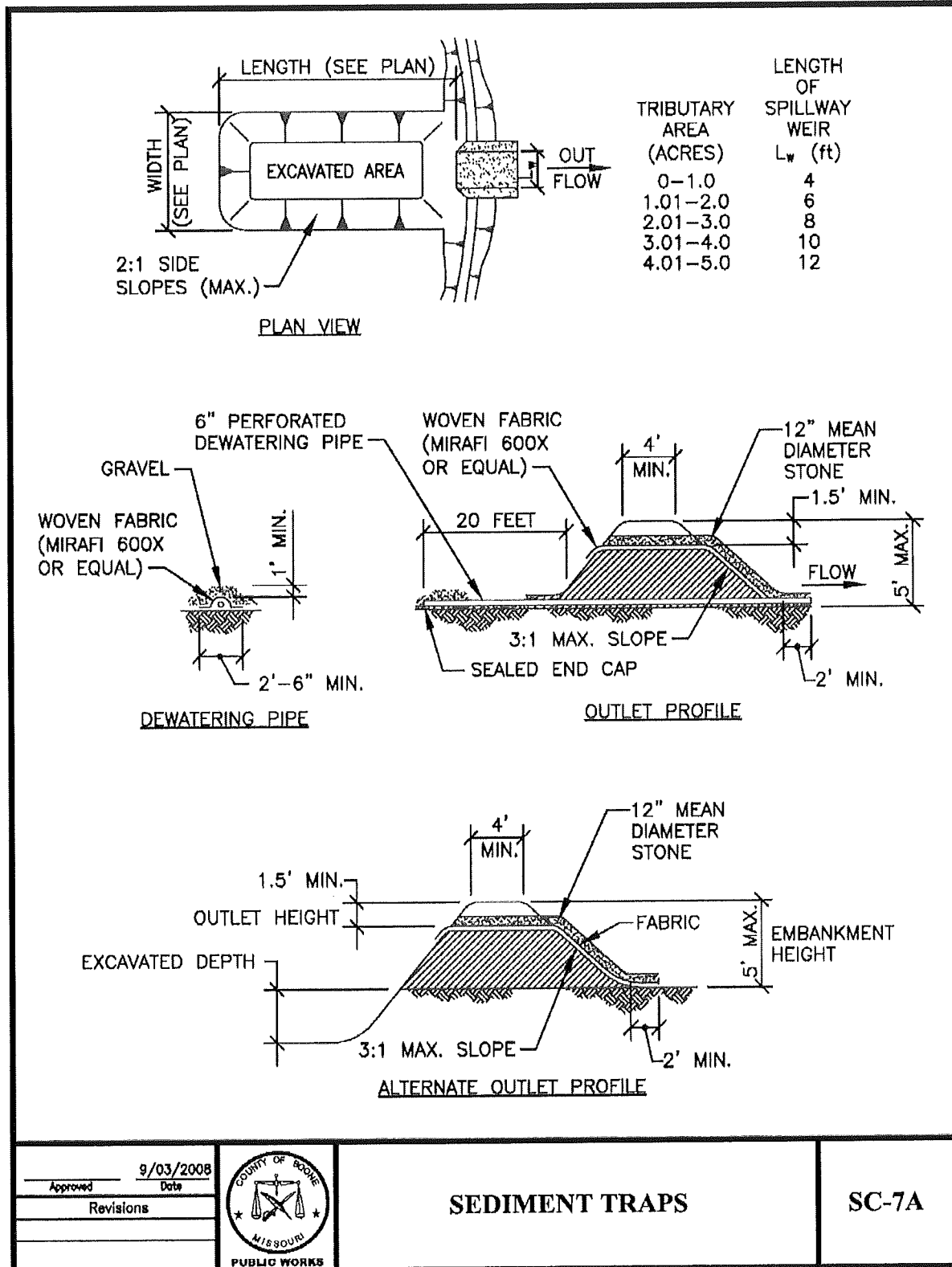

| | |
|-----------|-----------|
| Approved | 9/03/2008 |
| Date | |
| Revisions | |
| | |



SEDIMENT TRAPS

SC-7A



TEMPORARY SEDIMENT TRAP NOTES:

A) CONSTRUCTION SPECIFICATIONS:

1. THE AREA UNDER THE EMBANKMENT SHALL BE CLEARED, GRUBBED, AND STRIPPED OF ANY VEGETATION AND ROOT MAT.
2. FILL MATERIAL FOR THE EMBANKMENT SHALL BE FREE OF ROOTS OR OTHER WOODY VEGETATION, ORGANIC MATERIAL, LARGE STONES, AND OTHER OBJECTIONABLE MATERIAL. THE EMBANKMENT SHOULD BE COMPACTED IN 6-INCH LAYERS BY TRAVERSING WITH CONSTRUCTION EQUIPMENT.
3. THE EARTHEN EMBANKMENT SHALL BE SEEDED WITH TEMPORARY OR PERMANENT VEGETATION IMMEDIATELY AFTER INSTALLATION
4. CONSTRUCTION OPERATION SHALL BE CARRIED OUT TO MINIMIZE EROSION AND WATER POLLUTION.
5. ALL CUT AND FILL SLOPES SHALL BE 2H:1V OR FLATTER EXCEPT FOR EXCAVATED, WET STORAGE AREAS WHICH MAY BE AT A MAXIMUM 1H:1V GRADE.

B) INSPECTION AND MAINTENANCE

1. INSPECT THE TEMPORARY SEDIMENT TRAP WEEKLY AND AFTER EACH STORM EVENT OF 1/2-INCH OR GREATER.
2. REMOVE AND PROPERLY DISPOSE OF SEDIMENT WHEN IT ACCUMULATES TO ONE-HALF THE DESIGN VOLUME.
3. PERIODICALLY CHECK THE EMBANKMENT, SPILLWAY, AND OUTLET APRON FOR EROSION DAMAGE, SETTLING SEEPAGE, OR SLUMPING ALONG THE TOE AND REPAIR IMMEDIATELY.
4. REPLACE THE SPILLWAY GRAVEL FACING IF IT BECOMES CLOGGED.
5. INSPECT VEGETATION AND RESEED IF NECESSARY.
6. REPLACE ANY DISPLACED RIPRAP SO THAT NO REPLACEMENT ROCK IS ABOVE THE DESIGN GRADE.
7. REMOVE THE TEMPORARY SEDIMENT TRAP AFTER THE DRAINAGE AREA HAS BEEN PERMANENTLY STABILIZED, INSPECTED, AND APPROVED. DO SO BY DRAINING ANY WATER, REMOVING THE SEDIMENT TO A DESIGNATED DISPOSAL AREA, AND GRADING THE SITE TO BLEND WITH THE SURROUNDING AREA; THEN STABILIZE.

| | | | |
|------------------|----------------------------------|--|--------------|
| <u>Approved</u> | 9/03/2008 <small>Date</small> |  SEDIMENT TRAPS | SC-7B |
| <u>Revisions</u> | | | |
| | | | |
| | | | |



SC-8 CURB AND GUTTER INLET PROTECTION

A temporary sediment control barrier consisting of a filter media, such as compost filter socks, gravel and mesh, sandbags, gravel bags, etc., around a curb and gutter inlet designed to prevent sediment from entering the storm sewer. Shallow temporary ponding may occur during and after rainfall events.

APPROPRIATE APPLICATIONS:

Place protection at inlets where runoff may contain sediment-laden water.

CONDITIONS FOR EFFECTIVE USE:

Type of Flow: Sheet flow and concentrated flow.

Contributing Area: Maximum of 1 acre.

WHEN BMP IS TO BE INSTALLED:

Install inlet protection immediately after installation of the inlet, or prior to land disturbing activities beginning on the contributing upstream area to the inlet.

STANDARDS AND SPECIFICATIONS:

Typical types of curb and gutter inlet protection include: fabricated inlet filters (follow manufacturer's instructions), compost filter sock (make sure that both ends of the sock are anchored accordingly), gravel and wire mesh (construct and anchor wood frame, fasten wire mesh and fabric to frame and place the gravel on top of the entire structure), sandbags and gravel bags (may be placed either as a j-hook on the upstream end of the inlet or as a full barrier, sometimes stacked 2 bags high, across the entire opening of the inlet). Incorporate an overflow bypass into the inlet protection structure in areas, such as heavy traffic streets, where excessive ponding of water around the inlet may become a safety issue. Sediment controls behind the curb will be necessary to prevent the discharge of sediment in these bypasses.

OPERATION AND MAINTENANCE PROCEDURES:

Inspect inlet protection of all media types weekly and after each ½" rainfall event to make sure they are functioning properly. Remove trash and debris. Remove sediment from the inlet protection when half of the protection structure height has been filled. Repair elements to original configuration as needed.

SITE CONDITIONS FOR REMOVAL:

Remove after contributing drainage areas have been adequately stabilized.

STANDARD DRAWING: SC-8

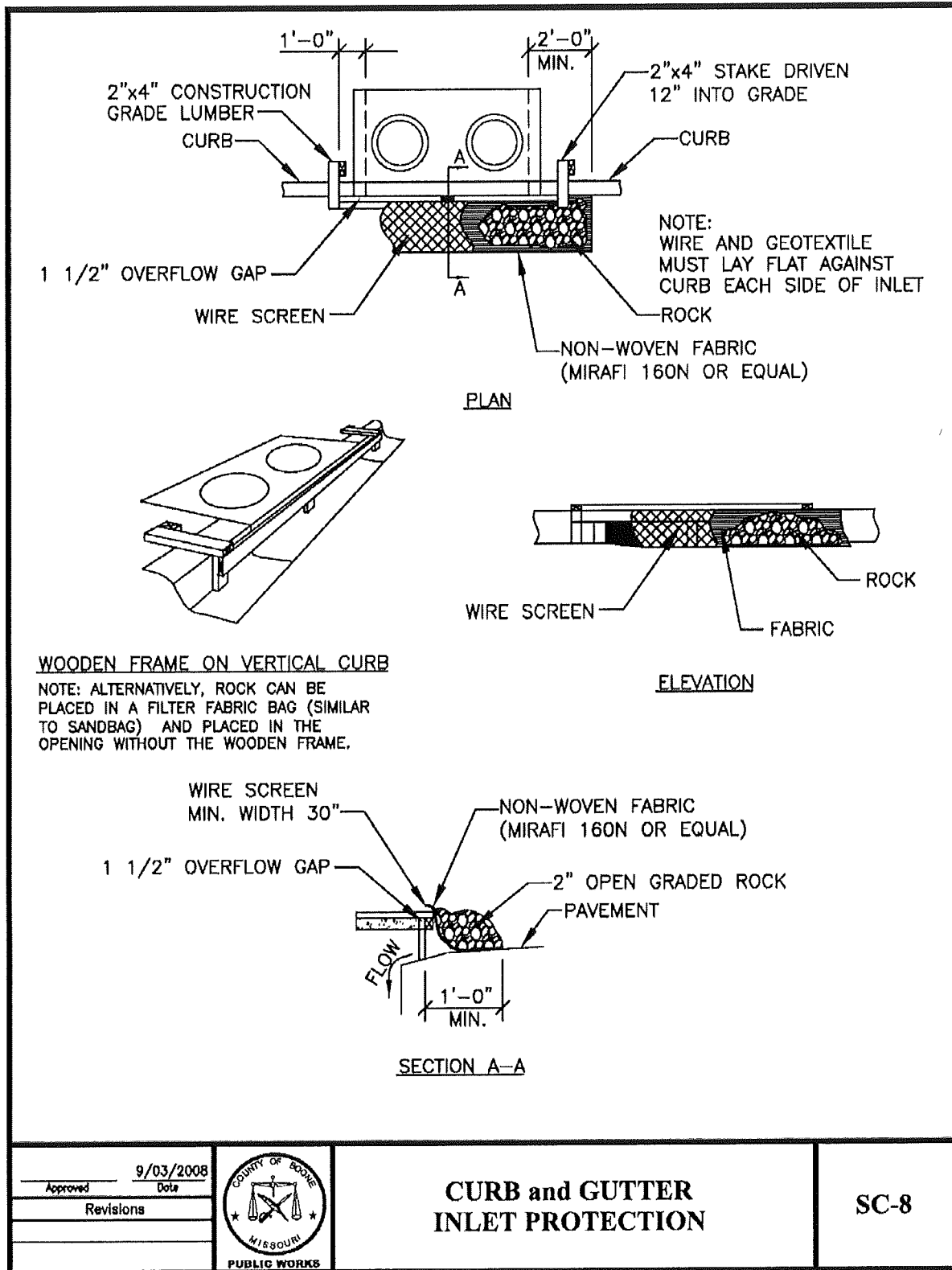



SC-9 DROP INLET PROTECTION

A temporary sediment control barrier consisting of a filter fabric around a recessed area inlet designed to prevent sediment from entering the storm sewer. Shallow temporary ponding may occur during and after rainfall events.

APPROPRIATE APPLICATIONS:

At recessed area or yard inlets where runoff may contain sediment-laden water.

CONDITIONS FOR EFFECTIVE USE:

Type of Flow: Sheet flow and concentrated flow.

Contributing Area: Maximum of 1 acre.

WHEN BMP IS TO BE INSTALLED:

Place inlet protection immediately after installation of the inlet, or prior to land disturbing activities beginning on the contributing upstream area to the inlet.

STANDARDS AND SPECIFICATIONS:

Typical types of drop inlet protection include: manufactured filtering product or silt fence frames. Follow the manufacture's instruction for placement of proprietary products. For the silt fence protection, install a wood frame, dig a trench around the inlet for fabric to be buried, fasten fabric tightly to frame, backfill and compact trench. Alternatively, a sod filter can be installed by preparing and fertilizing the soil around the inlet and installing sod for a distance of at least 4 feet in each direction. The sod should be staked, stapled and/or netted at the corners and center of sod strips as required and then watered immediately. For safety, inlet protection structures which pond water onto streets, parking lots or driveways should be designed to have some method for allowing excess water from large storms to bypass or overflow.

OPERATION AND MAINTENANCE PROCEDURES:

Inspect inlet protection of all media types weekly and after each significant rainfall event to make sure they are functioning properly. Remove trash and debris. Remove sediment from the inlet protection when half of the protection structure height has been filled. Repair elements to original configuration as needed.

SITE CONDITIONS FOR REMOVAL:

Remove after contributing drainage areas have been adequately stabilized.

STANDARD DRAWING: SC-9a and SC-9b

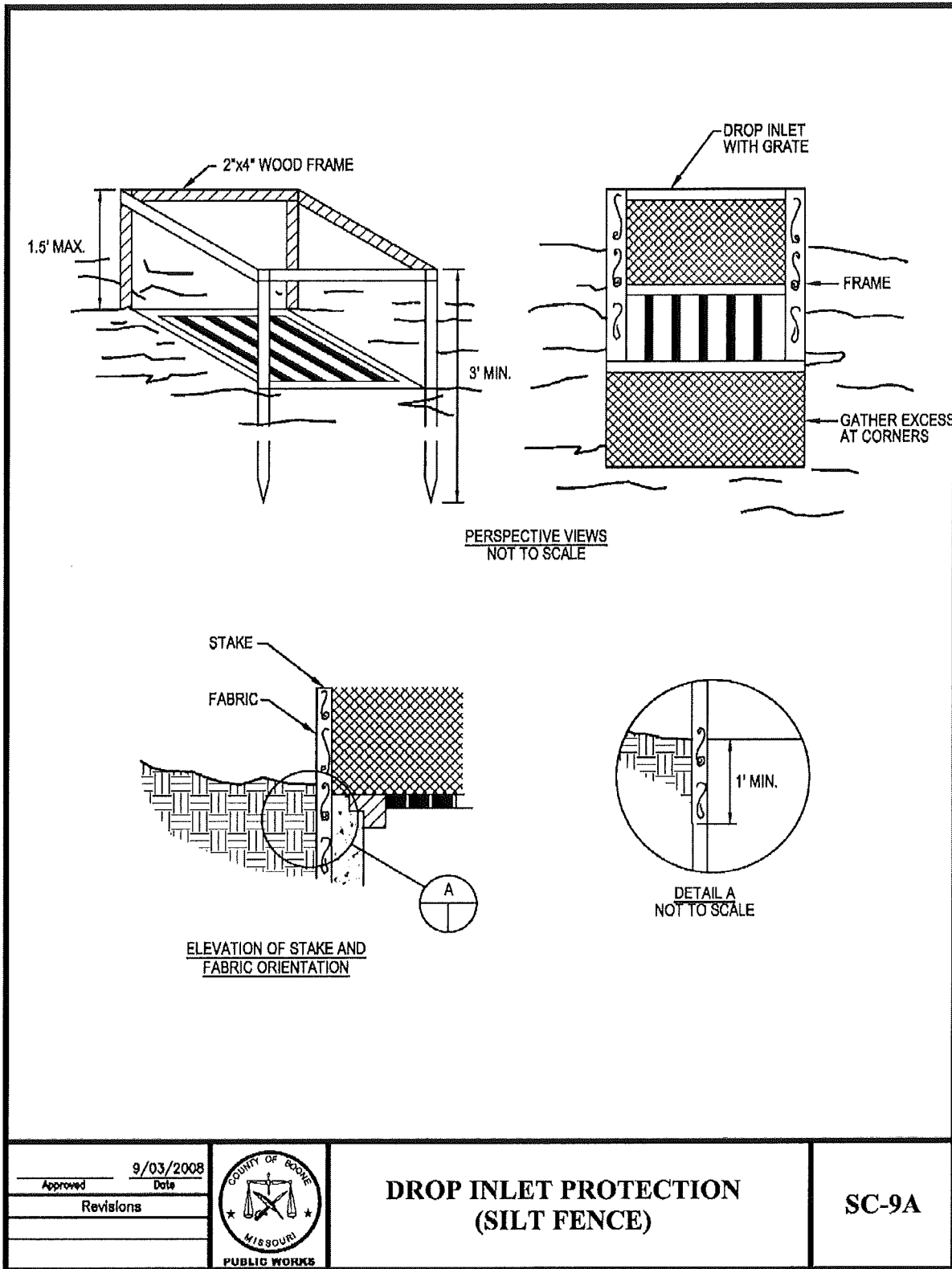

| | |
|-----------|-----------|
| Approved | 9/03/2008 |
| Date | |
| Revisions | |
| | |
| | |

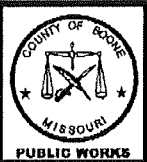

DROP INLET PROTECTION (SILT FENCE)

SC-9A



SEDIMENT FENCE DROP INLET PROTECTION NOTES:

A) CONSTRUCTION SPECIFICATIONS:

1. SEDIMENT FENCE SHALL BE CUT FROM A CONTINUOUS ROLL TO AVOID JOINTS.
2. FOR STAKES, USE 2X4 WOOD OR EQUIVALENT METAL WITH A MINIMUM LENGTH OF 3 FEET.
3. SPACE STAKES EVENLY AROUND THE PERIMETER OF THE INLET A MAXIMUM OF 3 FEET APART, AND SECURELY DRIVE THEM INTO THE GROUND, APPROXIMATELY 18 INCHES DEEP.
4. TO PROVIDE NEEDED STABILITY TO THE INSTALLATION, FRAME WITH 2X4 WOOD STRIPS AROUND THE CREST OF THE OVERFLOW AREA AT A MAXIMUM OF 1.5 FEET ABOVE THE DROP INLET CREST.
5. PLACE THE BOTTOM 12 INCHES OF THE FABRIC IN A TRENCH AND BACK FILL THE TRENCH WITH 12-INCHES OF COMPACTED SOIL.
6. FASTEN FABRIC SECURELY BY STAPLES, OR WIRE IT TO THE STAKES AND FRAME. JOINTS MUST BE OVERLAPPED TO THE NEXT STAKE.

B) INSPECTION AND MAINTENANCE:

1. THE STRUCTURE SHALL BE INSPECTED WEEKLY AND AFTER EACH RAIN EVENT OF 1/2 INCH OR GREATER AND REPAIRS MADE AS NEEDED.
2. SEDIMENT SHALL BE REMOVED AND THE TRAP RESTORED TO ITS ORIGINAL DIMENSIONS WHEN THE SEDIMENT HAS ACCUMULATED TO ONE HALF THE DESIGN DEPTH OF THE TRAP. REMOVED SEDIMENT SHALL BE DEPOSITED IN A SUITABLE AREA AND IN SUCH A MANNER THAT IT WILL NOT ERODE.
3. STRUCTURES SHALL BE REMOVED AND THE AREA STABILIZED WHEN THE REMAINING DRAINAGE AREA HAS BEEN PROPERLY STABILIZED.

| | | | | | | | | | | | | | |
|--|-----------|------|----------|--|-----------|--|--|--|--|--|---|--|---------------------|
| <table border="1" style="width: 100%;"> <tr> <td style="width: 80%; text-align: right;">9/03/2008</td> <td style="width: 20%; text-align: center;">Date</td> </tr> <tr> <td colspan="2" style="text-align: center;">Approved</td> </tr> <tr> <td colspan="2" style="text-align: center;">Revisions</td> </tr> <tr> <td colspan="2" style="text-align: center;"> </td> </tr> <tr> <td colspan="2" style="text-align: center;"> </td> </tr> </table> | 9/03/2008 | Date | Approved | | Revisions | | | | | |  | <p>DROP INLET PROTECTION (SILT FENCE) NOTES</p> | <p>SC-9B</p> |
| 9/03/2008 | Date | | | | | | | | | | | | |
| Approved | | | | | | | | | | | | | |
| Revisions | | | | | | | | | | | | | |
| | | | | | | | | | | | | | |
| | | | | | | | | | | | | | |



TC-1 CONSTRUCTION ENTRANCE/EXIT

A stabilized entrance to a construction site which is designed to minimize the amount of sediment tracked from the site on vehicles and equipment. Mud and sediment fall off of tires as they travel along the stabilized entrance.

APPROPRIATE APPLICATIONS:

At locations where it is safe for construction vehicles and equipment to access existing streets, preferably at the location of future streets or drives.

CONDITIONS FOR EFFECTIVE USE:

Site conditions will dictate design and need. Ditches or pipes, if needed, sized for 15 year, 20 minute storm; HGL 6" below surface of entrance.

WHEN BMP IS TO BE INSTALLED:

Install stabilized construction entrance/exit prior to vehicles or equipment accessing unpaved areas. This will most likely be the first BMP to be installed on the site.

STANDARDS AND SPECIFICATIONS:

Limit the points of entrance/exit to the construction site. Properly grade and compact each construction entrance/exit to prevent runoff from leaving the site. Install culvert under entrance if needed to maintain positive drainage. Place fabric and cover with aggregate, forming a diversion across the entrance, if needed, to direct runoff away from the roadway. Require all employees, subcontractors, and suppliers to utilize the stabilized construction access.

OPERATION AND MAINTENANCE PROCEDURES:

Inspect routinely for damage and assess effectiveness of the BMP. Remove sediment and clods of dirt from construction entrance continuously. Replace rock, as necessary, to maintain a clean surface for traffic. Repair any areas that have settled. Keep all temporary roadway ditches clear. Immediately remove any mud or debris tracked onto paved surfaces.

SITE CONDITIONS FOR REMOVAL:

Remove when vehicles and equipment will no longer require access to unpaved areas.

STANDARD DRAWING: TC-1

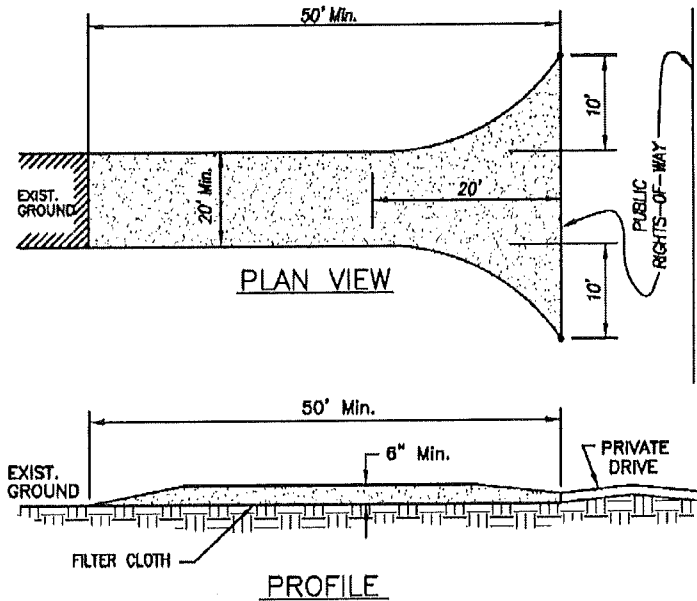

CONSTRUCTION SPECIFICATIONS

1. STONE SIZE - USE 2" STONE.
2. LENGTH - AS REQUIRED, BUT NOT LESS THAN 50 FEET.
3. THICKNESS - NOT LESS THAN SIX (6) INCHES.
4. WIDTH - TWENTY (20) FOOT MINIMUM, BUT NOT LESS THAN THE FULL WIDTH AT POINTS WHERE INGRESS OR EGRESS OCCURS.
5. FILTER CLOTH - WILL BE PLACED OVER THE ENTIRE AREA PRIOR TO PLACING OF STONE.
6. SURFACE WATER - ALL SURFACE WATER FLOWING OR DIVERTED TOWARD CONSTRUCTION ENTRANCES SHALL BE PIPED ACROSS THE ENTRANCE. IF PIPING IS IMPRACTICAL, A MOUNTABLE BERM WITH 3:1 SLOPES WILL BE PERMITTED.
7. MAINTENANCE - THE ENTRANCE SHALL BE MAINTAINED IN A CONDITION WHICH WILL PREVENT TRACKING OR FLOWING OF SEDIMENT ONTO PUBLIC RIGHTS-OF-WAY. THIS MAY REQUIRE PERIODIC TOP DRESSING WITH ADDITIONAL STONE AS CONDITIONS DEMAND AND REPAIR AND/OR CLEANOUT OF ANY MEASURES USED TO TRAP SEDIMENT. ALL SEDIMENT SPILLED, DROPPED, WASHED OR TRACKED ONTO PUBLIC RIGHTS-OF-WAY MUST BE REMOVED IMMEDIATELY.
8. PERIODIC INSPECTION AS NEEDED MAINTENANCE SHALL BE PROVIDED WEEKLY AND AFTER EACH RAIN EVENT GREATER THAN 1/2".

| | | | |
|--|--|--|--------------------|
| <p>Approved _____ Date 9/03/2008</p> <p>Revisions _____</p> | | <p>CONSTRUCTION ENTRANCE/EXIT</p> | <p>TC-1</p> |
|--|--|--|--------------------|



TC-2 WASHDOWN STATION

An area located at stabilized construction access points to remove sediment from tires and undercarriages, and to prevent sediment from being transported onto public roadways.

APPROPRIATE APPLICATIONS:

Tire washes may be used on construction sites where dirt and mud tracking onto public roads by construction vehicles may occur.

CONDITIONS FOR EFFECTIVE USE:

A downstream sediment trapping BMP is needed to treat dirty runoff from the washdown station. These stations require a supply of wash water and a turnout or doublewide exit to avoid having entering vehicles drive through the wash area.

WHEN BMP IS TO BE INSTALLED:

Washdown stations should be installed along with the stabilized construction entrance/exit, prior to vehicles or equipment accessing unpaved areas.

STANDARDS AND SPECIFICATIONS:

Grade and compact area for drainage under washdown pad. Install wash rack, which should be designed and constructed/manufactured for anticipated traffic loads. Provide a drainage ditch, grade that will convey the runoff from the wash area to a sediment trapping device. The drainage ditch should be of sufficient grade, width, and depth to carry the wash runoff. Install water supply and hose. Post signs in advance of the station indicating that all muddy vehicles and equipment must use the station prior to exiting the site.

OPERATION AND MAINTENANCE PROCEDURES:

Remove accumulated sediment in wash rack and/or sediment trap on a daily basis or as needed to maintain system performance. Repair any areas that have settled. Replace rock if necessary to maintain a clean surface.

SITE CONDITIONS FOR REMOVAL:

Remove when vehicles and equipment will no longer access unpaved areas.

STANDARD DRAWING: TC-2

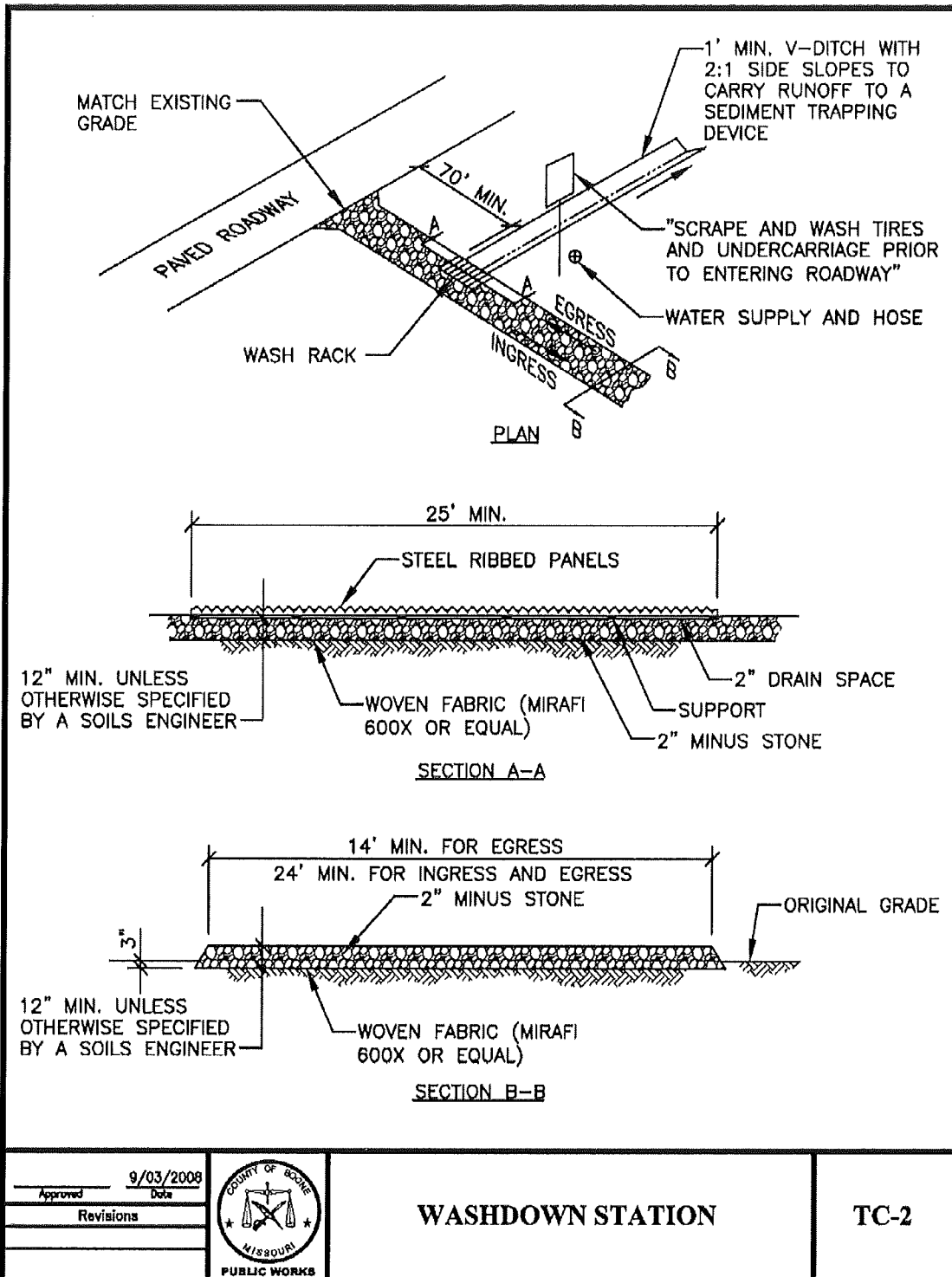



PP-1 NON-SEDIMENT POLLUTION CONTROL

These control measures are designed to prohibit chemicals, hazardous materials, solid waste, human waste and construction debris from polluting stormwater. Pollutants carried in solution or as surface films on runoff will be carried through most erosion control and sediment capture BMPs. Keeping substances like fuel, oil, asphalt, paint, solvents, fertilizer, soil additives, concrete wash water, solid waste, human waste and construction debris from polluting runoff can be accomplished to a large extent through good housekeeping on the site and following the manufacturer's recommendations for disposal.

APPROPRIATE APPLICATIONS:

Temporary sanitary facilities, collection, storage and fueling areas should be located onsite in an area that does not receive a substantial amount of runoff from upland areas and does not drain directly to lakes, creeks, streams, rivers, sewers, groundwater, wetlands, or road ditches.

CONDITIONS FOR EFFECTIVE USE:

An effective management system requires training and signage to promote proper storage, handling and disposal of materials, and follow up observations of actions and inspection of storage areas by management. Plans should contain notes clearly stating requirements for addressing potential pollutants.

WHEN BMP IS TO BE INSTALLED:

Pollution control practices should begin immediately and continue throughout the project.

STANDARDS AND SPECIFICATIONS:

Place waste receptacles near area of work. All fueling facilities present on the site shall adhere to applicable federal and state regulations concerning underground storage, above ground storage, and dispensers. Hazardous wastes shall be managed according to Missouri Hazardous Waste Laws and Regulations. Install appropriate signage. Post guidelines for proper handling, storage and disposal of materials, and emergency spill cleanup on site. Provide sufficient temporary toilet facilities to serve the number of workers on the site.

OPERATION AND MAINTENANCE PROCEDURES:

Inspect activities on a regular basis. Inspect storage areas and control devices at least every week and after every storm. Maintenance of temporary toilet facilities should be frequent and thorough. Make necessary corrections and repairs.

SITE CONDITIONS FOR REMOVAL:

Remove after contributing drainage areas have been adequately stabilized.

STANDARD NOTES:

General pollution notes:



1. Handling and disposal of hazardous materials:

DO: Prevent spills
Use up products completely
Follow label directions for disposal
Remove lids from empty bottles and cans when disposing in trash
Recycle wastes whenever possible

DON'T: Don't pour waste into sewers or waterways on the ground
Don't pour waste down the sink, floor drain or septic tanks
Don't bury chemicals or containers, or dispose of them with other waste
Don't burn chemicals or containers
Don't mix chemicals together

2. Containers shall be provided for collection of all waste material including construction debris, trash, petroleum products and any hazardous materials to be used onsite. All waste material shall be disposed of at facilities approved for that material.

3. No waste materials shall be buried on-site.

4. Mixing, pumping, transferring or otherwise handling construction chemicals such as fertilizer, lime, asphalt, concrete drying compounds, and all other potentially hazardous materials shall be performed in an area away from any watercourse, ditch or storm drain.

5. Equipment fueling and maintenance, oil changing, etc., shall be performed only in an area designated for that purpose. The designated area is equipped for recycling oil and catching spills.

6. Concrete wash water shall not be allowed to flow directly to storm sewers, streams, ditches, lakes, etc without being treated. A sump or pit shall be constructed to contain concrete wash water.

7. All paint, solvents, petroleum products and petroleum waste products, and storage containers (such as drums, cans, or cartons) shall be stored according to BMPs. The materials exposed to precipitation shall be stored in watertight, structurally sound, closed containers. All containers shall be inspected for leaks or spillage during the once per week inspection of BMPs. If substances such as oil, diesel fuel, hydraulic fluid, antifreeze, etc. are spilled, leaked, or released onto soil, the soil shall be dug up and properly disposed of. Spills on pavement shall be absorbed with sawdust, kitty litter or product designed for that purpose and disposed of at a licensed sanitary landfill. Hazardous or industrial wastes such as most solvents, gasoline, oil-based paints, and cement curing compounds require special handling. These materials will be removed from the site and recycled or disposed of in accordance with MoDNR requirements.

8. State law requires the party responsible for a petroleum product spill in excess of 50 gallons to report the spill to MoDNR (537-634-2436) as soon as practical after discovery.



Federal law requires the responsible party to report any release of oil if it reaches or threatens a sewer, lake, creek, stream, river, groundwater, wetland, or area, like a road ditch, that drains into one of the above.

9. Sufficient temporary toilet facilities to serve the number of workers on the site shall be provided. The facilities shall be serviced frequently to maintain a sanitary condition.